

# Electronics World

AUGUST, 1967  
60 CENTS

HOW TO SELECT MAGNETIC SOUND RECORDING TAPES

TROUBLESHOOTING INTEGRATED CIRCUITS—*Part 2. New Test-Equipment Techniques*

BIASING IN MAGNETIC TAPE RECORDING

CATV: PAST, PRESENT & FUTURE

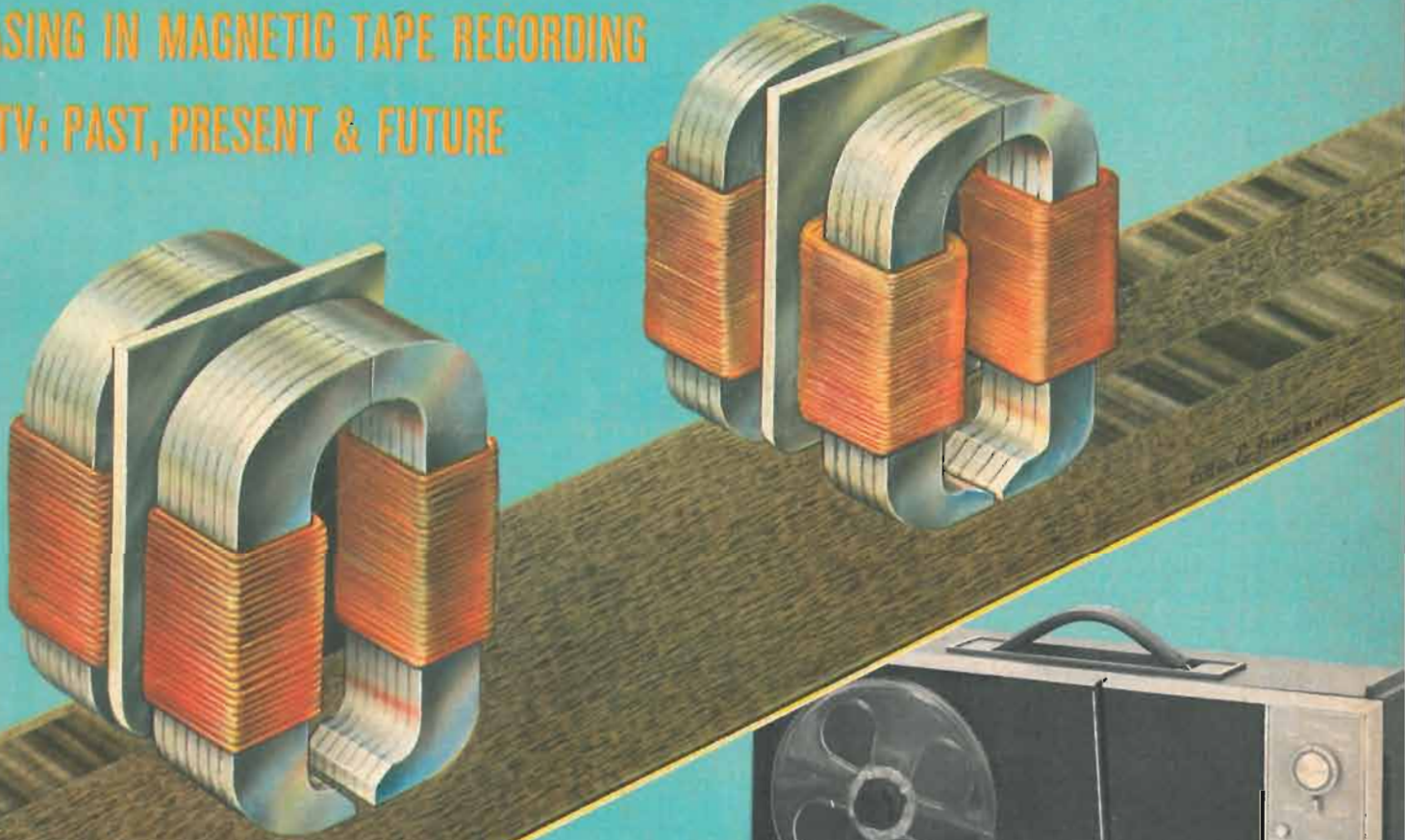

**AUDIO  
TAPE  
RECORDING**







# State-Of-The-Art Performance



**A** **NEW!** Heathkit IM-25 Solid-State High Impedance V-O-M . . . Never Before Has An Instrument With This Performance Been Available At Less Than \$200!



**NEW LOW PRICE SAVES \$30**

**D** **Now In Stock For Immediate Delivery!** Deluxe Heathkit "180" Color TV With Exclusive Built-In Servicing Features So YOU Can Maintain The Best Pictures At All Times!



**B** **NEW!** Amazing Receiver That's Winning Critic's Raves . . . Heathkit Solid-State 150-Watt AM/FM Stereo AR-15 With Space-Age Integrated Circuits!



**E** **Now In Stock For Immediate Delivery!** The World's Finest Color TV . . . Acclaimed By Experts And Owners Alike . . . Deluxe Heathkit "295" With The Industry's Biggest Picture!



**C** **NEW!** Deluxe Heathkit®/Thomas Transistor Theatre Organ At Up To \$500 Savings Over Factory-Built Version!

**F** **Solid-State** B & W TV Portable Kit. Plays Anywhere . . . 117 v. AC, 12 v. DC Or Battery Pack!



**G** **NEW!** 4-Speed Solid-State Stereo Portable Phonograph. Plays Anything From Bach To Rock . . . Ideal For Teenagers . . . Ideal For Den, Rec Room, Patio, Etc.

# In Money-Saving Kit Form

## A New! Heathkit Solid-State High Impedance V-O-M . . . Available Kit Or Wired

Performs all measurement jobs normally required in tube or transistor circuit development or service. Operates on built-in batteries or 120/240 v. AC., 50-60 Hz. Features 13 silicon transistor, 2 FET circuit; 11 megohm input impedance on DC, 10 megohm input impedance on AC; 9 DC voltage ranges from 150 mv full scale to 1500 v. full scale with  $\pm 3\%$  accuracy; 9 AC voltage ranges from 150 mv full scale to 1500 v. full scale with  $\pm 5\%$  accuracy; 7 resistance ranges, 10 ohms center scale x1, x10, x100, x1k, x10k, x100k, x1 meg . . . measures from one ohm to 1000 megohms; 11 current ranges from 15 uA full scale to 1.5A full scale; superior accuracy on current measurements . . .  $\pm 4\%$  on DC,  $\pm 5\%$  on AC; AC response to 100 kHz; 6", 200 uA meter with zero center scales for positive and negative voltage measurements without switching; 1% precision resistors; ten-turn thumbwheel zero adjustment for precision settings; new unitized construction and low profile appearance with beige and black color styling; easy circuit board assembly.

Kit IM-25, 11 lbs. . . . . \$80.00  
Assembled IMW-25, 11 lbs. . . . . \$115.00

## B World's Most Advanced Stereo Receiver . . . New Heathkit Solid-State 150-Watt AR-15

"Electronics World", May '67 issue, said: "Heath implies strongly that the AR-15 represents a new high in advanced performance and circuit concepts. After testing and living with the AR-15 for a while, we must concur."

Julian Hirsch, in the May '67 issue of IH-Fi/Stereo Review said: "In most respects, it is superior to any manufactured receiver we have tested, and in several respects its FM tuner outperforms any other we know of." "Several people have commented to us that for the price of the AR-15 kit, they could buy a very good manufactured receiver. So they could — but not one that would match the superb overall performance of the Heath AR-15."

Compare these features . . . two integrated circuits in the IF amplifier section for hard limiting, excellent stability and reliability . . . two crystal filters replace the usual transformers in the IF amplifier section resulting in an ideally shaped curve with no alignment or adjustment ever needed . . . FET FM tuner for freedom from cross modulation and excellent image rejection . . . AM as well as FM/FM stereo listening . . . all silicon transistor circuitry . . . overload and short circuit protection . . . two calibrated tuning meters . . . and much more.

Kit AR-15, (less cab.), 34 lbs. . . . . \$329.95  
AE-16, walnut cabinet, 10 lbs. . . . . \$19.95

## C Heathkit®/Thomas Transistor Theatre Organ . . . Full Professional Features At \$500 Savings

A rainbow of multi-colored stop tablets and luxurious horseshoe console combine with advanced transistor circuitry to make this new organ a truly outstanding instrument you'll be proud to have in your home. All parts are genuine Thomas factory-fabricated components. Features include 15 manual voices and 4 pedal voices . . . 19 voices in all . . . all at the flip of a tab; exclusive Thomas Color-Glo key lights so you can play complete songs the first time you try . . . even if you've never played an organ before; 200 watts peak power from two separate solid-state amplifiers; "stereo" sound; two separate speaker systems . . . 2-speed rotating Leslie, plus main system with two 12" speakers; two 44-note keyboards; 28 notes of electronic chimes; 13-note bass pedals; keyboard and pedal sustain, reverb; selective repeat and attack percussion; manual balance; timbre mellow; variable vibrato; pedal percussion and volume; expression pedal; stereo headset outlet; preassembled hardwood cabinet and bench with lustrous walnut finish. Optional Band Box automatically adds 10 percussion voices as you play . . . \$145.00

Kit TO-67, organ & bench, 265 lbs. . . . . \$995.00

## D & E Now Ready For Immediate Delivery . . . Heathkit Color TV's With Built-In Servicing Flexibility . . . New Low Price On GR-180 Saves \$30

Brilliant, crystal-clear pictures with "rare earth phosphors" for the industry's brightest, liveliest colors . . . clean, bold sound that will please the most discriminating ear . . . your choice of wall or cabinet installation . . . plus the ability to adjust the viewing quality of the picture to what you think is good to look at. That's what you get with a Heathkit Color TV. Here's what the experts say about these unique sets: Hubert Luckett, Popular Science Magazine: "— the circuitry, features and performance match or exceed those of sets selling at twice the price. Some of the features, such as the built-in servicing aids, can't be bought in ready-made sets at any price." High Fidelity Magazine: "The circuit design, to begin with, uses many advanced and "sophisticated" electronic techniques; the parts are of high quality and no scrimping or short-cuts have been taken in the chassis. The engineers at Heath, in fact, have leaned over to the side of the cautious so to speak, just to provide a wide margin for the varying ability of diverse kit-builders. The sound is distinctly better than what you hear from most TV sets . . . boasts a very up-to-date color convergence circuit which not only makes for sharply defined, lifelike color images, but

which permits the owner to initially adjust the set, and readjust it later if need be, without the use of instruments or test gear . . . the Heathkit set produces pictures that are as good as high-quality color film, or better."

D Kit GR-180, 180 sq. in. viewing area (less cabinet), 102 lbs. Was \$379.95, **Now Only \$349.95**  
Heath factory assembled contemporary walnut cabinet (shown) \$49.95. Early American cabinet \$75.00

E Kit GR-295, 295 sq. in. viewing area (less cabinet), 131 lbs. . . . . \$479.95  
Heath factory assembled contemporary cabinets \$62.95 (shown) and \$94.50. Early American cabinet \$99.95

## F Deluxe Heathkit 12" Diagonal B & W Transistor Portable TV

With the optional battery pack, you can take it fishing, camping, hunting, on a picnic, to the beach . . . anywhere you go. If you're a boat owner, run it off the boat's 12 v. battery. Or plug it into any 117 v. AC outlet for 82 channels of crisp, clean pictures. Features space-age integrated sound circuit, the size of a tiny transistor yet contains 39 parts . . . automatic gain control for steady, jitter-free pictures . . . front-panel mounted speaker . . . 3 video IF amplifiers with superior gain and controlled bandwidth . . . transformer regulated power supply . . . circuit breaker protection . . . preassembled & aligned VHF & UHF tuners . . . inputs for 300 ohm balanced and 75 ohm coax antennas . . . built-in telescopic whip plus 8" UHF loop antennas . . . handsome blue-gray plastic case with pearl mask. Easy to build in 12-15 hours.

Kit GR-104, 27 lbs. . . . . \$119.95

Kit GRA-104-1, rechargeable battery pack & outdoor sunshield, 9 lbs. . . . . \$39.95

## G New Low Cost Heathkit 4-Speed Transistor Stereo Portable Phonograph . . . Only \$49.95

Makes an ideal birthday or Christmas gift for any teenager . . . makes an ideal second system for the rec room, patio, any room in the house. Runs cool and collected with an 8-transistor amplifier that delivers up to 3 watts through two 4" x 6" speakers. Features volume, tone and stereo balance controls . . . completely assembled 4-speed stereo changer with separate record size and speed selectors . . . ceramic cartridge with dual Diamond/Sapphire styli for LP's or 78's . . . 45 rpm spindle adapter . . . preassembled pressed wood cabinet with handsome dark green and ivory polyethylene covering . . . plus carrying handle and fold-up changer compartment for suitcase portability. Assembles easily in 3-4 hours.

Kit GD-107, 24 lbs. . . . . \$49.95

ORDER NOW — USE THIS FORM —

**FREE!**

**WORLD'S LARGEST ELECTRONIC KIT CATALOG!**  
Describes these and over 250 kits for stereo, hi-fi, color TV, amateur radio, shortwave, test, CB, marine, educational, home and hobby. Save up to 50% by doing the easy assembly yourself. Mail coupon or write Heath Company, Benton Harbor, Michigan 49022

HEATH COMPANY, Dept. 15-8  
Benton Harbor, Michigan 49022

Enclosed is \$ \_\_\_\_\_, including shipping.

Please send model (s) \_\_\_\_\_

Please send FREE Heathkit Catalog.

Name \_\_\_\_\_

Address \_\_\_\_\_

City \_\_\_\_\_

State \_\_\_\_\_

Zip \_\_\_\_\_

Prices & specifications subject to change without notice.

CL-292





## Step up...Lead-in Loud and Clear with Belden

TV lead-in. Belden makes all kinds. Indoor, outdoor, for color and black and white reception. All have one thing in common: for price and performance you won't find better lead-in anywhere. They provide a picture-perfect link between antenna and set. Since no two installations are alike, Belden gives the right choice for every situation. But don't skimp on your lead-in. Step up... choose one that gets the most out of the cus-

tomers' overall investment. One that will delight the eye and ear with quality reception. For the absolute best, check out 8285 and 8290: the Color Twins. You won't find anything comparable for all-channel black and white as well as living color. Your Belden Distributor has all the facts. Talk to him today. Belden Corporation, P.O. Box 5070-A, Chicago, Illinois 60680.

\*Belden Trademark, and Belden U.S. Pat. 2,814,669



Shielded/Low Loss/All Channel—8290 (For color in congested areas)



All Channel/Low Loss—8285 (For color in uncongested fringe areas)



Celluline\*—8275



Weldohm®—8230





8225



Indoor—8226



Coax—8221

...the  missing  link  
in perfect  
picture reception

**Belden**

**BELDEN CORPORATION**  
P.O. Box 5070-A • Chicago, Ill. 60680

CIRCLE NO. 124 ON READER SERVICE CARD



THIS MONTH'S COVER ties in with special articles in this issue on audio tape recording. The center illustration is an artist's representation of a tape recording being made. The tape, with a single previously recorded mono track, is moving from left to right. It first passes under a dual quarter-track erase head which removes the prior recording. Then, the tape passes beneath a stereo quarter-track record/playback head which lays down the new stereo recording. Note the greater number of turns, the shorter gap, and the smaller width of the latter head. The tape equipment below includes, at the right, an Ampex 2100 Series reel-to-reel recorder (\$600); beneath it, a Norelco cartridge tape "Carry-Corder 150" (\$90); and to the left, Lear Jet "Stereo 8" Model AS-830-A automobile cartridge tape player (\$125) and Model HSA-900 home cartridge tape deck (\$80). Completing the picture is an Electro-Voice Model RE15 dynamic cardioid microphone (\$155).....Illustration: Otto Markevics.



**Publisher**  
**PHILLIP T. HEFFERNAN**  
**Editor**  
**WM. A. STOCKLIN**  
**Technical Editor**  
**MILTON S. SNITZER**  
**Associate Editor**  
**P. B. HOEFER**  
**Assistant Editor**  
**MARSHA JACOBS**  
**Contributing Editors**  
**WALTER H. BUCHSBAUM**  
**Prof. ARTHUR H. SEIDMAN**  
**Art Editor**  
**HERBERT L. SILBERMANN**  
**Art and Drafting Dept.**  
**J. A. GOLANEK**  
**Advertising Sales Manager**  
**LAWRENCE SPORN**  
**Advertising Service Manager**  
**ARDYS C. MORAN**

# Electronics World

AUGUST 1967

VOL. 78, No. 2

## CONTENTS

- 23** **CATV: Past, Present & Future** *Jerry E. Hastings*
- 27** **How to Select Magnetic Sound Recording Tapes** *Joseph Kempler*
- 32** **Recent Developments in Electronics**
- 34** **Biasing in Magnetic Tape Recording** *John G. McKnight*
- 37** **Troubleshooting Integrated Circuits** *Walter H. Buchsbaum & William D. Henn*  
**Part 2. New Test-Equipment Techniques**
- 41** **Value Engineering for the Electronics Industry** *Fred H. Posser*  
*Companies whose principal customer has been the U.S. Government are learning the philosophy of electronics firms in the commercial and consumer fields. Here is how they use an organized approach to reduce costs while maintaining quality.*
- 45** **Musical Instrument Sound Chart**
- 46** **Digital Computer Logic: What the Symbols Mean** *Ed Bukstein*  
*TTL, DTL, RTL, DCTL, RCTL, and CML are abbreviations for digital computer logic circuits. What do these terms stand for and what do the circuits look like?*
- 48** **Universal Wiring for Automotive Ignition Systems** *Charles C. Morris*
- 49** **The Operational Amplifier: Circuits & Applications** *Donald E. Lancaster*  
*These wide-band, high-gain products, available in both modular and IC packages, have been used in military and industrial circuits. New price and size reductions have opened commercial and consumer markets. Here's what's available.*
- 56** **Versatile Transistor Tester** *M. J. Moss*
- 59** **Potentiometer Linearity & Power Dissipation** *D. L. Heiserman*
- 76** **Bias Compensation for Transistor Output Stages** *Patrick Halliday*
- 83** **Solid-State Flashers for Light Displays** *A. A. Adem*

- 
- 6** **For the Record (Editorial)**  
*Walkie-Talkies to Move to 49.9 MHz*
  - 16** **EW Lab Tested**  
*"Knight-Kit" KG-895 "Superba" Amplifier*  
*Empire 888 Phono Cartridge*
  - 64** **Miniature Dictation Recorders** *John Frye*
  - 74** **Test Equipment Product Report**  
*"Knight-Kit" Model KG-663 Regulated D.C. Power Supply*  
*Triplett Model 600 Transistorized V.O.M.*  
*Sencore MU-140 Tube Tester*

## MONTHLY FEATURES

- 4** **Coming Next Month**      **68** **Radio & TV News**
- 12** **Letters from Our Readers**      **80** **Book Reviews**
- 88** **New Products & Literature**



**If it moves,  
The Antenna Specialists  
have a great new CB antenna  
to help it communicate!**

*on land...*



New "Grip-Stick" magnetic mount sticks to its business at all legal speeds! VSWR less than 1.5/1.0, capacity-matched, 16' cable. Less than 27" long. No-mar vinyl underside. Model M-168.

*on water...*



New "Sea-Hook" half-wave-length marine antenna has exceptionally low radiation angle. No ground plate required! Spring-loaded fold-down feature. White cycloac base, chrome-plated brass parts. VSWR less than 1.5/1.0. Model ASM-23.



*in the air...*

New "Sky-Hook" fiberglas airborne CB antenna—low-profile design, wind-rated over 250 mph. Temp. range: minus 50°F/plus 200°F. VSWR 1.5/1.0 or better. Only 24" long—reduces static, gives ample ground clearance. Model M-149.

**the antenna specialists co.**  
Div. of Anzac Industries, Inc.  
12435 Euclid Ave., Cleveland, Ohio 44106

Whatever your need, you can trust the "Stripes of Quality"!

Export: 64-14 Woodside Ave.  
Woodside, N.Y., 11377

**CIRCLE NO. 125 ON READER SERVICE CARD**

# COMING NEXT MONTH

## MEASURING MISSILE EXPLOSIONS

Using thermocouples, calorimeters, radiometers, pressure gauges, microphones, and tape recorders, engineers at Cape Kennedy stand ready to measure and record a missile catastrophe. Armed with such knowledge, we should be able to prevent most future mishaps.

## AVALANCHE TRANSISTOR CIRCUITS

These special switching transistors—the result of improved fabricating techniques—can generate extremely fast pulses (with subnanosecond rise times) at high power outputs.

## TEMPERATURE-DEPTH MEASUREMENTS IN THE OCEAN

A description of the electronic instruments which are being used to make important oceanographic measurements. Included are various types of electronic bathythermographs, infrared and quartz thermometers, and thermographs.

## LOW-COST VIDEO TAPE RECORDERS

A new and completely revised directory of TV tape recorders for various uses.

The listing provides complete technical specs on several dozen such units.

## LOW-COST SEMICONDUCTORS FOR THE CONSUMER MARKET

The availability of new plastic-cased IC's, transistors, and diodes is now opening up vast new home and auto markets. Here is what is happening to the semiconductors involved in this revolution and a look into the future as to possible new applications.

## GUNN OSCILLATORS

A new type of microwave semiconductor that may one day replace present complex and expensive sources and create new consumer microwave communications and radar devices.

## ELECTRONICS FOR SPEECH AND HEARING THERAPY

Special techniques for detecting response to auditory stimuli, loop-type induction receivers, and unique neurological sound inducers are some of the many types of electronics being used to help the hearing-handicapped.

All these and many more interesting and informative articles will be yours in the September issue of **ELECTRONICS WORLD** . . . on sale August 17th.

## ZIFF-DAVIS PUBLISHING COMPANY

William B. Ziff  
Chairman of the Board (1946-1953)

William Ziff  
President

W. Bradford Briggs  
Executive Vice President

Hershel B. Sarbin  
Senior Vice President

Philip Sine  
Financial Vice President

Walter S. Mills, Jr.  
Vice President, Circulation

Stanley R. Greenfield  
Vice President, Marketing

Phillip T. Heffernan  
Vice President, Electronics Division

Frank Pomerantz  
Vice President, Creative Services

Arthur W. Butzow  
Vice President, Production

Edward D. Muhlfeld  
Vice President, Aviation Division

Irwin Robinson  
Vice President, Travel Division

Radio & TV News • Radio News • Radio-Electronic Engineering Trademarks Reg. U.S. Pat. Off.

**SUBSCRIPTION SERVICE:** All subscription correspondence should be addressed to Electronics World, Circulation Department, Portland Place, Boulder, Colorado 80302. Please allow at least six weeks for change of address. Include your old address, as well as new—enclosing if possible an address label from a recent issue.

**EDITORIAL CONTRIBUTIONS** must be accompanied by return postage and will be handled with reasonable care; however publisher assumes no responsibility for return or safety of art work, photographs, or manuscripts.

**ELECTRONICS WORLD** (August, 1967, Vol. 78, No. 2). Published monthly at 307 North Michigan Avenue, Chicago, Illinois 60601, by Ziff-Davis Publishing Company—also the publishers of Airline Management and Marketing, Boating, Business & Commercial Aviation, Car and Driver, Cycle, Flying, HiFi/Stereo Review, Modern Bride, Popular Aviation, Popular Electronics, Popular Photography, Skiing, Skiing Area News, and Skiing Trade News. (Travel Weekly is published by Robinson Publications, Inc., a subsidiary of Ziff-Davis Publishing Company.) One year subscription rate for U.S., U.S. Possessions, and Canada, \$6.00; all other countries, \$7.00. Second Class postage paid at Chicago, Illinois and at additional mailing offices. Authorized as second class mail by the Post Office Department, Ottawa, Canada and for payment of postage in cash.

Editorial and Executive Offices  
One Park Avenue  
New York, New York 10016 212 679-7200

NEW YORK OFFICE 212 679-7200  
James J. Sullivan  
Joseph E. Halloran

MIDWESTERN OFFICE  
307 North Michigan Avenue  
Chicago, Illinois 60601 312 726-0892  
Midwestern Advertising Manager, Royce Richard

WESTERN OFFICE  
9025 Wilshire Boulevard  
Beverly Hills, California 90211  
213 CRestview 4-0265; BRadshaw 2-1161  
Western Advertising Manager, Bud Dean

JAPAN  
James Yagi  
Ishikawa Mansion  
#4, Sakuragaoka  
Shibuya-ku, Tokyo  
462-2911-3

CIRCULATION OFFICE  
Portland Place, Boulder, Colorado 80302



Member  
Audit Bureau of  
Circulations

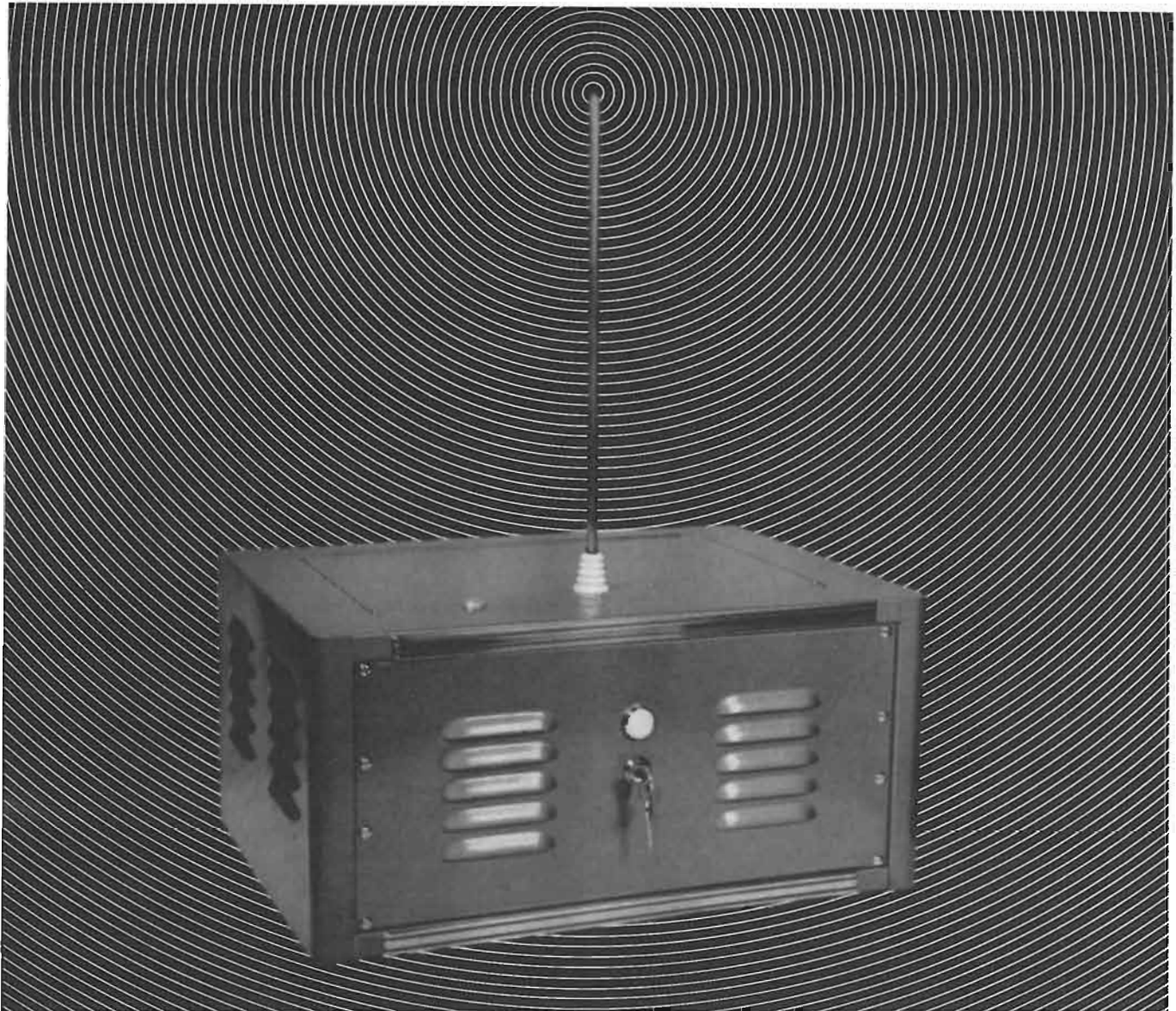

## You are now in Radar Sentry Alarm's r.f. microwave field. Don't move a muscle!

This security system is so sensitive, it can be adjusted to detect the motion of your arm turning this page.

And if this Portable Model Unit were within 35 feet of you and you moved... people up to a half-mile away could hear the siren. Plus with optional equipment, it can detect fire... turn on lights... even notify police.

What does a burglar alarm have to do with you?

Just this: Radar Sentry is no ordinary alarm. It is the most modern and effective security system available. And it's also electronic.

That's why we need you. We need Dealers with technical knowledge. For the most successful Dealers for Radar Sentry Alarm are men who know electronics. This is a product that sells itself when demonstrated properly.

It's been proven time after time. In fact, many of the more than one thousand readers of electronics magazines who became Dealers in the past year — sold a system on their *first* demonstration.

And that's why we need men with technical knowledge and experience.

Men like you.

### How about it?

Do you want to start a business of your own... or expand your present business with a product that in 8 years has become the world-wide leader in its field?

Do you want to earn up to \$5,000 a year in your spare time?

Do you want to earn \$20,000 and more full time? We'll show you how.

O.K., now you can move.

Fill out the coupon and get complete Dealer/Distributor information... free.

Mail to: RADAR DEVICES MANUFACTURING CORP.  
22003 Harper Ave., St. Clair Shores, Michigan 48080



Please tell me how I can have a business of my own distributing Radar Sentry Alarm Systems. I understand there is no obligation.

Name \_\_\_\_\_

Address \_\_\_\_\_

City \_\_\_\_\_ State & Code \_\_\_\_\_

EW-8



**Rx**  
**avoid**  
**headaches**



**use Sony Tape**

If you've been using any of the so-called bargain tapes, chances are you should have your heads examined. The odds are good that the heads are excessively worn and you're not getting the most out of your recorder. If you want to keep "factory-fresh" sound to your recorder—and avoid future "headaches" and keep it that way—Here's the prescription—buy Sony Professional-quality Recording Tape. Sony Tape is permanently lubricated by the exclusive Lubri-Cushion process. Sony's extra-heavy Ox-Coating won't shed or sliver and is applied so evenly that recordings made on Sony Tape are not subject to sound dropouts. Sony Tape captures and reproduces the strength and delicacy of every sound—over and over again. There's a bonus, too, with every 5" and 7" reel of Sony Tape—a pair of Sony-exclusive "Easy Threader" tabs to make tape threading the easiest ever. And Sony reels are a sturdier, heavier gauge plastic for protection against possible warping. It's just what the "Doctor" ordered and yours for just pennies more than "bargain" tape.

**SONY** **SUPERSCOPE**  
 SUN VALLEY, CALIFORNIA • 91352  
 CIRCLE NO. 99 ON READER SERVICE CARD



# For the record

WM. A. STOCKLIN, EDITOR

## Walkie-Talkies to Move to 49.9 MHz

**A**MID heated controversy within the electronics industry concerning the accuracy of certain publications which printed reports that the FCC was considering moving walkie-talkies off the 11-meter CB band has come a sudden and quite official confirmation by the Commission that this is indeed what it had in mind. In a late "Notice of Proposed Rule Making", the agency has formally admitted its intention of opening a new band at 49.9 MHz specifically for unlicensed 100-mW-type handheld transceivers.

In large part, the proposal closely follows the report on this page in the May issue (see "For the Record", page 6). The new docket would permit manufacturers a two-year grace period during which they could sell existing transceivers while re-tooling new ones for the v.h.f. band and all units in operation could continue in service for seven years before becoming illegal. The new 49.9-MHz band would also be available immediately upon enactment for those who wanted to get started early. Further, the proposal would allow for a power input of 100 mW "measured at the battery" instead of the 60-mW figure supplied us earlier.

What remains, however, is essentially a simple crystal-controlled transmitter and crystal-controlled receiver housed in a conventional walkie-talkie case with a self-contained antenna no longer than five feet in length. The units will be strictly regulated at the manufacturing point for emission attenuation either side of center frequency and will be checked to insure that no superregenerative receivers are slipped in. The transmitter/receiver will be capable of operating "on one of the following frequencies: 49.91, 49.93, 49.95, 49.97, and 49.99 MHz".

Although at this writing the docket is still a long way from final enactment, it is clear that the unlicensed walkie-talkies are in for a severe revamping based for the most part on the "chaotic interference" they appear to have wrought upon the already-troubled 27-MHz CB band. Coming closely on the heels of an earlier proposal calling for type-acceptance of licensed CB equipment, it is apparent that the new move is intended to bring the *whole* of the CB service into line with other forms of two-way radio—which must meet strict design requirements in order to be granted Commission acceptance.

It is also interesting to note that the Anti-Spectrum Pollution bill now pending before the House would also give the FCC the authority to "regulate the manufacture, import, shipment, sale, and use of any equipment which is capable of causing interference to radio communications." Earlier opposition by the Consumer Products Division of the EIA has been withdrawn, and there is no known opposition remain-

ing to prevent passage of this bill. In addition to reinforcing the Commission's powers to require type-acceptance of CB equipment such as walkie-talkies, it would also give the FCC absolute jurisdiction over everything from garage-door openers to electronic eavesdropping transmitters.

In the studied opinion of many informed Washington sources, all the legislation covered thus far seems to have an excellent chance of passage. Pressure by manufacturers and user groups against enactment of such rule changes has been non-existent. Thus far only Tokyo exporters of the 30-40 mW toy transceivers appeared ruffled by it all and even they failed to file a complaint.

From a slightly more objective vantage point, we can't help but feel a bit encouraged to see the FCC suddenly grappling with the CB situation after years of comparative indifference. Whatever means the Commission may be employing, it is clear that FCC Chairman Rosel H. Hyde intends to regain firm control of the CB sore spot—as well as a few others—as soon as possible, preferably with the backing of the affected manufacturing community.

While we may not agree 100% with every point in the Commission's proposals, it should be remembered that for the time being these are just proposals. Equitable consideration will be given to all comments before a final rule making is announced. Commissioner Cox, for example, has suggested that perhaps the power level on unlicensed 49.9-MHz transceivers could be raised to 1 watt and some of the more stringent requirements which may ultimately raise the price of the equipment to the consumer be relaxed somewhat so as not to price the units out of the market.

The Commission turnabout under Rosel Hyde appears to be: Yes, we *can* effectively regulate and promote intelligent growth of CB after all.

Late reports are that the agency budget has been increased for fiscal 1967, and undoubtedly a portion of this sum will be allocated to the understaffed Field Monitoring & Enforcement Bureau which is responsible for the task of keeping CB under control. Should this report be accurate and the allocation sizable, the new FCC "we can" attitude may work after all.

In a way it is exciting to contemplate any situation other than that which exists today on 27 MHz. Real progress in coping with flagrant on-the-air violations occurring almost by the minute coupled with the intense congestion and pile-ups presently found on these frequencies is impossible.

If the CB service could rid itself, by whatever means, of this congestion and illegal operations, it might attain a level of importance and practical value thus far undreamed of even by the electronics industry. ▲



Be the man who's always  
first to say: "I've got  
the answer right here!"



START USING THIS REMARKABLE

# ELECTRONICS SLIDE RULE

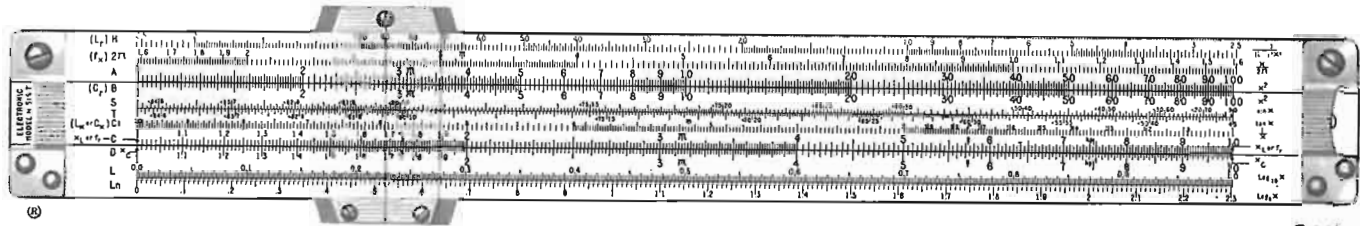

Front

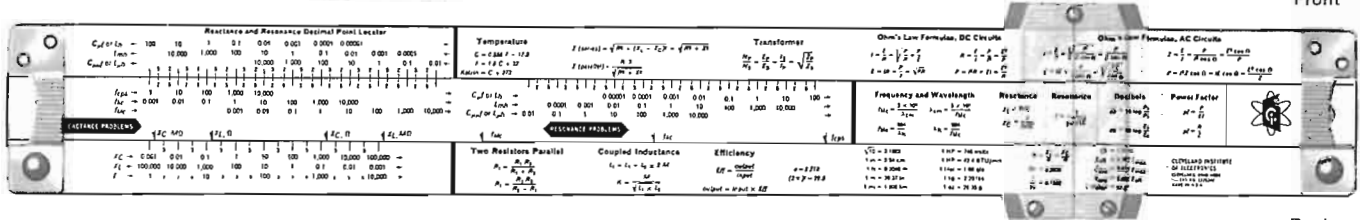

Back

SOME DAY EVERYONE in electronics may have a slide rule like this. Till then, the man who uses one will seem like a wizard as he solves reactance and resonance problems in 12 to 20 seconds—without pencil and paper.

This is a professional slide rule in every detail, a full 10" long, made exclusively for Cleveland Institute of Electronics, to our rigid specifications, by Pickett, Inc. It can be used for conventional computation as well as special electronics calculations. All-metal construction assures smooth operation regardless of climate.

Handsome top-grain leather carrying case has heavy-duty plastic liner to protect slide rule; removable belt loop for convenient carrying. "Quick-flip" cover makes it easy to get rule in and out of case.

You also get four full-length AUTO-PROGRAMMED™ Lessons, which teach you how to use the special electronics scales on the slide rule. These lessons have been carefully designed to meet the same high educational standards as the electronics career courses for which our school is famous. Even if you've never used a slide rule before, you'll soon whiz through the toughest problems with this CIE rule.

Deliberately underpriced. Many men in electronics have told us that this unique slide rule, leather case, and 4-lesson course easily add up to a \$50 value. But we have deliberately underpriced it at less than \$25. Why? Our reason is simple: we are looking for men in electronics who are ambitious to improve their skills...who know that this will require more training. If we can attract you with the low price of our slide rule and course—and impress you with its quality—you are more

likely to consider CIE when you decide you could use more electronics training.

Send for free booklet. See for yourself why this amazing slide rule and course have made such a big hit with busy electronics men everywhere. No obligation, of course—just an opportunity to get in on the best offer ever made to people in electronics. Just mail coupon, or write Cleveland Institute of Electronics, Dept. EW-142, 1776 East 17th St., Cleveland, Ohio 44114.

**CIE** Cleveland Institute of Electronics  
1776 East 17th Street, Cleveland, Ohio 44114

MAIL THIS COUPON FOR **FREE BOOKLET**

Cleveland Institute of Electronics  
1776 East 17th Street Cleveland, Ohio 44114  
Please send me without charge or obligation your booklet describing CIE Electronics Slide Rule and Instruction Course. ALSO FREE if I act at once: a handy pocket-size Electronics Data Guide.



Name \_\_\_\_\_ (please print)

Address \_\_\_\_\_

City \_\_\_\_\_ State \_\_\_\_\_ Zip \_\_\_\_\_



Accredited Member National Home Study Council  
A Leader in Electronics Training... Since 1934

EW-142



***Learning  
electronics  
at home***

***is faster,  
easier, more***

***interesting with new achievement kit***

Only NRI offers you this pioneering method of "3 Dimensional" home-study training in Electronics, TV-Radio . . . a remarkable teaching idea unlike anything you have ever encountered. Founded more than half a century ago—in the days of wireless—NRI pioneered the "learn-by-doing" method of home-study. Today, NRI is the oldest, largest home-study Electronics school. The NRI staff of more than 150 dedicated people has made course material entertaining and easy to grasp. NRI has simplified, organized and dramatized subject matter so that any ambitious man—regardless of his education—can effectively learn the Electronics course of his choice.

### **DISCOVER THE EXCITEMENT OF NRI TRAINING**

Whatever your reason for wanting knowledge of Electronics, you'll find the NRI "3 Dimensional" method makes learning exciting, fast. You build, test, experiment, explore. Investigate NRI training plans, find out about the NRI Achievement Kit. Fill in and mail the postage-free card. No salesman will call. NATIONAL RADIO INSTITUTE, Electronics Division, Washington, D. C. 20016

### **GET A FASTER START IN THE COURSE YOU CHOOSE WITH NRI'S REMARKABLE ACHIEVEMENT KIT**

When you enroll with NRI we deliver to your door everything you need to make a significant start in the Electronics field of your choice. This remarkable, new starter kit is worth many times the small down payment required to start your training. And it is only the start . . . only the first example of NRI's unique ability to apply 50 years of home-study experience to the challenges of this Electronics Age. Start your training this exciting, rewarding way. No other school has anything like it. What do you get? The NRI Achievement Kit includes: your first set of easy-to-understand "bite-size" texts; a rich, vinyl desk folder to hold your training material in orderly fashion; the valuable NRI Radio-TV Electronics Dictionary; important reference texts; classroom tools like pencils, a ball-point pen, an engineer's ruler; special printed sheets for your lesson answers—even a supply of pre-addressed envelopes and your first postage stamp.





## ELECTRONICS COMES ALIVE AS YOU LEARN BY DOING WITH CUSTOM TRAINING EQUIPMENT

Nothing is as effective as learning by doing. That's why NRI puts so much emphasis on equipment, and why NRI invites comparison with equipment offered by any other school, at any price. NRI pioneered and perfected the use of special training kits to aid learning at home. You get your hands on actual parts like resistors, capacitors, tubes, condensers, wire, transistors and diodes. You build, experiment, explore, discover. You start right out building your own professional vacuum tube voltmeter with which you learn to measure voltage and current. You learn how to mount and solder parts, how to read schematic diagrams. Then, you progress to other experimental equipment until you ultimately build a TV set, an actual transmitter or a functioning computer unit (depending on the course you select). It's the practical, easy way to learn at home—the priceless “third dimension” in NRI's exclusive Electronic TV-Radio training method.

## SIMPLIFIED, WELL-ILLUSTRATED “BITE-SIZE” LESSON TEXTS PROGRAM YOUR TRAINING

Lesson texts are a necessary part of training, but only a part. NRI's “bite-size” texts are as simplified, direct and well-illustrated as half a century of teaching experience can make them. The amount of material in each text, the length and design, is precisely right for home-study. NRI texts are programmed with NRI training kits to make things you read come alive. As you learn, you'll experience all the excitement of original discovery. Texts and equipment vary with the course. Choose from major training programs in TV-Radio Servicing, Industrial Electronics and Complete Communications. Or select one of seven special courses to meet specific needs. Check the courses of most interest to you on the postage-free card and mail it today for your free catalog.

Available Under  
**NEW  
GI BILL**

If you served since  
January 31, 1955, or  
are in service, check GI  
line in postage-free card.

## *custom training kits “bite-size” texts*

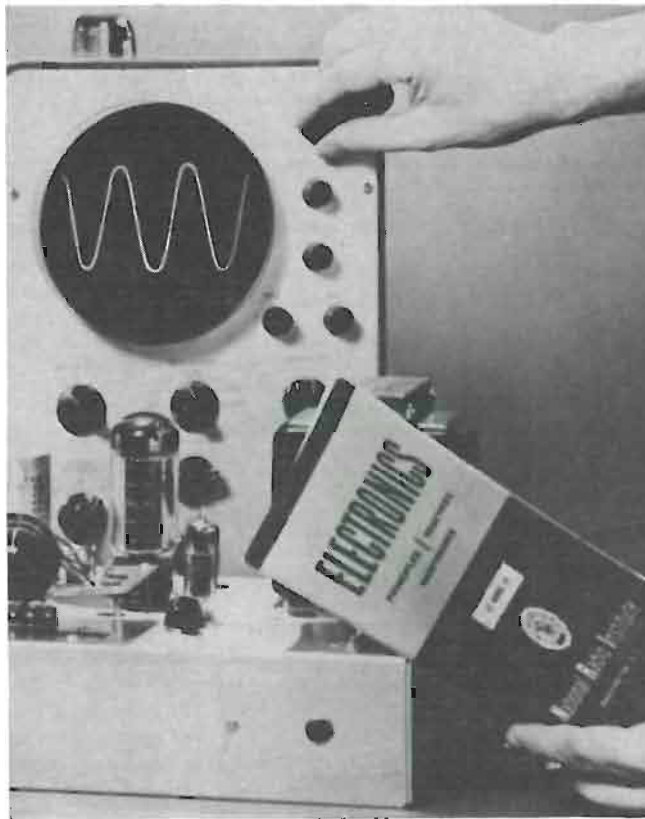
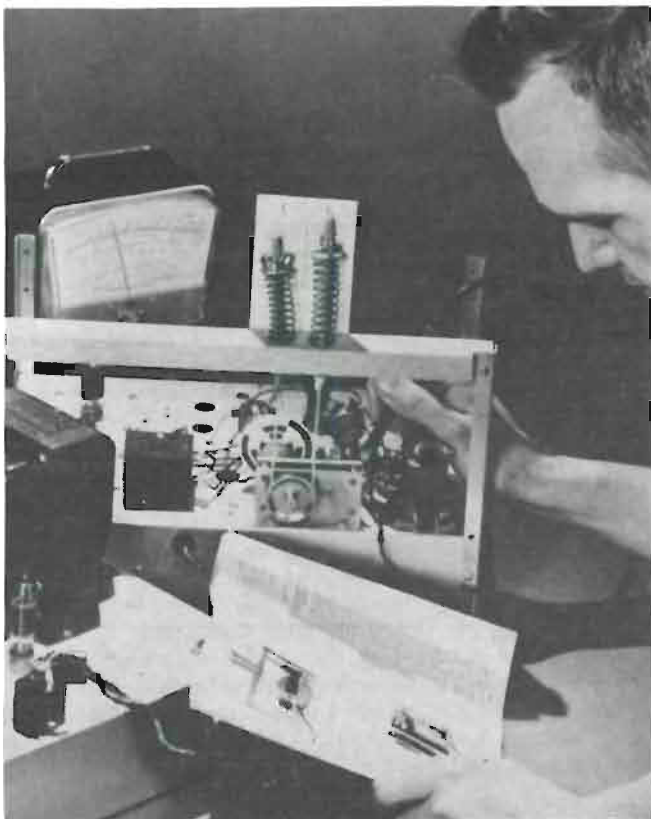



## CLOSEUP ON PROXIMITY EFFECT

PAUL K. FRANKLIN  
Chief Field Engineer

Most system designing for radio, television and sound reinforcement installations is based on stable response. Much effort is made to maintain operation at peak efficiency at all times so that results will be predictable.

Despite these precautions, disconcerting changes in response are sometimes noted without apparent cause. Careful examination of operating techniques by the performers may reveal the cause, one that is often difficult to control. This is the effect known as "proximity effect."

Proximity effect is the increase in bass response for close sounds compared to distant sounds. It is most noticeable at 2' or closer to most pressure gradient (directional) microphones, and does not occur with omnidirectional microphones.

This effect can have subtle, yet serious consequences for many systems. When a performer works "too close" bass energy sharply increases, sometimes as much as 10 db. This can serve to reduce intelligibility in radio systems since modulation levels are restricted by high energy lows having little useful information compared to high frequencies. It may also lead to excessive limiting in some systems, with the consequent destruction of natural aural perspective.

The unstable nature of microphone proximity effect problems can also destroy the carefully achieved effect of sound reinforcement systems, calling immediate attention to the existence of a sound system as performers move in and out of range near the microphone.

The severity of the proximity problem is directly related to the design characteristics of the microphone. Directional (pressure gradient) microphones having a single access port to the rear of the moving element generally suffer most from proximity effect, due to the close adjacency of the openings to the front and rear of the element. One of the beneficial by-products of the Electro-Voice Variable-D and Continuously Variable-D microphones has been the sharp reduction in proximity effect.

This is due to the relatively long distance from the front of the microphone to the rear access port for low frequencies. This greater distance equalizes driving force on the diaphragm for near and distant sounds (of equal intensity at the microphone) thus providing uniform response over a wider variation of performer-to-microphone distances. System performance is thus predictable over a wider range of circumstances.

For technical data on any E-V product, write:  
ELECTRO-VOICE, INC., Dept. 873N  
629 Cecil St., Buchanan, Michigan 49107

**Electro-Voice**  
SETTING NEW STANDARDS IN SOUND

CIRCLE NO. 118 ON READER SERVICE CARD  
12

## LETTERS FROM OUR READERS

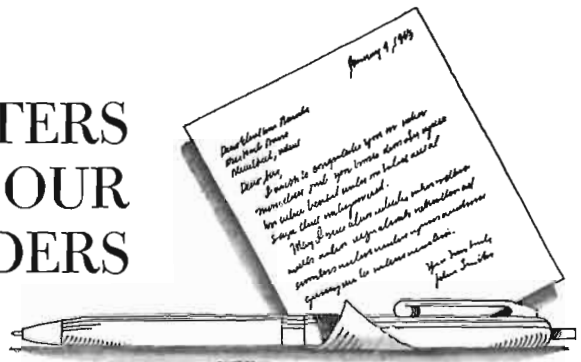

### ACOUSTIC SUSPENSION SPEAKERS To the Editors:

The Hirsch-Houck "EW Lab Tested" report in your June issue (p. 16) includes these general comments:

"Much of the suppressed 'bass' response of the big speaker systems that were prominent 10 or 15 years ago consisted of distortion products.

"The acoustic suspension speaker system . . . brought true bass to large numbers of listeners whose spatial or financial resources were limited."

These two statements, taken together, leave the disquieting impression that listeners with unlimited spatial and financial resources were at a disadvantage. I'm sure you don't mean that such listeners were expected to remain satisfied with the "distortion products" of the older designs, and reject the "true bass" of the acoustic suspension system, because the former speakers were bigger and more expensive.

When AR introduced the acoustic suspension speaker in 1954, we described it as an absolute advance in bass reproduction without respect to size or price. This view was confirmed by many, denied by some. Readers of EW may be interested in the following quote from Hirsch-Houck's own Audio League Report of 1955: "Speaker systems that will develop much less than 30% distortion at 30 cycles are few and far between. Our standard reference speaker system (using an AR-1W acoustic suspension woofer), the best we've ever seen, has about 5% distortion at 30 cycles."

EDGAR VILLCHUR, Pres.  
Acoustic Research, Inc.  
Cambridge, Mass.

*No, of course we didn't mean it that way.—Editors*

\* \* \*

### ELECTRONIC EAVESDROPPING To the Editors:

Your excursion into the dark area of electronic eavesdropping left me shaken. What is this great country coming to when anyone, for any malignant purpose whatsoever and having the price, can come into the possession of such privacy-invading devices?

Where are the protectors of our pri-

vacy? Sure, Senator Long is at the spearhead, but where are the others? Why are the sellers of these electronic snoops allowed to advertise their wares in reputable newspapers? Why do some electronic mail-order houses promote these noxious devices in their flyers? Has morality been overcome by greed for money to this extent?

Remember, it is only 17 years till 1984, so do all your "unspeaking" now.

CHARLES C. BRADY  
Seattle, Wash.

### To the Editors:

We were very unhappy to see ourselves considered suppliers of white-noise generators in your article on electronic surveillance equipment (May issue). We do not sell or manufacture such generators. It is our firm opinion that any type of white-noise generator cannot stop a transmitter from operating but can only jam receivers. Unless you are on a desert and can afford to jam everything around for miles, they cannot work. We do, however, distribute several items to combat wiretaps and surreptitious transmitters. These devices do not employ white noise, however.

BARRY LEVINE, Pres.  
Zelex Marketing Corp.

### NICKEL-CADMIUM BATTERIES To the Editors:

Nickel-cadmium batteries do have some peculiar properties. (See Bill White's letter on "Toothbrush Batteries" on p. 6 of your February issue.)

One puzzling phenomenon is an apparent loss of capacity. This deterioration of performance is typical when the cell is used repeatedly at only partial capacity. For example, if only 50 mA (milliamperes) of a 500-mAh cell are used up and the cell is then recharged, its memory registers that only 10% of its potential has been demanded, and, after just a few such occurrences, the cell becomes unable to yield power beyond this level.

Cells in this condition often can be restored by "deep discharge." For example, with a simple 500-mAh cell, try discharging it at 100 mA until it is completely exhausted, then short it out



# TENNESSEE NASHVILLE ELECTRONICS

One and one makes one  
whale of a company.



Take two electronics companies, each producing quality products for its own customers. Put them together, combining their experience and research, and you've got one whale of a source for electrolytic capacitors, potentiometers, resistors and other components.

Tennessee Electronics, Inc., and Nashville Electronics, Inc. have merged for greater production capacity and better quality control.

We call the new company Whale Electronics, Inc.

What's more, we now have an agreement with SIC-SAFCO of Paris for the production of highest quality, even more sophisticated components manufactured in the four production plants of this noted French firm. We also have access to and regular use of SIC-SAFCO's environmental test laboratories in Paris.

We also have a subsidiary in Hong Kong, producing components primarily for the home entertainment field.

Whatever your needs — whether you manufacture TV sets, computers or sophisticated guidance systems for space, you'll find the quality you want at the price you want at Whale Electronics.

Let us hear from you.

Whale Electronics, Inc., 2950 Foster Creighton Drive, Nashville, Tenn., Telephone 615 254-5576 • Telex 554 312

N  
NO CROSS TALK

C  
NO DOUBLE TALK  
NO DOUBLE TALK

R  
NO BACK TALK  
NO BACK TALK

S  
T  
A  
L  
K  
sonotone's  
new dynamic  
cardioid microphone  
for home recordings

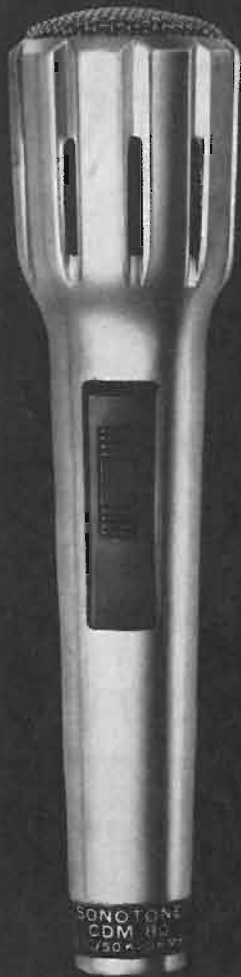

... eliminates distortion, background noises, boominess as no other tape microphone can.

Are unwanted sounds spoiling your home tape recordings? Has everyday household noise got you down? Sonotone has the unidirectional answer. It's our new CDM80 dual impedance microphone.

Just 5½ inches high and 1¼ inches in diameter at the top, this Sonotone microphone features the discriminating cardioid pattern that professional performers prefer. Captures every word, note and nuance directed into it, while suppressing extraneous, distracting noises, boominess and feedback. Yet it does not restrict your movements or introduce false tonal variations.

Complete with on-off switch, 15-foot cable and shield. Impedances of 200 ohms and 50K ohms.

Price: \$43.50



ELECTRONIC APPLICATIONS DIVISION  
SONOTONE CORPORATION • Elmsford, N.Y. 10523  
Exports: Singer Prods. Co., NYC. Cable: Exregnis, N.Y.

Write TODAY for Latest Catalog on Sonotone Microphones

CIRCLE NO. 100 ON READER SERVICE CARD

and leave it in the shorted condition for several hours.

In batteries, individual cells ought to be monitored for discharge voltage. When any cell is down to about 0.5 to 0.8 volt, it should be shorted, using a jumper wire. In time, it will be necessary to short every cell and leave each one for several hours. Eventual recharging—there is no hurry as these cells can remain discharged without damage—will probably restore performance. Sometimes this deep-discharge exercise has to be repeated.

A word of caution: discharging batteries without shorting the individual cells can cause "polarity reversal" of the cells. This is especially true with large cells such as the wet aircraft batteries.

Besides the memory phenomenon, you can expect other problems with nickel-cadmium batteries, such as dried-out electrolyte (even in sealed cells), defective ion separators, and partial internal shorts.

HARRY E. WOLF  
Electric & Design Engrg.  
United Air Lines  
San Francisco, Calif.

Several of our readers have also pointed out that one of the Eveready Battery engineering bulletins, in its discussion of nickel-cadmium batteries, mentions that if the cells have been stored for a long period, they should not be charged immediately but should first be fully discharged. The purpose of the discharging is to break down the oxide that forms on the cadmium electrode. During normal operation of the cell, oxygen must react directly with metallic cadmium.

As a result of the presence of cadmium oxide, there is an increase in the cell's internal resistance which reduces its output. Hence, periodic discharge is a good idea.—Editors

\* \* \*

#### FET VOLTMETER

To the Editors:

I found your article "FET Voltmeter" on p. 63 of the February, 1967 issue a very interesting one. In the second paragraph, the article states that the maximum voltage applied to the gate of the FET must be -0.5 volt. Then, in the third paragraph, the maximum voltage is given as -0.05 volt. Which is correct?

AVERY A. JOHNSON  
San Antonio, Texas

Although the voltmeter can be used to measure voltages as low as 0.05 volt, the maximum voltage that can be applied to the FET gate is 0.5 volt in any position of the range switch. We are sorry for the typographical error.—Editors



**EXTRA POWER**  
with  
**FINCO**  
**AMPLIFIERS**  
*For perfect color TV and  
FM Stereo Reception*

**FINCO MODEL #65-4**  
Antenna Amplifier  
\$47.95 list VHF-TV  
Two-transistor Antenna  
Amplifier for 75 OHM  
Downlead, and power  
supply with built-in  
single or dual 300 ohm  
outputs. Provides 12  
dB gain in the low band  
and 14 dB gain in the  
high band.



**FINCO MODEL #65-1**  
Distribution Amplifier  
\$29.95 list 2-tube 4-  
output VHF-TV or FM  
Distribution Amplifier  
for 300 OHM Opera-  
tion, providing 8 dB  
gain at each 300 ohm  
output to feed home or  
commercial systems.

**FINCO MODEL #65-5**  
Distribution Amplifier  
\$44.95 list VHF-TV 75  
OHM Single Outlet Dis-  
tribution Amplifier for  
deluxe home or com-  
mercial use to feed  
multiple sets through  
line tap offs or split-  
ters. Delivers 17 dB  
Low Band and 14 dB  
High Band.



**FINCO MODEL #65-2**  
Distribution Amplifier  
\$39.95 list 2-tube 4-  
output VHF-TV or FM  
Distribution Amplifier  
for 75 OHM CO-AX  
Operation, providing 6  
dB gain at each 75 ohm  
output to feed deluxe  
home or commercial  
systems.

**FINCO MODEL #65-6**  
Amplifiers \$79.95 list.  
VHF-TV Antenna Moun-  
ted two-transistor pre-  
amplifier with 75 OHM  
two-tube Single Output  
Distribution Post-am-  
plifier up to 30 dB gain  
for improved reception.  
Used in home or com-  
mercial installations to  
feed multiple sets.

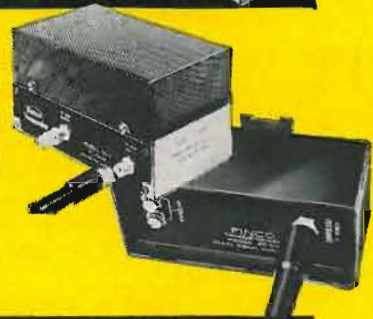

**FINCO MODEL #65-3**  
Antenna Amplifier  
\$44.95 list New VHF-  
TV Antenna Amplifier  
and Power Supply with  
built in single or dual  
outputs to improve re-  
ception of weak signals  
in fringe areas. Pro-  
vides 12 dB gain in the  
low band and 14 dB  
gain in the high band.

**FINCO MODEL #65-7**  
FM Signal Amplifier  
\$24.95 list. One-trans-  
istor Indoor Behind-  
the-set FM amplifier  
with a passive filter in-  
put circuit to reject sig-  
nals outside the FM  
band which cause in-  
terference. Delivers 20  
dB Gain.



**Sets "COME ALIVE" with  
Brilliant Sound and Color**  
A Finco high-gain, low-noise amplifier  
will bring in the sharpest **COLOR** or  
B & W TV picture and the finest sound!  
**All FINCO Products are Engineered  
For Color!**



Write for Color Brochure #20-411.  
**THE FINNEY COMPANY**

34 W. Interstate Street • Dept. 410 • Bedford, Ohio 44146

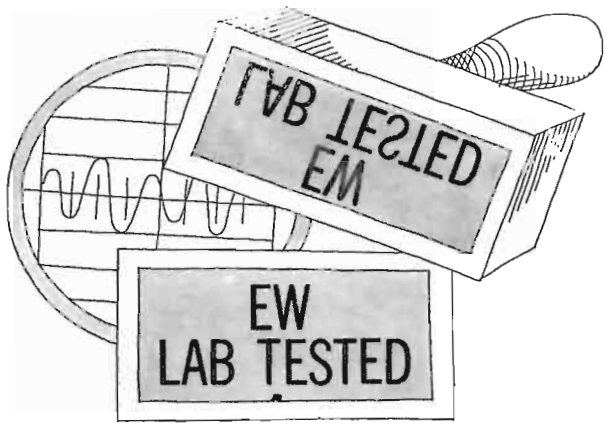

# HI-FI PRODUCT REPORT

TESTED BY HIRSCH-HOUCK LABS

**"Knight-Kit" KG-895 "Superba" Amplifier  
Empire 888 Phono Cartridge**

## "Knight-Kit" KG-895 "Superba" Amplifier

For copy of manufacturer's brochure, circle No. 29 on Reader Service Card.



THE "Knight-Kit" KG-895 solid-state stereo amplifier is offered as the finest amplifier in a comprehensive line of kits marketed by Allied Radio. The KG-895 is a powerful, fully flexible integrated stereo amplifier, rated at 120 watts total IHF music-power output. On a continuous basis it is rated at 40 watts per channel.

The amplifier employs modular design, with separate preamplifier, driver, and output stage modules. The preamplifiers are constructed on printed-circuit boards which plug into sockets on the chassis. They are fully enclosed in metal cases for shielding. The driver boards mount in cut-outs in the chassis and the output stages are on large finned heat radiators. The power supply is a simple, unregulated type with two full-wave silicon rectifiers operating from a single winding on the power transformer.

At the left of the panel are the less-

often-used controls—the balance control and the bass and treble tone controls. Tone controls for the two channels are concentric, with slip clutches allowing differential adjustment.

At the right side of the panel are the level control, the input selector, and the loudness-compensation switch. The unit has an unusual type of loudness compensation, which is independent of the level control setting. The loudness switch is marked "Flat, +5, +10, and +15". These numbers are not intended to bear any relation to the number of dB of compensation at any particular frequency. A fixed amount of high-frequency boost is added in all of the "on" positions of the control, amounting to about 10 dB at 10,000 Hz. In the "+5" position, a slight amount of boost is added below 50 Hz, reaching 5 dB at about 30 Hz. In the "+10" position, bass boost begins at about

300 Hz, reaching a maximum of 11.5 dB at 30 Hz. In the "+15" position, boost begins at about 600 Hz and reaches its maximum of 9 to 10 dB in the 20 to 100 Hz range.

A group of six colored lights in the center of the panel indicates the selected input ("Tuner", "Tape", two "Aux", "Phono", or "Tape Head"). The selector knob has no markings to indicate where it is set, but it rotates continuously in either direction so that one simply turns it until the desired light comes on.

A row of eight rocker switches along the bottom of the panel control infrequently used functions. These include a speaker "on-off" switch (for headphone listening via the front-panel jack), main or remote speaker selection, stereo mono, power, channel reversal, hi-cut and lo-cut filters, and tape monitoring. With the exception of the filter switches, all of these are normally in their upward positions.

Each input to the "Knight-Kit" KG-895 has its own level setting control, adjacent to the jack. This assures that the amplifier can handle signals of any level without danger of overload and distortion. All inputs, high-level as well as low-level, go to the preamplifier module, which has two stages of gain and an emitter-follower.

The high-level inputs are attenuated before the first preamplifier stage to prevent overdriving it. This allows the

(Continued on page 86)

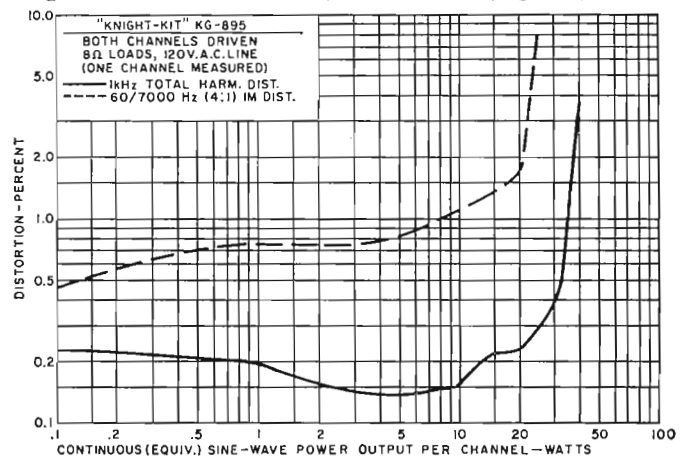
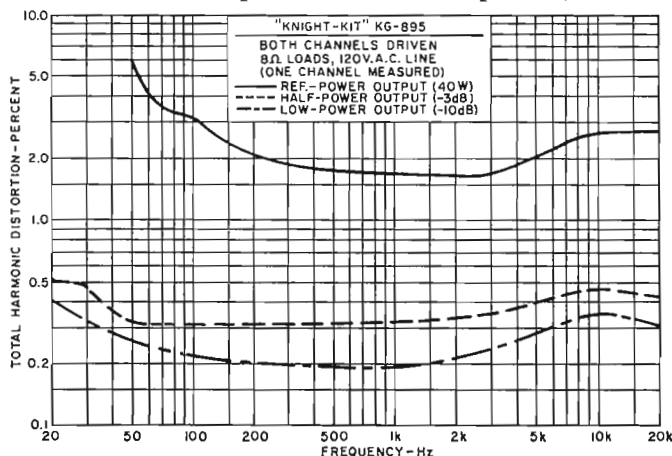



Zenith is honored  
to be the only TV manufacturer  
to win NATESA's  
"Friends of Service" award  
**five times!**



Zenith supports the aims and objectives of the National Alliance of Television and Electronics Service Association. So we are especially proud to receive the NATESA "Friends of Service" award for the *fifth straight year*.

Zenith is the only TV set manufacturer to be so honored five times by NATESA.

NATESA members for many years have played a vital role in providing expert electronics service and in training new men for dedicated service to the public.

We at Zenith pledge our continued support and cooperation in NATESA's great program.

**ZENITH**® *The quality goes in before the name goes on*

# You can earn more money if you get an FCC License

...and here's our famous CIE warranty that you will get your license if you study with us at home

**N**OT SATISFIED with your present income? The most practical thing you can do about it is "bone up" on your electronics, pass the FCC exam, and get your Government license.

The demand for licensed men is enormous. Ten years ago there were about 100,000 licensed communications stations, including those for police and fire departments, airlines, the merchant marine, pipelines, telephone companies, taxicabs, railroads, trucking firms, delivery services, and so on.

Today there are over a million such stations on the air, and the number is growing constantly. And according to Federal law, no one is permitted to operate or service such equipment without a Commercial FCC License or without being under the direct supervision of a licensed operator.

This has resulted in a gold mine of new business for licensed service technicians. A typical mobile radio service contract pays an average of about \$100 a month. It's possible for one trained technician to maintain eight to ten such mobile systems. Some men cover as many as fifteen systems, each with perhaps a dozen units.

## Coming Impact of UHF

This demand for licensed operators and service technicians will be boosted again in the next 5 years by the mushrooming of UHF television. To the 500 or so VHF television stations now in operation, several times that many UHF stations may be added by the licensing of UHF channels and the sale of 10 million all-channel sets per year.

## Opportunities in Plants

And there are other exciting opportunities in aerospace industries, electronics manufacturers, telephone companies, and plants operated by electronic automation. Inside industrial plants like these, it's the licensed technician who is always considered first for promotion and in-plant training programs. The reason is simple. Passing the Federal government's FCC exam and getting your license is widely accepted proof that you know the fundamentals of electronics.

So why doesn't everybody who "tinkers" with electronic components get an FCC License and start cleaning up?

The answer: it's not that simple. The government's licensing exam is tough. In fact, an average of two out of every three men who take the FCC exam fail.

There is one way, however, of being pretty certain that you will pass the FCC exam. And that is to take one of the FCC home study courses offered by the Cleveland Institute of Electronics.

CIE courses are so effective that better than 9 out of every 10 CIE-trained men who take the exam pass it...on their very first try! That's why we can afford to back our courses with the iron-clad Warranty shown on the facing page: you get your FCC License or your money back.

There's a reason for this remarkable record. From the beginning, CIE has specialized in electronics courses designed for home study. We have developed techniques that make learning at home easy, even if you've had trouble studying before.

## In a Class by Yourself

Your CIE instructor gives his undivided personal attention to the lessons and questions you send in. It's like being the only student in his "class." He not only grades your work, he analyzes it. Even your correct answers can reveal misunderstandings he will help you clear up. And he mails back his corrections and comments the same day he receives your assignment, so you can read his notations while everything is still fresh in your mind.

## It Really Works

Our files are crammed with success stories of men whose CIE training has gained them their FCC "tickets" and admission to a higher income bracket.

Mark Newland of Santa Maria, Calif., boosted his earnings by \$120 a month after getting his FCC License. He says: "Of 11 different correspondence courses I've taken, CIE's was the best prepared, most interesting, and easiest to understand."

Once he could show his FCC License, CIE graduate Calvin Smith of Salinas, California, landed the mobile phone job he'd been after for over a year.

## Mail Card for Two Free Books

Want to know more? The postpaid reply card bound-in here will bring you free copies of our school catalog describing opportunities in electronics, our teaching methods, and our courses, together with our special booklet, "How to Get a Commercial FCC License." If card has been removed, just send your name and address to us.

## THESE CIE MEN PASSED... NOW THEY HAVE GOOD JOBS

**Matt Stuczynski,**  
Senior Transmitter  
Operator, Radio  
Station WBOE



"I give Cleveland Institute credit for my First Class Commercial FCC License. Even though I had only six weeks of high school algebra, CIE's AUTO-PROGRAMMED™ lessons make electronics theory and fundamentals easy. I now have a good job in studio operation, transmitting, proof of performance, equipment servicing. Believe me, CIE lives up to its promises."

**Chuck Hawkins,**  
Chief Radio  
Technician, Division  
12, Ohio Dept.  
of Highways



"My CIE Course enabled me to pass both the 2nd and 1st Class License Exams on my first attempt...I had no prior electronics training either. I'm now in charge of Division Communications. We service 119 mobile units and six base stations. It's an interesting, challenging and rewarding job. And incidentally, I got it through CIE's Job Placement Service."

**Glenn Horning,**  
Local Equipment  
Supervisor, Western  
Reserve Telephone  
Company



"There's no doubt about it. I owe my 2nd Class FCC License to Cleveland Institute. Their FCC License Course really teaches you theory and fundamentals and is particularly strong on transistors, mobile radio, troubleshooting and math. Do I use this knowledge? You bet. We're installing more sophisticated electronic gear all the time; what I learned from CIE sure helps."

**ENROLL UNDER NEW G.I. BILL:** All CIE courses are available under the new G.I. Bill. If you served on active duty since January 31, 1955, OR are in service now, check box on reply card for G.I. Bill information.

**CIE** Cleveland Institute of Electronics  
1776 E. 17th St., Dept. EW-35, Cleveland, Ohio 44114

Accredited by the Accrediting Commission of the National Home Study Council, and the only home study school to provide complete coverage of electronics fundamentals plus such up-to-date applications as: Microminiaturization • Laser Theory and Application • Suppressed Carrier Modulation • Single Sideband Techniques • Logical Troubleshooting • Boolean Algebra • Pulse Theory • Timebase Generators...and many more.



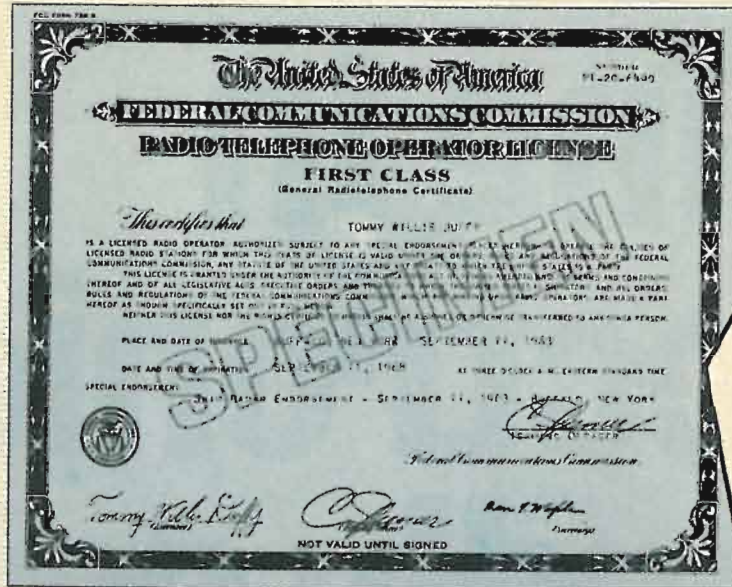

## Cleveland Institute of Electronics

# WARRANTY

## of success in obtaining a Government FCC License

The Cleveland Institute of Electronics hereby warrants that upon completion of the Electronics Technology, Broadcast Engineering, or First-Class FCC License course, you will be able to pass the FCC examination for a First Class Commercial Radio Telephone License (with Radar Endorsement);

OR upon completion of the Electronic Communications course you will be able to pass the FCC examination for a Second Class Commercial Radio Telephone License;

AND in the event that you are unable to pass the FCC test for the course you select, on the very first try, you will receive a FULL REFUND of all tuition payments.

This warranty is valid for the entire period of the completion time allowed for the course selected.

*G. O. Allen*

G. O. Allen  
President



# The hottest thing in electronics hardly gets hot at all

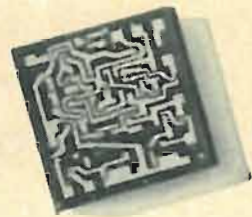

(RCA's solid integrated circuit, that is)

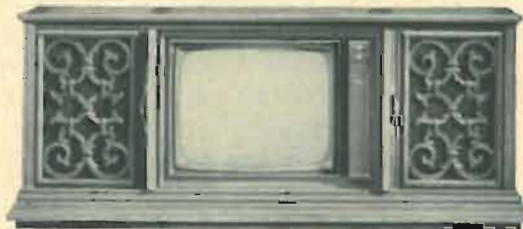

With the tiny chip there are few heat problems and low power consumption. And because integrated circuits run cooler, parts can be placed closer together to enhance design convenience. One day you may see stereo cabinets with more real storage space, and color TV sets the size of a transistor radio. At RCA Victor we've taken a

step into tomorrow by using integrated circuits now in new color and black and white TV and stereo phonographs. They're not only the most advanced products of their kind, they are more reliable than ever before.



The Most Trusted Name in Electronics

Trmk(s)®



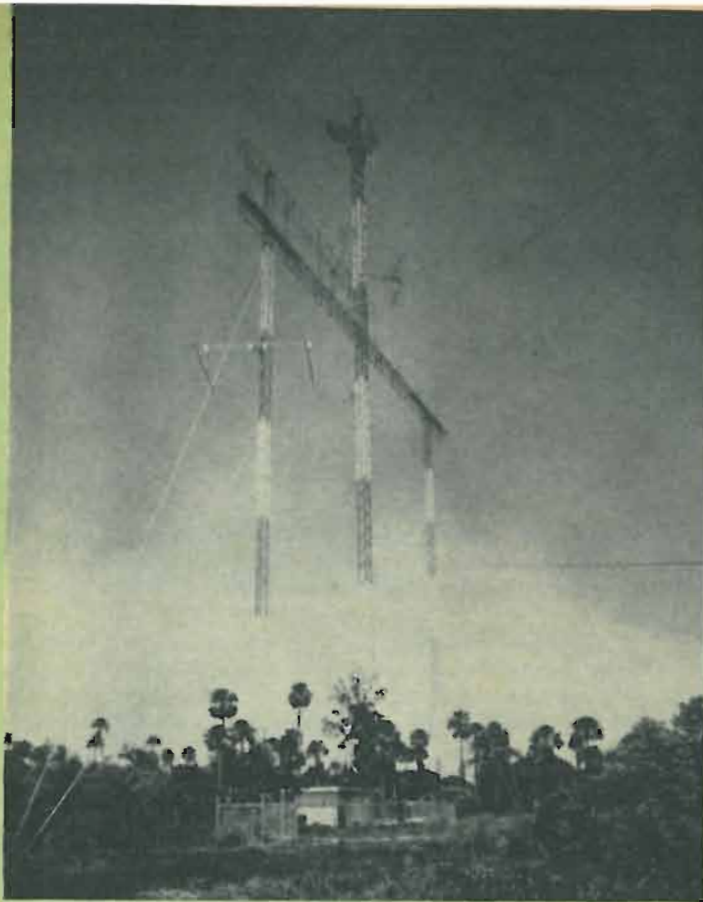

Tall antenna towers, such as this 240-foot installation at Ormond Beach, Florida, receive off-the-air TV broadcast signals which are then fed into miles of cable in a CATV system. Antennas on the towers pick up channels, 2, 4, 5, 6, 9, 12, and 24.

**A status report on community antenna television which, according to its proponents, will be able to deliver up to 20 TV channels into almost every home in the United States.**

By JERRY E. HASTINGS  
Manager, CATV Div., Jerrold Electronics Corp

# CATV: Past, Present & Future

**T**HE scene is some time in the not-too-distant future. Dinner over, you decide to look over the TV bill of fare for the evening. The offerings include a drama from New York, a ball game from Los Angeles, a musical revue from Chicago, a fashion show from Paris, and a news analysis from London. In addition, you have a choice of a local high school basketball game, an educational program originated at a local college, local shopping information, a speech by the mayor of your city, and a concert by the city orchestra.

Sound impossible? It is, with our present television system. But we have the technology right now to deliver up to 20 TV channels into almost every home in America. We could easily distribute, let us say, 10 network-type channels which would cover the entire United States through the use of relay satellites. While it is not possible at this time to launch a satellite with a transmitter powerful enough to be received on home antennas, the satellite relay broadcasts could be picked up by expensive sensitive antennas. These antennas could feed a CATV (community antenna television) system, which would carry the programs into your home by coaxial cable. And, the local public-service channels could easily be originated by the CATV system operators.

Perhaps, if we were starting from scratch, that is the kind of television system we would devise. But our television industry is like a city that has grown without planning, complete with narrow, twisted streets, snarled traffic, and dead ends.

At present, there are some 750 TV channels in the United States, occupying no less than 52 channels, each 6

MHz wide. Yet almost all of the time on all of these channels is occupied with the programming of only three networks. Only about 15% of total TV broadcast time is devoted to local programming.

CATV was originally conceived to fill the gap between supply and demand for television programming. To understand where CATV is now, and where it is going, let's take a look at the origins of this controversial industry.

## History of CATV

In 1946 there were only six television stations, serving some 8000 families. Within the next four years, however, television became a very important part of American life. Kids were rediscovering Hopalong Cassidy, Milton Berle was everybody's "Uncle Miltie", and we were regaled by such diverse fare as the Kefauver crime hearings and the Roller Derby.

By 1950, there were 100 television channels. Unfortunately, not everyone was able to get television reception. One such area was Lansford, Pa. Lansford was cut off from New York City and Philadelphia by high mountains. True, some lucky people who lived on hilltops outside of town did receive pretty good pictures—but only with very expensive towers and boosters.

Bob Tarlton, a Lansford retailer, was unhappy about the situation. Dealers elsewhere were doing a booming business in TV receivers and antennas, but sales in Lansford were practically zero. Glumly, Tarlton realized that because of the FCC freeze on new channels, it would be a long time—if ever—before TV came to Lansford.



## Milestones in CATV Legislation

- 1957 Group of broadcasters petition FCC to assume jurisdiction over CATV. Claim CATV is disrupting TV allocations and injuring broadcasters financially.
- 1958 FCC says it has no authority over CATV.
- 1960 United Artists brings suit against Fortnightly Corporation, West Virginia CATV operator, saying system carried U.A. programs without permission and reduced their sales value.
- 1962 Broadcasters claim possible loss of advertising revenue due to CATV.
- 1964 Dr. Franklin M. Fisher, in report made for National Association of Broadcasters, says that TV stations could lose revenue because of competition from CATV.
- 1965 FCC hires Dr. Martin Seiden, an economist, to study CATV. Seiden's report shows that TV broadcasting income has almost doubled since economic injury issue was first raised. Points out that 176 new TV channels have come on the air since 1959, 33 starting up in areas served by CATV systems. Also, about one-fourth of all TV station licensees are themselves CATV operators. Conclusion of the Seiden report: "CATV penetration has not been a direct cause of declining revenue," even for the 86 stations that reported declining revenue for 1963.
- 1965 FCC assumes jurisdiction over CATV systems (Apr.) using microwave relays of common carriers. At the same time, FCC splits decision over jurisdiction of non-microwave CATV systems and asks Congress for help in deciding issue.
- 1965 FCC decides 5 to 2 to allow one company to own (July) both TV broadcast station and CATV system. This opens way for even heavier influx of broadcasters into CATV.
- 1966 FCC reverses former stand and assumes jurisdiction (Feb.) over all CATV systems.
- 1966 U.S. District Judge William Herlands rules (May) against CATV in United Artists' copyright suit (see 1960).

The issues are still being debated, however, and Congress has yet to make a definitive ruling on CATV.

Then he had the brainstorm that launched the CATV industry. If the homes in the valley couldn't be taken to the mountaintop, perhaps the signals from the mountaintops could be taken by cable into the homes. Tarlton remembered hearing that apartment house owners were eliminating the jungle of antennas on their rooftops with a single master antenna. They charged their tenants a few dollars extra each month in order to hook up to the master antenna. Perhaps the same thing could be done with an entire community.

Tarlton took his idea to *Jerrold*, the Philadelphia-based firm which manufactured the equipment for the master TV antenna systems, and asked them if it could be used to solve the problem. Intrigued by the idea, *Jerrold* engineers built an antenna tower on one of the most favorable hills and ran coaxial cable along utility poles into town. Specially adapted master TV system equipment amplified the signals along the way, keeping them strong. Once in town it was an easy matter to distribute the signals into individual homes.

To pay for the system, Tarlton charged for hook-up to the system, plus a monthly fee. Almost immediately, there was a long waiting list of applicants for service and TV set sales soared.

Neighboring towns soon copied the idea and before long CATV systems were serving hundreds of cities and towns across the country. Thus, the community antenna business was well underway even before it had a name—and long before most people knew it existed.

In the early years of CATV, installation fees over \$100 were common. CATV operators felt that once the FCC freeze was lifted their systems would die.

They were wrong. Many communities today are still not served by television stations. Further, there are over 170 markets in the United States served by only one or two TV channels.

CATV operators began to find out that the more channels they gave their subscribers, the better their systems prospered. They found that they could move into one- and two-channel markets and still attract subscribers, provided they did two things: (1) lower the installation charge, and (2) offer a greater choice of programs and better picture quality.

Installation charges quickly fell to the \$25 to \$50 range. Early systems carried only three channels, but by the late 1950's most systems carried five channels. These five channels were all carried on the low v.h.f. band—channels 2 through 6. Where high-band channels (7 to 13) were picked up, they were converted to an unused low-band channel.

Thus, the highest frequency carried by most of these systems was 88 MHz. Of course, the higher the frequency, the greater the cable loss; therefore, amplifiers were spaced and set at levels to accommodate 88 MHz.

But the demand for channels grew, especially as CATV moved into larger communities, with more local TV service. In short order seven-channel systems, nine-channel systems, and twelve-channel systems became technically feasible and were put into commercial operation.

### Typical Case History

Before we leave the history of CATV, let's examine a case that is somewhat typical of CATV's past.

In 1953, David Coe was a 22-year-old engineering student at Cornell. His home town was Bainbridge, N.Y. Bain-

Inside the head-end building are signal processors for each channel.

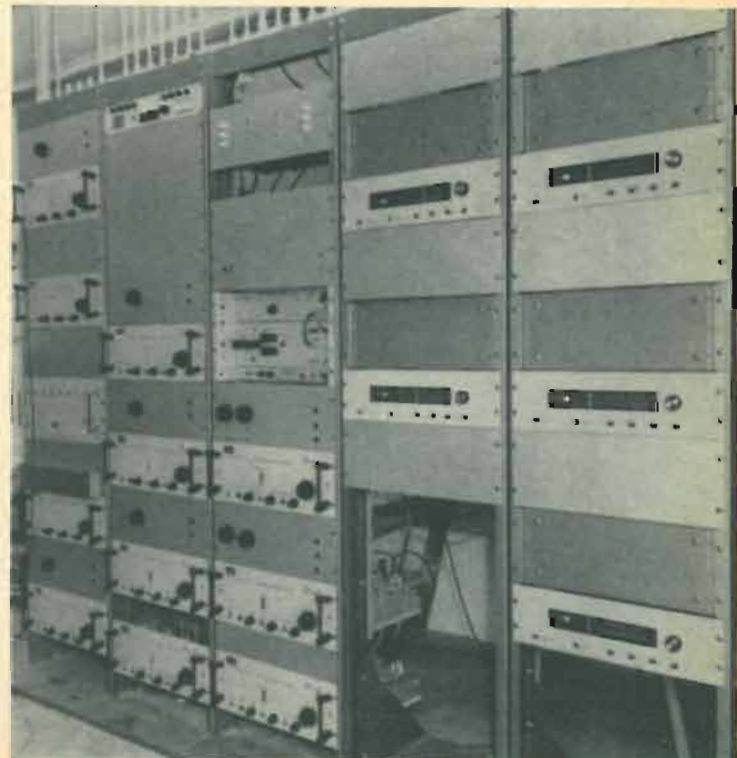



bridge was served by one TV station—channel 12 from Binghamton, which is 32 miles from Bainbridge. But many people in town couldn't even get channel 12. It was blocked by Mount Pleasant, which rose some 1600 feet behind David's home.

At Cornell, David Coe read some technical journals describing master TV systems and CATV systems.

Would such a system work in Bainbridge? He took the problem to his engineering advisers at Cornell. They saw no reasons why a master TV system wouldn't work for Bainbridge. And they gave David permission to build a system as a practical senior project, worth three semester hour credits toward his E.E. degree.

After one failure with a signal reflector atop Mount Pleasant, Coe built a system that worked. He mounted a high-gain antenna on the mountaintop and connected it into his home through 3500 feet of open wire, supported by trees and fences along the way.

Not only did he pull in channel 12, but he got good pictures from two Syracuse channels 60 miles from Bainbridge.

As news of the successful experiment spread, more and more of Coe's neighbors began to ask if they could be connected to his antenna. And the senior project became a business. Coe started by charging \$90 for connection to the system and \$2 per month.

By 1957, the system had added two new u.h.f. channels and boasted some 200 customers. But the system was still very unreliable and Coe was inundated with customer complaints. Coe decided, therefore, to convert from open-wire to coaxial cable and to run the cable along telephone company poles.

The system grew to 7 miles of cable and a plant with six line amplifiers. The subscriber list grew to 450 homes, which received not only the five TV channels, but six FM stations. And reception was improved significantly by a 100-foot tower with separate high-gain antennas for each channel.

## How a CATV System Works

Antennas, one or more per channel to be received, are placed on high towers. Weak channels are preamplified on all channels and sent down to signal processors in head-end "shack." Sound and picture carriers are carefully set to precise levels and all signals are mixed onto single cable. Because of new FCC non-duplication rules, many systems are presently being equipped with automatic switchers. Switchers can be programmed a week in advance to cut out the distant channel when it duplicates local-channel programming.

The output of the head end is sent into the subscriber area over a long trunk line, using trunk-line amplifiers along the way. Once in town, the signal is split by distribution amplifiers into feeder lines. If the feeder line is long, one or more line extender amplifiers are used.

Finally, the trunk line is "tapped" and a coaxial cable is taken into the customer's home. Each subscriber set requires a transformer to match the 75-ohm coaxial cable to its 300-ohm input.

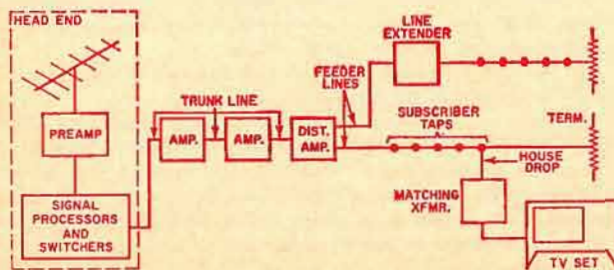
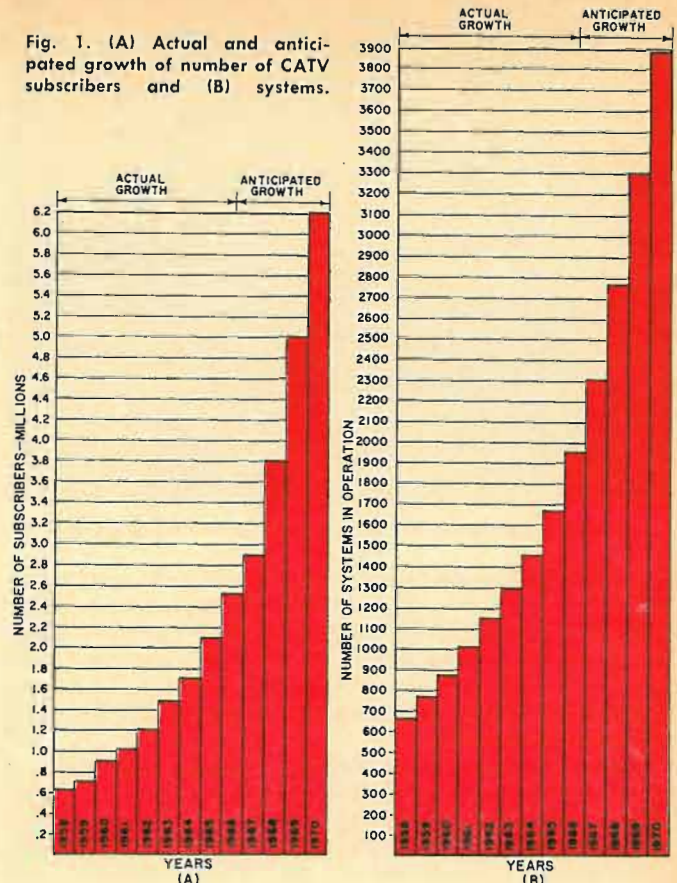

Fig. 1. (A) Actual and anticipated growth of number of CATV subscribers and (B) systems.



The subscriber installation charge is presently under \$50, and the service costs \$3.25 per month. It was raised from \$3.00 per month in 1962 when the telephone company increased its monthly pole rental charge from \$3 to \$4.50 per pole per year.

The Bainbridge system is typical of the small, early, family-type CATV system. Surely no one could argue with this fine example of American ingenuity and enterprise. But before long, CATV began to attract some big investors, and in recent years CATV has become the center of a storm of controversy which is still raging.

## CATV Today

Fig. 1 shows the growth of CATV in terms of subscribers and systems. Today, there are more than 1900 CATV systems in the United States, serving more than 8 million persons. Over 1500 applications for CATV permits have been granted and some 1800 are still pending.

CATV systems are scattered throughout the United States, including Alaska and Hawaii. The only state without an operating system is Connecticut, where CATV has become a political football. Pennsylvania, the birthplace of CATV, still has more than twice as many systems as California, its-closest competitor. Texas, New York, and Oregon also have a goodly number of CATV systems.

Systems range in size from only a handful of subscribers to 21,000 subscribers in Williamsport, Pa. In 1963, the median number of subscribers was only 850, but today this figure is over 1200.

Since CATV still serves only about 3% of the U.S. viewing audience, why all the controversy? What are television broadcasters and the FCC and Congress so excited about? The answer is the spectacular growth of CATV, as shown in Fig. 1. Some CATV industry experts have predicted that CATV will eventually serve up to 85% of all television homes! The infant industry born in the hills of Pennsylvania was threatening to grow into a giant.

People really began to worry about CATV when it was





Lineman installing tap-off connecting subscriber's home to cable.

proved viable in fairly large cities. For example, the Harrisburg, Pa. system, which went into operation in December 1965, has a potential of 50,000 subscribers. Further, there are no less than three franchises for portions of New York City, each with a two-year renewable contract. And franchises have already been granted in sections of Philadelphia and Los Angeles.

Under pressure from a number of groups, the FCC asserted jurisdiction over CATV systems in March of 1966. Here is a summary of the rules:

1. The FCC has jurisdiction over all CATV systems, except apartment-house systems and CATV systems with less than 50 subscribers.

2. Each CATV system must carry all local channels, "without material degradation". Local channels have been defined as channels that place a Grade B or better signal over the area served by the system. Even if the channel is available to the area only *via* translator, it must be carried. To date, there is no precise definition of what is meant by "without material degradation."

3. CATV systems may not bring in distant signals which duplicate the programs of local channels. Earlier FCC rules restricted microwave-served systems from duplication for a period of 15 days before and after the local station's telecast. Present rules, however, require only same-day non-duplication. Also, there is no non-duplication restriction if the local channel carries a program in monochrome and the distant channel carries it in color.

4. The FCC requires a full hearing on all applications in the top 100 TV markets. The object of these hearings is to be certain that no TV channels in the market will suffer economic harm. Systems in the top 100 markets may be forbidden to import distant channels. A "grandfather" clause exempts systems existing in the top 100 markets before February 15, 1966. However, even these systems are restricted from expanding without an FCC hearing.

The effect of these rules has been relatively small on systems outside of the top 100 markets. Most of these systems are already carrying local channels. A switcher of some kind can be used to meet the non-duplication requirement. The new FCC rules, however, impose what is essentially a "freeze" on the top 100 markets.

### The Copyright Issue

CATV has also been attacked on another front. Is it legal to pick up a program and deliver it to subscribers without any payment to the originator? Until now, CATV operators have believed it was. They pointed out that every television set requires an antenna and they were merely supplying an antenna service—not much different from a master-antenna system in an apartment house. CATV was simply a

service that delivered television signals exactly as it picked them up. Some broadcasters, however, thought otherwise. And *United Artists* hired famed attorney Louis Nizer to do battle for them.

On May 23, 1966, U.S. District Judge William Herlands handed down a historic ruling. He ruled that *Fortnightly Corporation*, which operates CATV systems in two West Virginia towns, was liable for infringing *United Artists'* copyright on films licensed by U.A. to five TV channels picked up by the cable company.

The case is presently being appealed, but it raises a storm of speculation. Will copyright fees be so high that CATV operations can no longer make a profit? How will the mechanics of clearance and fee payments—a monumental job—be handled? Industry spokesmen say that this entire area will eventually be settled to everyone's complete satisfaction.

Two major considerations have come out of the copyright issue. First, how does the copyright ruling affect the FCC rule that CATV systems must carry all local channels? Can the U.S. Government force a CATV operator to carry a channel he doesn't want, even though he has to pay copyright fees for it?

C. Stratford Smith, the Washington attorney who handled *Fortnightly's* defense says that there is a basic conflict between two Federal laws, the Copyright Law and the Communications Act.

Another Washington attorney specializing in CATV pointed out that no court has ever forced anyone to incur a liability because of Government order. But he didn't say how the conflict would be resolved.

The second consideration is program origination. If CATV operators have to pay copyright fees, it seems apparent that they should have the right to do with the program as they wish. This could include deletion of commercials. The copyright issue could easily change the entire nature of CATV, which has traditionally sent the signals along its cable exactly as it picked them up.

### The Future of CATV

With the combination of FCC regulation and copyright problems facing CATV, the future is impossible for anyone to predict. Several factors, however, indicate that CATV is likely to grow in the coming years. First is the public interest. The FCC was created in order to make sure the American public gets the maximum program variety—not to protect the interests of any group such as broadcasters or CATV operators.

The American public has made and continues to make, a very sizable investment in TV. For example, TV set sales, repairs, and electricity for 1965 totaled about \$5.6 billion. This is more than twice as much as advertisers invested in television in 1965, when some \$2.5 billion was spent for time, talent, and commercials. (Continued on page 55)

### CATV System Cost

1. Hook-on fees generally cost subscribers from \$5.00 to \$25.00.

2. Average monthly fee for subscribers ranges from about \$2.25 per month to about \$9.00 per month. Most systems charge slightly under \$5.00.

3. Service to second set in subscriber's home generally costs about \$2.00 per month extra.

4. Cost of building a CATV system head-end is about \$1200 per channel, plus about \$7000 to \$22,000 for tower and concrete "shack." The rest of the system generally runs about \$4000 per mile. Total cost of a new CATV system runs about \$100,000 to \$5,000,000, although systems in major cities will undoubtedly cost a lot more.



# How to Select MAGNETIC SOUND RECORDING TAPES

By JOSEPH KEMPLER/Audio Devices, Inc.

*Answers to the most commonly asked questions about the many types of tapes. Here is an "inside" view of the differences in performance and the reasons for these differences in the great variety of raw tape for reel-to-reel and cartridge use.*

TO the demanding user who has invested heavily in a quality tape recorder, the selection of the tape is of serious concern because of its influence on the resultant sound quality. In spite of the frequency and apparent popularity of articles on tape, many users who are by no means novices in tape recording are often puzzled and undecided when faced with a tape selection. This is certainly demonstrated by the number of letters and telephone inquiries received by tape manufacturers. The questions most often asked have little to do with base materials, thickness, lengths, or reel diameters since most recordists are quite familiar with these aspects of tape. They generally seek information on electromagnetic properties, machine-tape compatibility, differences between tape types, and so on. The description of these properties appears in print much less frequently and when it does, it occasionally leaves many questions unanswered, especially if the author presents third-hand information. The situation is not difficult to understand when one considers the many new developments in tape recording and the continuing efforts by tape manufacturers in introducing improved or entirely new products.

Logically enough, tape manufacturers are a good source of information about tape. The following discussion uses such a source, presenting the "inside" view from the tape manufacturer's standpoint. The emphasis will be on electromagnetic performance, with primary attention given to the various tape types.

Magnetic properties are the domain of the tape manufacturer and very few users have a chance of making comparative magnetic measurements on different tapes. They have to depend on listening or on comparative electrical measurements on specific recorders. This is the way it should be because the ultimate question is: How does it work on my machine?

## The Standard or Reference Tape

To compare tapes, there must be some standard which can be used as a reference. As the result of many elusive variables, magnetic tape has not reached the stage where it can become standardized like a vacuum tube or a resistor. There is no universally accepted standard reference tape which can be used for calibration or comparative record-playback measurements. As a result, anybody has the right to use any tape he wants as his standard.

Tape manufacturers are faced with the same dilemma; each would like to see his product become the "standard" for everyone to accept and follow. Accordingly, most manufacturers make a "standard" tape, if for no other reason than to distinguish it from special or nonstandard tapes.

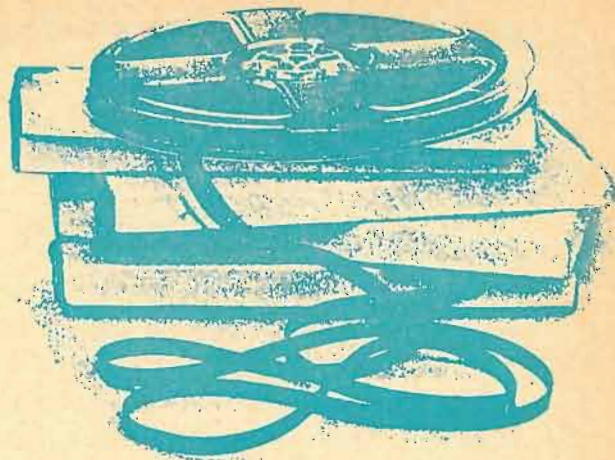

These tapes carry various designations such as, professional, standard, general-purpose, all-purpose, red oxide, conventional, or just magnetic recording tape.

Most of these standard tapes made by reputable producers are quite similar in their electrical properties. When tested on most good recorders, they produce the specified response, output, and signal-to-noise ratio. This is not too surprising because the recorder manufacturers were confronted by the same problem of standard tape. They make machines which are designed and calibrated to yield a rated performance with certain tolerances, when adjusted for a given standard tape, as chosen by the machine designer. Naturally, this situation resulted in a *de facto* standard adhered to by all tape and machine producers who wished their products to be compatible. Most tape makers, therefore, have a standard tape with a typical response as shown in Fig. 1A, obtained on a professional recorder at 7½ in/s. Standard tapes will usually have similar bias and input level requirements, very close sensitivity, distortion, and signal-to-noise ratio.

The electrical performance of standard tapes has not changed much over the years, primarily because of the tape manufacturer's obligation to adhere to these self-imposed standards. Tapes have certainly improved in consistency, reliability, uniformity, and many physical properties, but they could not change in any parameters affecting compatibility and interchangeability. For these reasons, most standard general-purpose tapes can serve reasonably well for the comparative testing of other tapes.

In the discussion to follow, the tape in Fig. 1A will be used as a standard reference. It is one of the "old reliables" used as comparison for many years.

Before leaving the subject of reference tapes it should be pointed out that there is one reference tape established and maintained by the Naval Applied Science Laboratory in Brooklyn, N.Y. for use by the government in specifying and procuring certain magnetic tapes. All tape manufacturers use this tape and, as such, it has become a common refer-

Fig. 1. Frequency response of (A) standard and (B) high-performance, all-purpose tape. Bias on professional machine was adjusted for maximum output on tape (A) at 1000 Hz. The same input level was employed for both of these tapes.

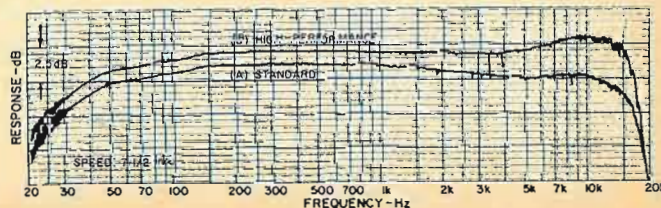



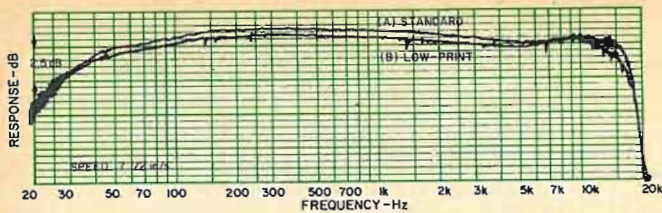

Fig. 2. Note how similar the response of the low-print tape is to the standard. All conditions are same as for Fig. 1.

ence to manufacturers and some government agencies. Public references to this particular tape are rare, except for occasional mention in tape data sheets.

### High-Performance, All-Purpose Tapes

Complaints were voiced occasionally in recent years that tapes were not getting better and required improvement. Others agreed on the need for improvements, but would not accept any changes which required machine adjustments. Pressure was applied on tape manufacturers for several reasons:

1. The continuing trend to slower speeds and narrower tracks without loss of quality made better tapes mandatory.
2. Some of the standard tapes began to show wider variation in performance than was considered acceptable. The variations, strangely enough, were not so great between different manufacturers as within the variety of standard tapes from the same manufacturer. The problem was caused by the introduction of many new lengths. For example, a change from 1200 to 1800 feet on a 7" reel required not only the substitution of a 1-mil for a 1½-mil base, but a reduction in coating thickness as well, or the tape would

not fit on the reel. Thinner coating meant lower  $\phi_r$  and output than the same type on 1½-mil base. So, if a recordist switched from 1½-mil to 1-mil base because of program length, he suffered some loss of performance. Some manufacturers solved the problem by using a coating with a higher  $B_r$  on their 1-mil base while maintaining the same  $\phi_r$ . This was only a partial solution because the variation in thickness between 1200- and 1800-foot reels resulted in different peak bias values. (For symbol meanings, see below.)

Other manufacturers resolved the problem by designing an entirely new line of products. A typical example is an all-purpose tape called "high performance" because of special performance features. The magnetic properties were improved by an increase in  $H_{ci}$ ,  $B_r$ , and squareness, all of which raise the output, particularly at short wavelengths. The  $B_r$  was high enough (1000 gauss) to allow a higher  $\phi_r$  than usual (.7 maxwell per ¼") and yet thin enough to have the same coating on all base materials and base thicknesses (440 microinches). Finally, the coating was polished to increase the high-frequency response.

The electrical results showed a number of useful features:

1. Identical electrical performance regardless of base thickness (except for print-through which changes with base thickness).
2. The same peak bias and input level as most good-quality standard tapes, thus requiring no adjustments in recorders.
3. Broader output *vs* bias curve is more tolerant of changes or misadjustments in bias.
4. Higher output and better frequency response (Fig. 1B) particularly at the higher frequencies, for better results at slower speeds and narrow track widths.

## Magnetic Properties of Tape

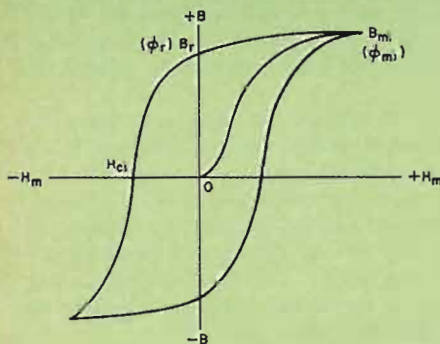

Hysteresis loop of magnetic tape showing terms discussed here. Magnetizing force,  $H_m$ , is assumed to be 1000 oersteds.

THE tape user looks at magnetic tape in terms of its electrical performance on the recorder, expecting a certain frequency response or a specified signal-to-noise ratio. The tape maker must translate these requirements into magnetic properties which, when present in the tape, will assure the specified machine performance. Since magnetism is the operating principle in tape recording, it follows that the magnetic properties determine the electrical performance of the tape. The chemical and physical attributes have a very pronounced effect on the magnetic behavior of the tape, but their main role is to assure the best possible magnetic characteristics for a given purpose.

Most tape makers design and predict the electrical performance of their products by controlling the magnetic properties throughout the manufacturing process. This control is exercised predominantly prior to the actual coating operation, because after this point the tape is largely finished and little can be done to correct any faults. The knowledge of the valid relationship between magnetic and electrical properties is, therefore, of vital importance to the manufacturer, but it should be of value to the user as well to enable him to utilize this medium more effectively. It appears worthwhile to describe briefly some of these relationships, to help the reader in forming a clearer picture as to what the tape manufacturer is doing and what parameters he is manipulating to make the tape better. It must be understood, however, that this cov-

erage is necessarily incomplete and greatly simplified, it is meant only to establish a few rules of thumb.

The figure shows a typical hysteresis loop of a magnetic tape. The symbols indicated are the ones usually listed in technical data sheets and other tape literature and are, therefore, quite appropriate to this discussion. Most data sheets specify the magnetic characteristics of a fixed magnetizing force,  $H_m$ , of 1000 oersteds. For all practical purposes, a force of 1000 oersteds is sufficient to saturate the majority of magnetic tapes. By strict definition, however, saturation is not reached until the tapes are subjected to several thousand oersteds. For this reason, the symbols shown in the figure lack the sub-index "s" which would denote saturation. For instance,  $B_r$  (residual induction) is used here instead of  $B_{rs}$  (retentivity),  $B_{ms}$  (maximum intrinsic induction) is shown instead of  $B_m$  (saturation induction). Many tape data sheets do not make this distinction and employ the saturation symbols and terminology with the tacit assumption that 1000 oersteds is indeed  $H_m$  (magnetizing force high enough to produce saturation). These side remarks may prove helpful in clearing up seeming inconsistencies among various data sheets and specifications.

### Intrinsic Coercive Force

The symbol on the abscissa of interest here is  $H_{ci}$  (intrinsic coercive force).  $H_{ci}$ , by definition, measures the demagnetizing force that is necessary to bring the induction to zero. It therefore indicates the tape's ability to resist demagnetization whether intentional or accidental. A case of intentional demagnetization is the erasure of a recording with a head or a bulk eraser; the higher  $H_{ci}$  requiring a higher erasing force for the same degree of signal reduction. Accidental demagnetization does not refer to pushing the record button by mistake, but to self-erasure of short wavelengths by the self-demagnetizing action of the recorded signal. Higher  $H_{ci}$  tape, therefore, may be expected to have reduced short wavelength losses, i.e., better high-frequency response.

In addition to defining the resistance to demagnetization or erasure,  $H_{ci}$  also determines the tape's resistance to magnetization or recording. Accordingly, a higher  $H_{ci}$  tape, when compared to an otherwise identical tape but having lower  $H_{ci}$ , will require a higher bias and record current for equal output and distortion.

Nearly all magnetic tapes utilizing gamma ferric iron oxide as the active ingredient fall within the range from 230 to 330 oersteds, with 250-270 being most common (at  $H_m$  of 1000 oersteds). Given the impetus



5. Lower harmonic distortion permits higher record levels, or protects from accidental overmodulation at normal levels.

6. No increase in print-through over standard, actually at least 1 dB lower.

High-performance and similar all-purpose tape fills a very definite need for both professional and amateur use. The tape will do everything a standard tape does but will do it somewhat better. Conservatively, it is estimated that 80% of all recording requirements could be well satisfied by the high-performance tape. Several recorder manufacturers now standardize their machines with this tape, not only for the advantages it offers but to make the machine more compatible with special tapes like low-noise types.

### Low-Print Tapes

Among the various problems plaguing the tape recordist is layer-to-layer signal transfer or print-through. Print-through occurs when a recorded signal on one layer of tape magnetizes other layers of tape immediately adjacent to it when wound on a reel. Under unfavorable conditions the printed signal will be audible as faint echoes of the printed signal and may mar an otherwise excellent recording. Print-through is a highly variable phenomenon, increasing with storage time, temperature, modulation level, accidental exposure to even very weak magnetic fields, and reduction of base thickness.

The strength of the printed signal is wavelength-dependent and reaches the maximum when the wavelength  $\lambda$  (mils) =  $2\pi d$ , where  $d$  is the over-all tape thickness in mils. For example, in a tape with an over-all thickness (coating and base) of 1.9 mils, the maximum print-through will occur at 11.9-mil wavelength. At  $7\frac{1}{2}$  in/s, this is a frequency of

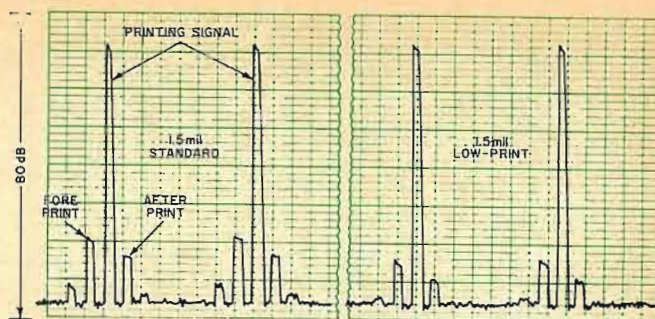

Fig. 3. Comparison of print-through for 1000-Hz pulses.

630 Hz, and at  $3\frac{1}{2}$  in/s it becomes 315 Hz. At other wavelengths, the print-through rapidly diminishes. The variability of print-through is one of the reasons why some people get gray hair over it while others never seem to have experienced it at all.

Low-print tape is a product designed to reduce print-through by about half or 6 dB when compared with a typical standard tape. A properly designed low-print tape will reduce print-through without lowering the output or affecting other desirable properties. Fig. 2 shows the frequency response of a quality low-print tape as compared with the standard.

The reduction of print-through is achieved by lowering the tape sensitivity to magnetization by weak signals *without* bias, which is the magnetization causing the printing process. At the same time, the sensitivity to magnetization by strong signals with bias, as in normal sounding recording, is fully maintained.

This feat is accomplished (in the case of one manufac-

by modern instrumentation and computer tapes which put high-frequency response and resolution as the major requirements, the industry is moving slowly but inexorably toward higher  $H_{ci}$  tapes. High coercive force tapes, 400 to 600 oersteds, are around the corner for the more exotic tapes, but it will be some time before they are used in audio work.

### Residual Induction and Flux

The second magnetic characteristic to be considered is  $B_r$  (residual induction or flux density) measured in gauss.  $B_r$  is a calculated value obtained from the expression  $B_r = \phi_r/A$ , where  $\phi_r$  is the residual flux, measured in maxwells, and  $A$  is the tape cross-sectional area in  $\text{cm}^2$ . Cross-section is the product of tape width and coating thickness.

$\phi_r$  is directly proportional to the tape width and thickness, at a constant  $B_r$ . To put it another way, the same  $\phi_r$  may be achieved with half the thickness, but doubling the  $B_r$  for the same width.

$\phi_r$  determines the amount of magnetization remaining in the tape after the magnetizing force has been removed.  $\phi_r$  thus establishes the magnitude of the playback output.  $B_r$ , on the other hand, defines the coating thickness necessary to achieve the required  $\phi_r$ .

In very general terms, the output of long wavelengths—within the limits of the 6 dB per octave unequalized playback slope—will increase with  $\phi_r$ , providing the record head is capable of biasing the entire thickness. An increase of thickness and, consequently, of  $\phi_r$  beyond this point will not raise the output any further. A tape with a higher  $B_r$  though would allow for an increase of  $\phi_r$  with no change in thickness and thus result in an increased output.

In short wavelength recording—starting beyond the peak on the unequalized playback curve—the surface of the coating nearest to the head produces most of the output. The contribution to the output of the layers farther away from the head diminish with decreasing wavelengths. The short wavelength output therefore depends on the  $\phi_r$  of the top layer of the coating. It is clear then that increasing the  $\phi_r$  by a thicker coating is useless and will not improve the high-frequency output. The solution is to raise the  $\phi_r$  within the active layer, which may be accomplished only by a higher  $B_r$ .

These examples illustrate that high  $B_r$  is generally advantageous in sound recording, especially if a full frequency spectrum is to be recorded at slow speeds. Unlike  $\phi_r$ , however, which may be changed pretty much at will simply by varying the coating thickness,  $B_r$  is subject to more limitations.  $B_r$  is limited by the available induction of iron oxide, oxide concentration in the coating, coating density, and magnetic losses. Present tapes run from about 700-1400 gauss, the most common ranging from 800-1100 gauss.  $\phi_r$  of the present tape ranges from about 0.2 to 1.2 maxwells per  $\frac{1}{4}$ -inch width, with 0.6 maxwell being typical.

The coating thickness range is from about 150 to 800 microinches, with about 450 microinches average. (Note,  $\phi_r$  must be expressed as so many maxwells per given width, predominantly  $\frac{1}{4}$  inch. Otherwise,  $\phi_r$  is meaningless.)

### Maximum Intrinsic Induction and Flux

$B_{mi}$  (maximum intrinsic induction) and  $\phi_{mi}$  (maximum intrinsic flux) have the same units and are derived in the same way as  $B_r$  or  $\phi_r$ . As the figure shows, they denote the maximum value of flux or induction while the magnetizing force at 1000 oersteds is applied to the tape. This property is an important control parameter for the tape manufacturer, but of little use per se to the sound recordist. When compared with  $B_r$ , however, it yields *squareness* as the result.

### Squareness

Squareness, as it is commonly but not quite correctly called, is the ratio  $B_r/B_{mi}$  or the numerically equivalent  $\phi_r/\phi_{mi}$ . Since  $B_{mi}$  is determined while the magnetizing force is applied, the demagnetizing losses are zero.  $B_r$  is determined at zero force where the demagnetizing losses are maximum. The ratio of these two properties is thus a measure of the internal losses in the coating. These may be caused by a variety of reasons including faulty dispersion, poor quality or damaged oxide particles, wide distribution of particle shapes, insufficient orientation, and other factors. Some tape manufacturers have special tests to determine the exact cause of low squareness, but they cannot be discussed here. The range of squareness in current tapes is from 0.63 to 0.82 (at 1000 oersteds) the typical being about 0.76. Since the ideal squareness is 1, the 0.76 indicates a demagnetizing loss of 24% resulting in a corresponding loss in  $B_r$ . Values ranging from 0.85 to 0.93 have been achieved in laboratories.

Squareness is important not only because of its direct influence on  $B_r$ , but even more so by its effect on output losses caused by self demagnetization by the signal itself. This effect is closely related to the accidental demagnetization mentioned previously in connection with  $H_{ci}$ . These two parameters, squareness and  $H_{ci}$ , must be considered together as the interaction between them can either offset or multiply the individual effects.

The matter of interrelation among the different properties is worthy of special emphasis. These interrelations are often quite complex and could lead to wrong conclusions if considered without sufficient data or without the necessary experience. Readers are advised, therefore, to be cautious in making decisions about tape quality on the sole basis of the magnetic properties as listed in tape data sheets. The rules of thumb presented here are very useful but tell only part of the story.



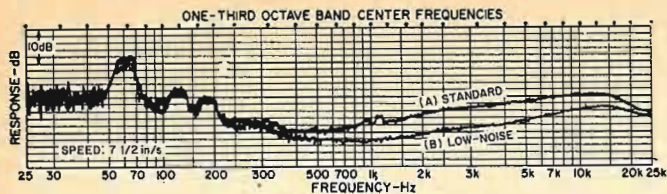

Fig. 4. One-third octave noise spectrum of biased tapes.

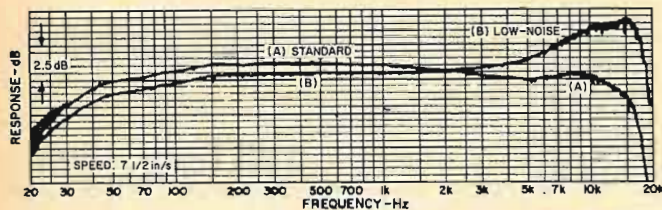

Fig. 5. Comparison between standard and new low-noise tape. Bias adjusted for maximum output at 1000 Hz using standard tape. Also, the same input level was employed for both tapes.

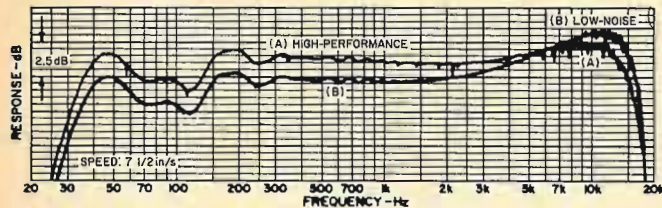

Fig. 6. Response of high-performance tape is similar at high end to new low-noise tape. Curves obtained on high-quality, quarter-track home machine with bias set to maker's specs.

turer) by a patented formulation and dispersion process and by the use of iron oxides selected for good print properties. Some of these properties are such things as reduced content of low  $H_{ci}$  particles which magnetize more easily in low fields, and superparamagnetic particles which change properties with time and temperature.

The print-through properties of standard and low-print tape are shown in Fig. 3. The signal-to-print-through ratio on the standard tape is about 51 dB and on the low-print tape it is about 57 dB, a 6-dB difference. If the same tapes were coated on 1-mil base, the ratio would drop by about 4 dB, but the difference between the tapes would be the same. Therefore, for maximum protection from print-through, 1½-mil base tape should be used. One company makes low-print tapes only on 1½-mil base for that reason.

Low-print tapes sound a little cleaner than standard tapes because of the lower level of the many compounded echoes. One strong note may have as many as 10 audible echoes which "muddy" the background quite a bit.

There is no need to change machine adjustments to use low-print tapes and they may be used interchangeably with standard tapes. Low-print tape should be used by recordists to whom print-through is objectionable or when an important recording is to be stored for a long time. High-level recording of speech and loud transients are susceptible to print-through and may use low-print tape to advantage. Many professionals prefer it for mastering purposes.

Since low-print tape does not eliminate the print-through entirely, the recordist can help matters by using caution and by following these five rules:

1. Avoid overmodulation when recording.
2. Store recording tape in a cool but not too humid location.
3. Keep tapes away from all magnetic fields.
4. Don't store tapes wound too tightly.
5. Rewind tape before each playing and at half to one-year intervals.

### Low-Noise Tapes

Another major tape problem is noise, particularly the annoying tape hiss. The advent of slow-speed recording has

made things even worse as far as signal-to-noise ratio is concerned. Many attempts were made over the years to increase S/N, usually by raising the  $\phi_r$  to produce high-output tape. This approach created some problems with print-through, high-frequency losses, and other ills associated with thick coatings, but it was the only one available.

The real attack on noise came with the introduction of low-noise tape where the tape hiss is reduced by about 6 dB. Fig. 4 shows the noise spectrum of a standard and low-noise tape in ½ octave bandwidths with no weighting. It is apparent that low-noise properties do not show up below about 300 Hz. Below this frequency, the machine noise predominates, at least on a wide-band basis. An unweighted meter will, therefore, measure the machine noise only and will not be affected by the tape at all. The ear, however, being much more sensitive to mid- and high frequencies, will readily hear the reduction of hiss in the low-noise tape.

Low-noise properties are obtained by the use of small-volume iron oxide particles with the same acicular or cigar shape, but smaller in size.

Smaller oxide particles, as a rule, exhibit higher  $H_{ci}$  and behave differently in processing. They are more difficult to disperse uniformly, leading to lower squareness. In addition, the larger surface area, per given volume, limits the oxide concentration in the coating, lowering the  $B_r$ . The result was that the early low-noise tapes required 10-15% higher bias and 2 dB additional input to make up for the losses. At the same time, the high  $H_{ci}$ , often with polished surfaces, brought the high end up, thus requiring a reduction in the record preemphasis. The low-noise tapes were incompatible with the normal machine settings but they had low-noise properties which no other tape could provide.

This situation created some problems for the users. The professionals had to set machines aside for low-noise tape only or had to readjust them if the tapes had to be changed. The machine manufacturers did not know whether to go standard or low-noise or whether to build in switches and accommodate both.

Advances in the processing technology brought some easing of the situation but it was only recently that this difficulty was resolved. The following is a description of a new low-noise tape developed by one manufacturer.

The new product is a low-noise tape with the same reduction in tape hiss, but it is compatible with standard tapes as well as low-noise tapes of other makers in many parameters. It will operate within specifications at either standard or low-noise bias and standard record level. Distortion is within the standard tape limits even at the reduced bias. No machine adjustments are needed to switch from standard to low-noise types with the exception of record preemphasis to reduce the high-frequency response. Fig. 5 shows the frequency response of the standard and the new low-noise tapes at the standard bias. The low frequencies are within 1 dB of each other, but the short-wavelength output of the low-noise tape is up 5 dB at 0.5-mil wavelength (15,000 Hz at 7½ in/s) which may cause some difficulty when using standard and low-noise tape interchangeably on the same machine.

One method of solving this difficulty is to use the high-performance instead of the standard tape since the former has nearly identical high-end response with the low-noise tape. Fig. 6 shows the frequency response on a high-quality home-type ¼-track recorder. The low-frequency output of the low-noise tape is the same as that of standard tape but it appears lower when compared with the high-performance tape. (See Fig. 1.) It is quite clear that these two tapes are compatible and may be interchanged at will on the same machine with no adjustments whatever.

Fig. 7 shows these two tapes on the same machine at 3¾ in/s. The preequalization employed by the machine manufacturer causes a fairly pronounced peak in high frequencies but this may be effectively reduced by a tone control,



thus reducing hiss by the same extent. This effect can be quite striking since the total hiss reduction is about 10 dB (6 dB from low-noise tape and 4 dB from the treble cut). Fig. 8 illustrates the extended response of both tapes even at 1 1/2 in/s. While not exactly high fidelity, it is ideal for background music and similar applications.

The method by which the new low-noise tape is produced is "classified" for the time being. The tape can be used to advantage in any application, particularly for exacting recordings or for full response at slower speeds with narrow tracks.

### Triple-Play Tapes

Demand for longer playing times on small diameter reels has given rise to new triple-play or even quadruple-play tape; that is, 3600 or 4800 feet on a 7" reel, where 1200 feet used to be normal. Triple-play tape utilizes 0.5-mil polyester base preoriented or tensilized for extra strength and coated with a 200-microinch coating.

As pointed out previously, a thin coat results in lower output, lower bias, and better high-frequency response. Triple-play tape is no exception to this rule. Fig. 9A is the standard tape under the same conditions as heretofore. Curve B is a triple-play tape tested under the same conditions as A; *i.e.*, on a machine adjusted for a standard or a compatible tape. There is a considerable loss of nearly 6 dB at the low frequencies, but with a good high end. While this loss is large, it can be offset somewhat by a higher record level because the distortion at B, being heavily overbiased, is quite low.

Curve C shows what happens when the bias is reduced, to maximize on the triple-play tape. The losses are half recovered and the high end comes up sharply. However, an attempt to record at the usual level may cause excessive distortion on loud passages. So the record level must be reduced and we are pretty much where we started. The point is, of course, that one can't expect the same performance from a thin tape as from a thick tape unless the *B*, is increased by a factor of nearly 2, which is not likely in the near future.

Nevertheless, triple-play tape should not be dismissed entirely. When used on special machines designed for thin coatings, they are capable of excellent slow-speed performance unmatched by most other tapes, although with some reduction in signal-to-noise ratio. By the use of special formulations, even this limitation may be lifted shortly.

In the meantime, regular triple-play tape should do well for slow-speed background music, monitoring, or logging. When used with caution it is suitable for just about anything except recording a live symphony orchestra. Incidentally, the thin coating keeps print-through down to a very respectable level, even if the base is only 0.5-mil thick.

Quadruple-play tape has the same coating on a 0.35-mil or thinner base. The performance is the same as in triple play except that it is flimsier and more difficult to handle when it is employed in reel-to-reel form.

### Lubricated Tape for Cartridges

Lubricated tape consists of a standard tape with a very slippery coating of dry lubricants applied to the back side. The tape is designed for use in continuous-loop cartridges such as are used mainly in automobile tape players and in some broadcast applications. The tape is not recommended or necessary for conventional reel-to-reel applications.

Most cartridge systems operate at 3 3/4 in/s or slower, crowding 4 or 8 recorded tracks onto a 1/4" tape, thus creating formidable problems in providing sufficient high-end response and signal-to-noise ratio. The magnetic component of lubricated tape, therefore, requires a good standard or better yet a high-performance product.

When used in a properly designed cartridge, a good lubricated tape will run for hundreds of passes with no jamming or binding and with wow and flutter low enough for critical recording such as piano music. Since the properties of most

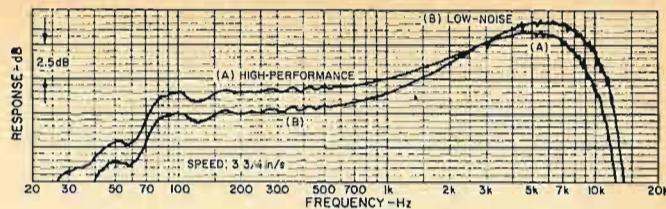

Fig. 7. Same as for Fig. 6 but tape speed reduced to 3 3/4 in/s.

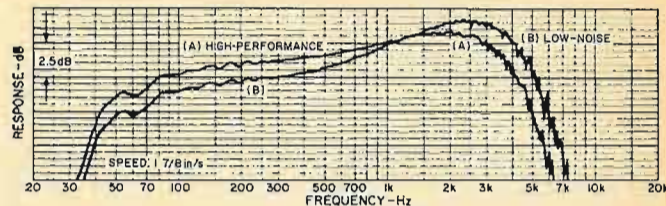

Fig. 8. Same as for Fig. 6 but at a tape speed of 1 7/8 in/s.

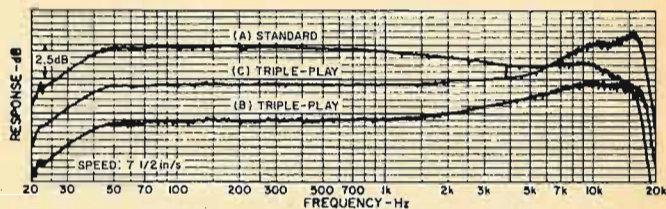

Fig. 9. (A) Response of triple-play compared to standard. (B) was obtained with bias set for maximum output on standard tape; curve (C) bias at maximum output on triple-play tape.

importance to successful cartridge operation are physical and mechanical in nature rather than electromagnetic, they will not be covered in this article.

Lubricated tape is manufactured on polyester base only, for maximum strength and temperature stability. It is supplied primarily to duplicators who record the program and then load the tape into cartridges. The quality of these recorded tapes is quite good, particularly if recorded with some of the advanced duplicating systems.

Lubricated tape is also available loaded in cartridges, 150 feet in an 8-track and 300 feet in a 4-track cartridge, for those recordists who have machines capable of recording in a cartridge.

The question is often asked whether it is possible to buy lubricated tapes and cartridges separately and then load them before or after recording. The answer is "yes". The loading process is rather tricky, however, and requires special procedures. For the benefit of those enthusiasts who wish "to roll their own", detailed loading instructions are supplied by manufacturers to the users of their cartridges.

In general, tape winders having a take-up static torque of 17 grams at 1-inch radius are used. When wound with the proper tension, a 150-foot tape cartridge should have a 6-inch "drop loop", while a 300-foot cartridge should have a 10-12 inch "drop loop." To measure this loop, insert a pencil under the tape at the playback-head opening of the cartridge and gently allow the cartridge to drop and hang free. Drop-loop length is the distance from the front of the cartridge (facing up) to the top of the pencil.

The loading can be done successfully even without special tape winders by using the take-up spindle on any recorder with reasonably close tension. It is especially important under these conditions to conform closely with the proper winding tension or the cartridge may either fail or run with excessive wow.

"Playtape" is the newest variety of lubricated tape using the usual lubricated product but slit to 125 mils or half the standard width. It has two recorded tracks on it with the same track width as used in 1/4-track recording. The tape is loaded into a smaller version of the conventional continuous-loop cartridge and functions on (Continued on page 79)





# RECENT DEVELOPMENTS IN ELECTRONICS

**Improved Artificial Quartz Crystals.** (Top left) Synthetic quartz crystals can now be grown in such a way that their properties more nearly match those of natural quartz. The improved technique increases by ten to twenty times the "Q" of the man-made stones. The new crystals can now be used to replace natural quartz crystals in all communications devices. Until now the synthetic crystals had various frequency limitations. However, by adding lithium nitrite to the normal hydrothermal growing process, "Q" rises substantially and higher frequency operation is possible. The photo shows crystal slabs being drawn from an autoclave, following a three-week process with temperatures ranging up to 700°F. The new process is used by Western Electric which produces about 20,000 pounds of quartz each year (all of it for use by the Bell System) or slightly more than 5 percent of annual U.S. requirement.



**Side-Looking Mapping Radar.** (Center) This photo of San Diego harbor was not made by an airborne optical camera but by a mapping radar. The side-looking radar has the ability to cover large areas in almost any kind of weather and at night. The aircraft carrying the radar does not have to fly directly over the area being mapped. The photo shows, in addition to the topography of the area, a "vegetation" characteristic—kelp beds that can be seen off the tip of the peninsula in the upper left part of the picture. These kelp beds are not always visible to the naked eye or to a camera even on sunny days. Because they reflect radar signals in a different way than do their surroundings, the beds are visible to the radar. Over the past two years, a large number of mapping flights have been made to obtain data on remote sensing techniques for NASA's earth science resources program. The radar equipment that is employed was developed by Westinghouse.

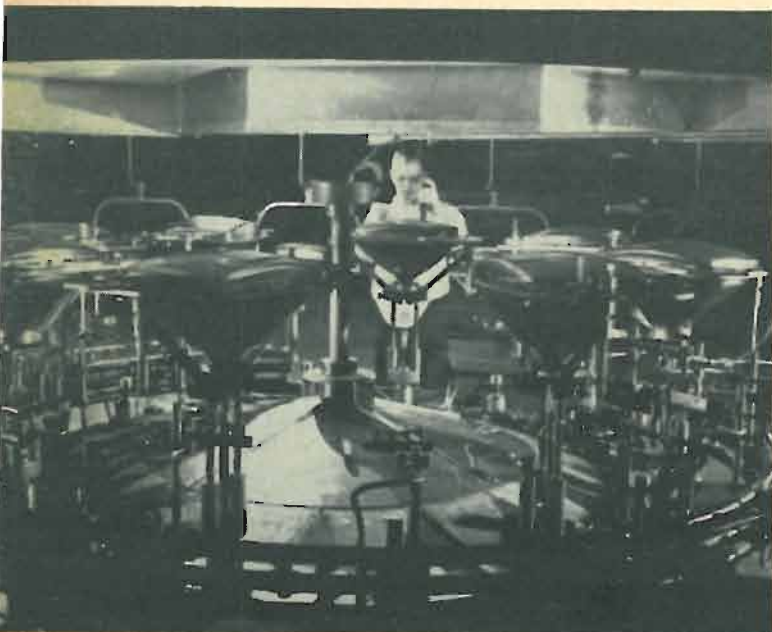

**Color Tube Sealing Machine.** (Bottom left) The electron guns of the new 22-inch color-TV picture tubes are shown here being sealed into their glass envelopes on a semi-automatic sealing machine. One of the operators of the gas-fired thermal machine is shown putting a stamp of approval on a tube faceplate. This tube size is expected to be the volume replacement for the 21-inch round color tube, which has been the industry's leader for over ten years. The operation shown is one of the many complex procedures that go into the manufacture of the important and critical color tube. The machine is in use at RCA's new \$26 million color-television picture tube plant in Scranton, Penna., which was recently dedicated.



**Electronic Sports Timer.** (Top right) A new solid-state sports timing system for use at U.S. track meets has been developed. The automated \$190,000 system (which is incidentally not for sale) provides a time-and-picture record of each runner as he crosses the finish line. When the starter fires the starting pistol, a transducer on the pistol sends a signal to a portable radio unit that sends a coded start signal to the timer's time-base generator (foreground). Not shown is the shutterless slit camera that takes a continuous picture of the finish line on a film strip that moves in the same direction as the runners. The picture simultaneously registers elapsed time in an unbroken numerical sequence of 1/100th second. The sports timer system was developed by Bulova.



**Laser Welder.** (Center) A metalworking laser is shown here producing a plume of metal vapor as the light beam vaporizes a spot on its steel target. CCTV monitor is used for magnification, safe viewing, and focusing of the beam. The laser is used at an IBM computer plant to do special welding as an engineering service in support of manufacturing operations. The laser can weld materials that resist conventional methods and can be employed to weld a good many test assemblies.



**Bonded Faceplates for Color Tubes.** (Below right) Another large new plant for producing color-TV picture tubes was recently dedicated in the state of Pennsylvania. This one is Philco's \$22 million plant in Lansdale. The photo shows the last of many steps in the involved manufacturing process required to produce a color tube. The worker is placing the laminated safety glass over the tube's faceplate just prior to bonding.

**Thin-Film Research.** (Below left) A radio-frequency sputtering chamber is used here for depositing thin films on ceramic substrates. Inside the chamber, which operates like a giant vacuum tube, a radio-frequency field is applied to a ceramic plate in the presence of an ionized gas causing ions to bombard the ceramic. Molecules are knocked from the ceramic material and are deposited in a thin film on nearby substrates (the small squares on the platform inside the chamber). Current interest at the General Motors Research Laboratories, where this photo was taken, is in developing new techniques.

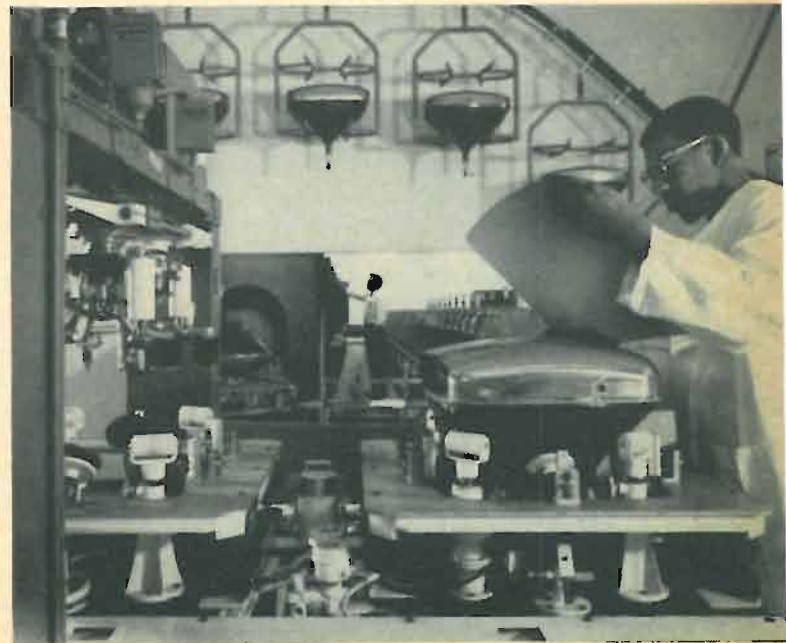
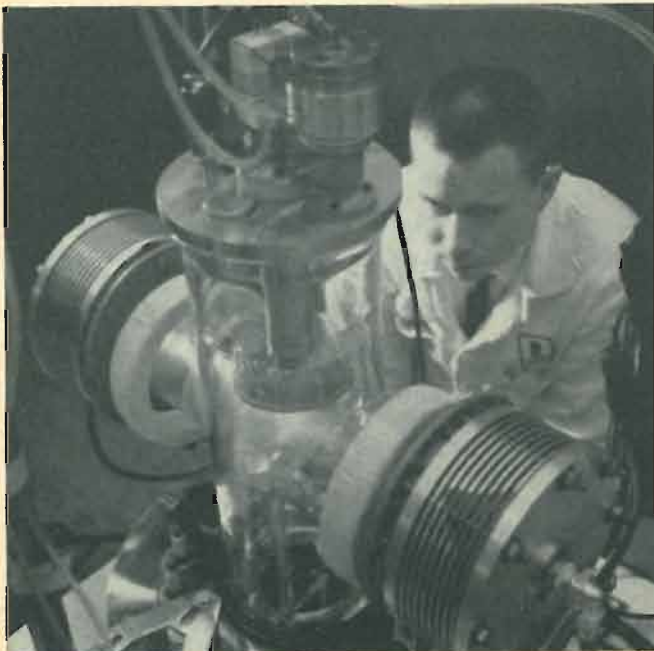



# BIASING IN MAGNETIC TAPE RECORDING

By JOHN G. McKNIGHT/Ampex Corporation

*How to select the optimum bias for best low-level response, high output, and reduction of dropouts. Bias frequencies, circuits, and problems are included.*

WHEN a magnetic field is applied to certain kinds of materials—such as the coating on a piece of tape—some of this magnetic energy is stored on the tape. In other words, the tape coating becomes a permanent magnet. The surface flux from this “magnet” can be detected without in any way changing the stored energy. This particular attribute of detecting without changing is what makes magnetic tape recording possible.

## Why “Bias”?

When we look at the relationship between the magnetizing (recording) field and the stored magnetization (Fig. 1A), a defect immediately becomes obvious—there is a tremendous non-linearity. This would cause unbearable harmonic and intermodulation distortion of recorded speech or music signals.

The earliest attempts to reduce this distortion involved applying a d.c. bias to the tape so that the linear portion of the curve from A to B could be used. Here only about one-third of the curve is used and the presence of the large d.c. magnetization made the recording noisy, thus the signal-to-noise ratio was poor.

A better d.c. biasing scheme was discovered. The tape can be magnetized to saturation in one polarity and the recording head can carry a d.c. bias which counteracts this original saturation, bringing the magnetization back to approximately zero. When an a.c. field is added, the magnetization is approximately proportional to this added a.c. value, and linear recording is achieved. However, it is difficult to exactly balance out the d.c. and some noise is left.

A much better method is that of a.c. biasing. The tape is automatically left in a demagnetized state and the full potential signal-to-noise ratio can be achieved. The principle of a.c. biasing was described (but not used for magnetic recording) by Steinhaus and Gumlich in Germany in 1915. A.c. biasing for magnetic recording was discovered but never used practically by Carlson and Carpenter in the USA in 1921, and again by Nagai, Sasaki, and Endo in Japan (1938). Practical utilization came with the re-discovery by Braummuehl and Weber in Germany in 1940.

Early papers and books on magnetic recording attempted to explain the effect of a.c. biasing through mathematical models, analogies with a class AB push-pull amplifier, and graphical models considering major and minor hysteresis loops of the magnetic material. These explanations are all somewhat magical and of doubtful value. A much clearer visualization of the effect of a.c. biasing can be gained using the process of “ideal magnetization” (also called “anhysteretic magnetization”).

For simplicity's sake, let us consider a flexible “bar magnet” made by cutting off a length of blank tape, say 4 cm long. The “bar” can be magnetized in a solenoid carrying a

known amount of direct current; the resulting permanent magnetization left after the current is removed can be measured by means of a fluxmeter. When we perform this experiment, and plot the permanent magnetization resulting from various magnetizing currents, we get a curve as in Fig. 1A, showing the great non-linearity.

Suppose that while the direct magnetizing current is applied we add an *alternating* magnetizing current, which we then reduce to a zero value before turning off the direct current. The resulting permanent magnetization is shown in Fig. 1B for different values of the alternating current. Clearly we have accomplished two things: we have greatly increased the sensitivity (the magnetization for a given d.c. magnetizing current), and we have made the magnetization a linear function of the d.c. magnetizing current. Thus, with this system, an undistorted recording can be made. In this experiment, the d.c. represents the signal to be recorded and the a.c. represents the a.c. bias. There is only one major difference in an actual tape recording. In our experiment, the a.c. field decreases while the d.c. field remains constant. If we were to use a magnetic ring-core head on a tape recorder to magnetize a piece of tape pulled past the head, we would find that the a.c. and d.c. fields would die out *together*.

If we go back to our solenoid system and repeat our experiment, but now with both fields decreased simultaneously, we would find the curves of Fig. 1C. Increasing the a.c. up to a certain point has the same effect as before but beyond this point the magnetization decreases.

This magnetization process is exactly equivalent to what actually happens in a tape recorder at low frequencies. At high frequencies, on the other hand, the process becomes very complicated, because the d.c. (signal) field is changing while a particle of tape passes across the recording gap. Fig. 1D demonstrates the 1000-Hz output of a tape recorder at 38 cm/s (15 in/s). Increasing bias current increases the output up to the point of maximum sensitivity (also called “peak bias”), then further increases in bias current decrease the output.

The choice of the “best” bias current for practical operation of a tape recorder depends on several factors, because the bias current affects not only sensitivity but also the frequency response and the distortion of the recording process.

One extremely important fact must be pointed out here: all of the relationships in biased recording depend on the relative dimensions of the tape-coating thickness, the recording head gap length, and the recorded wavelength.

1. The tape-coating thickness ranges from about 5  $\mu\text{m}$  (0.2 mil) for triple-play tape through 12  $\mu\text{m}$  (0.5 mil) for standard tape, to about 22  $\mu\text{m}$  (0.87 mil) for high-output tapes. The ratio of the thickest to the thinnest is 4 to 1.

2. The recording head gap length ranges from 1.5  $\mu\text{m}$



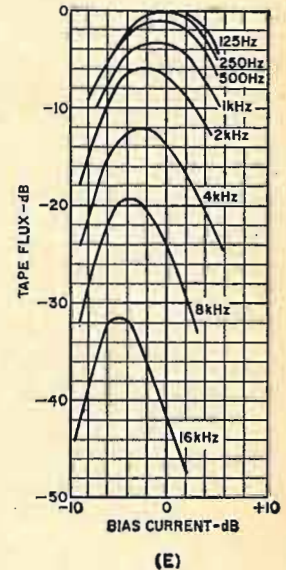
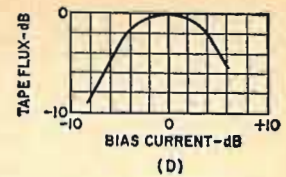
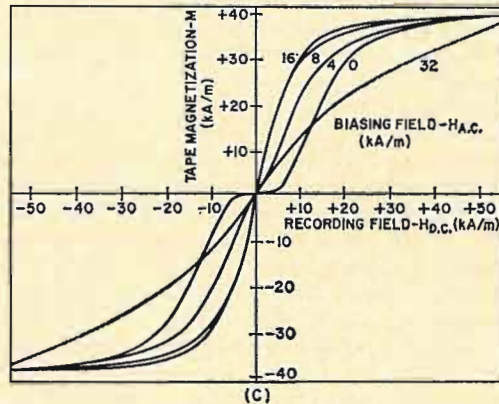
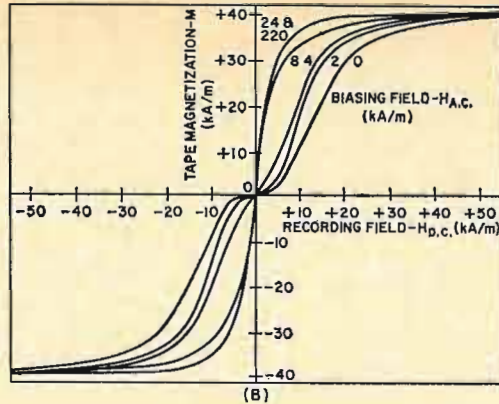
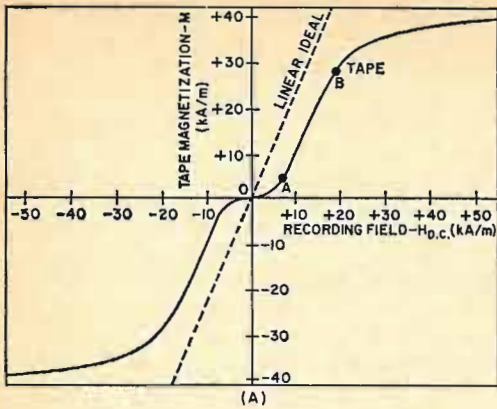

Fig. 1. (A) An unbiased tape is inherently non-linear. (B) When a.c. bias is added in various amounts to the d.c. (signal), the curves are as shown. In this case, the d.c. remains while the a.c. decreases. (C) Same as (B) except that both d.c. and a.c. decrease, simulating actual tape recorder. (D) Output rises with increasing bias to a peak then falls off. (E) Output vs bias current at a number of frequencies using unequalized (flux-sensitive) system, showing the shift required in the bias for maximum high-frequency sensitivity.

(60  $\mu$ m) for slow-speed, combination-head recorders, through 3  $\mu$ m (120  $\mu$ m) for normal combination-head recorders, to 25  $\mu$ m (1 mil) for professional recording-only heads. The ratio of longest to shortest is 16 to 1.

3. The recorded wavelength (= tape speed in recording/frequency in recording) ranges from 4  $\mu$ m (160  $\mu$ m) to 500  $\mu$ m (200 mils) at 4.76 cm/s (1 1/8 in/s) for a frequency range from 12 kHz to 100 Hz and from 25  $\mu$ m (1 mil) to 10 mm (0.4 in) at 38 cm/s (15 in/s) for a frequency range from 15 kHz to 40 Hz. Altogether the ratio of wavelengths is 2500 to 1!

In the day when recording was primarily professional, that is, 38-cm/s (15 in/s) speed, with 12- $\mu$ m (0.5-mil) tape coating, and 25- $\mu$ m (1-mil) recording-head gaps, one could show general relationships and draw general conclusions for optimum operation. Things are not now so simple. We shall have to be content to show specific trends for specific conditions, and simply realize that other conditions will yield different data and conclusions.

The particular magnetic properties of the tape coating are also important and they affect the frequency response, distortion, and the signal-to-noise ratio that is obtained.

### Effect of Bias on Frequency Response

A basic unequalized experimental recorder would use con-

stant recording head current *vs* frequency to produce a constant recording field *versus* recording frequency. A basic unequalized experimental reproducer would have an output proportional to the flux on the tape. For instance, by means of a loss-free short-gap ring-core reproducing head plus an integrating amplifier with constant flux, the head voltage rises 6 dB per octave. But the integrating amplifier response falls 6 dB per octave. Therefore, the two effects compensate and the output voltage is flux-proportional.

Suppose we draw the output *versus* bias current curve at a number of frequencies, as in Fig. 1E. We would see these things: 1. At all frequencies, the output rises with rising bias current, then falls off. 2. The current for maximum sensitivity is the same over a wide range of *low* frequencies (long wavelengths), then, as frequency increases (wavelength becomes shorter) the maximum sensitivity occurs at lower and lower currents.

This data can be re-plotted as a frequency response (Fig. 2A). The generally drooping characteristic shows that the system must be equalized to compensate for short-wavelength losses. Fig. 2B shows the relative responses if the recording field were changed to give the same tape flux at low frequencies for each bias current. We see that low bias current gives the *least* high frequency losses, and therefore would require the least amount of equalization. Therefore,

Fig. 2. (A) Frequency response with different bias currents showing the need for equalization. (B) Same as (A) but with outputs at low frequencies adjusted to same level. (C) Same as (A) but with the system equalized for a flat response when the bias has been adjusted to provide the maximum sensitivity at low signal frequencies.

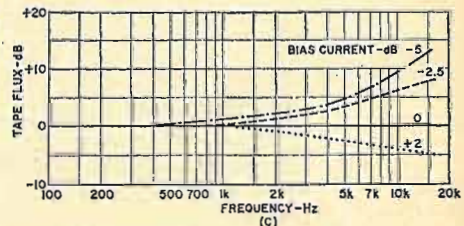
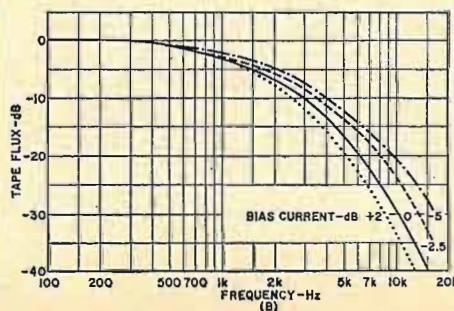
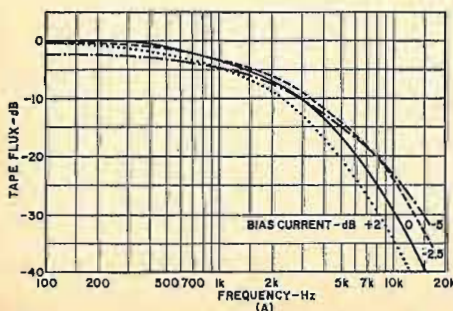



from *only* a frequency-response standpoint, biasing for maximum sensitivity at the highest frequency would be best. When the system is equalized for the maximum low-frequency sensitivity bias point, changes of bias would change the equalized response as shown in Fig. 2C. Lowering bias increases high-frequency response and *vice versa*.

### Effect of Bias on Distortion

Fig. 1B shows that at low bias the curves are non-linear and with increasing bias they become more linear. The measured harmonic distortion at low frequencies shows this effect (Fig. 3A).

Harmonic distortion measurements above one-third of a recorder's bandpass are, of course, meaningless since the distortion (primarily third harmonic) is eliminated. High-frequency non-linear distortion can be measured, however, by the CCIF intermodulation method. Two equal-amplitude high-frequency tones, say  $f$  and  $f + \Delta f$ , are used. If we let  $f = 300$  Hz, then the frequencies could be 10,000 Hz and 10,300 Hz. In the output, we look for the second-order intermodulation frequency component at  $f - \Delta f$ , which would be 9700 Hz in this case. This frequency is caused by the same non-linear phenomenon which causes third-harmonic distortion, but this frequency is *inside* the system bandpass. Fig. 3B shows the output for 2% IM distortion *versus* bias current, for 500-Hz, 2500-Hz, 5000-Hz signals, using a 9.5 cm/s (3 3/4 in/s) tape speed, standard tape, and a 5- $\mu$ m (200  $\mu$ m) combination recording head gap length. The 0-dB bias current is that which gives maximum sensitivity at 500 Hz.

This data shows the difficulty of improving the high-frequency response by lowering the bias current. The response at lower levels is improved (see Fig. 3B), but the maximum output for a given distortion at mid-frequencies is greatly diminished. Operation at -3 dB bias, for instance, increases the 5-kHz maximum output by almost 3 dB, but decreases the 500 Hz maximum output by 4 dB, thus the mid-frequency signal-to-noise ratio is compromised in order to gain improved high-frequency performance. With separate recording heads, the problem still exists, but is not so severe.

### Effects of Bias on Dropouts

When recording, a tape nodule or a dust particle causes the tape to be lifted away from the recording head, the biasing field is, in effect, decreased. If the system is under-biased (say at -2 dB in Fig. 1D), then a small loss of bias causes a large loss of recording sensitivity, and a large drop-

out of the recorded signal at all frequencies. If, on the other hand, the system were operated in the overbiased condition (say at +2 dB of Fig. 1D), the loss of contact would decrease the biasing field, but this would result in a compensating *increase* in recording sensitivity, thus the dropout would be reduced.

Hence, we have a conflict—best response at low levels dictates low bias current, greatest output for a given distortion dictates a medium bias current, and reduction of dropouts dictates a high bias current. In professional recorders, high-speed recorders with separate recording heads, there is little problem. Best operation comes from biasing at 0 to +2 dB *re* bias for maximum sensitivity at low frequencies. In home recorders—slow-speed recorders with combination recording heads—there is a real conflict and some compromise must be made. Different equipment manufacturers do this differently and extended frequency response may mean high distortion.

### The Bias Frequency

The bias frequency should be as high as possible for two reasons. First, lower bias frequency causes the background noise to increase: at 19 cm/s (7 1/2 in/s) tape speed, the use of bias frequency of about 100 kHz (or more) reduces this noise to nearly the minimum amount. Second, at high recorded frequencies, the harmonic distortion which is created at high recording levels by the tape and recording amplifiers produces audible beats with the bias frequency and these beats are recorded on the tape. A frequency-response run at high levels may look like Fig. 3C. The response above about 8 kHz is, in fact, a series of bias beats. This 4.75-cm/s (1 7/8 in/s) recorder uses a 67-kHz bias frequency.

This problem may be especially troublesome when one attempts to make tape recordings from an FM-multiplex tuner. Both 19- and 38-kHz signals are present in the multiplex unit and may get through to the tape recorder. If these are of large magnitude, the bias beats will occur. Several solutions are possible including better filtering of the multiplex carrier in the tuner and low-pass filtering in the tape recorder input circuit. If the multiplexer is well-balanced, so that only the 38-kHz is of concern, the choice of a 95-kHz bias frequency will place the beats above the audible frequency range.

If the bias waveform has even-order harmonic distortion, a d.c. signal is recorded on the tape. This has the bad effect of causing second-harmonic distortion as shown in Fig. 3D. A tape noise is also added, as shown in Fig. 3E. The noise consists of "cracks and pops" (*Continued on page 75*)

Fig. 3. (A) Low-frequency third-harmonic distortion. (B) Maximum output for 2% second-order CCIF IM distortion. Reducing bias for improved high-frequency output results in reduced low-frequency output. (C) High-level frequency response showing "bias birdies"—spurious outputs above 8 kHz in this 1 7/8 in/s recorder with 67-kHz bias frequency. (D) Second harmonic distortion due to bias distortion in current. (E) Noise in recording also due to bias distortion in bias current.

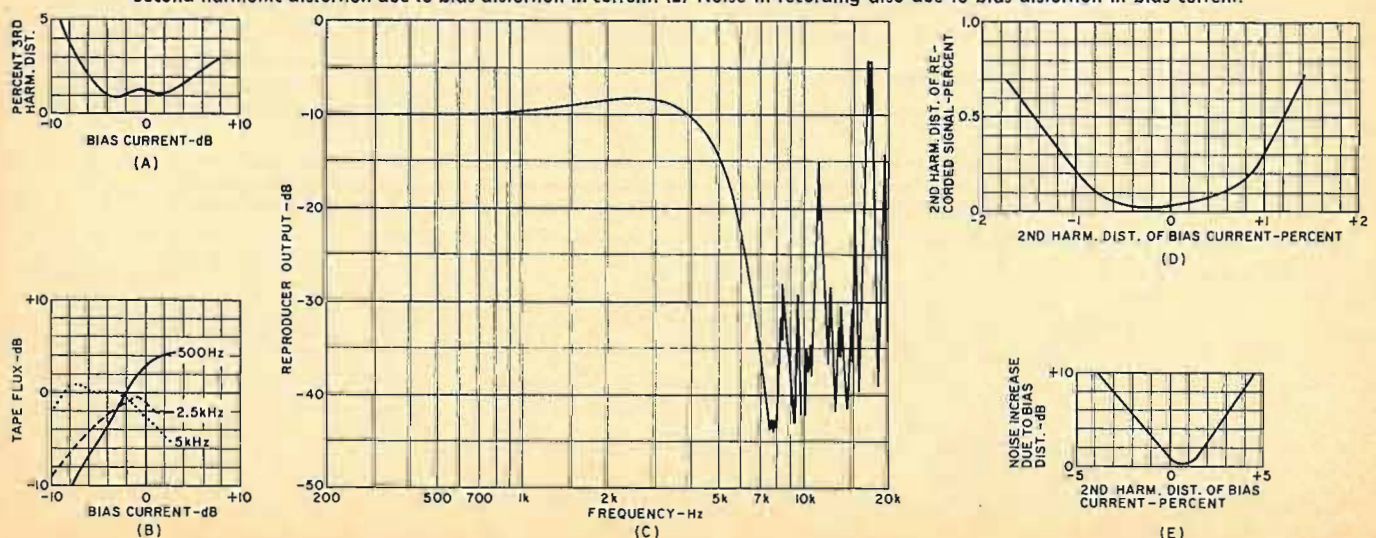



# TROUBLESHOOTING INTEGRATED CIRCUITS

## PART 2. NEW TEST-EQUIPMENT TECHNIQUES

By WALTER H. BUCHSBAUM and WILLIAM D. HENN

*Here is a practical approach to troubleshooting the IC's that are now beginning to revolutionize new consumer electronic products. Dynamic test methods using inductive coupling and signal tracing prevent damage to IC's and do away with need to unsolder any of the connecting leads.*

**T**HE problems of troubleshooting consumer products which use IC's were covered in some detail in last month's issue. In this article we will describe some dynamic testing methods necessary for efficient IC servicing. We showed last month that it is quite difficult to make connections between test equipment and the circuit under examination and discussed the possibility of circuit damage due to excessive test currents or voltages.

To eliminate the need for physical connections, inductive coupling can be used in many cases. Where physical connections cannot be avoided, they can usually be made to the leads of capacitors or resistors. Instead of such static tests as ohmmeter measurements, dynamic tests with absolutely safe signal levels are suggested. The test techniques described in the following paragraphs are suitable for all types

of circuits and will also often prove useful when transistors are involved instead of integrated circuits.

### Typical Application

Fig. 1 shows two IC's in a 10.7-MHz i.f. strip, a typical application in an FM tuner or, with a frequency change, in a TV i.f. section. It would be very difficult, if not impossible, to troubleshoot this circuit without removing components. Yet we will demonstrate that all parts can be tested without unsoldering any connections, without damaging the IC's, and with reasonable speed. The basic philosophy in any IC troubleshooting technique is to assume that the IC's are good and check all external components first.

As an example, suppose the symptom is loss of audio. The trouble might be an open primary in T3. Removal of T3 and

## IC SERVICING: IN THE HOME OR IN THE SHOP?

**T**HE accompanying article on servicing IC's deals only with the technical facts and deliberately ignores the question of whether such servicing should be done in the customer's home or whether the advent of IC's means that every set will have to be taken to the shop. A number of factors, including the capability and preferences of individual technicians, will determine the ultimate practice of servicing IC's.

The first consideration is the test equipment required. The technician will have to take along his tool box and, instead of the customary tube caddy, he may have to carry a portable scope, a sweep generator, a pulse generator, and a v.t.v.m. It goes without saying that the chassis will have to be removed from the cabinet. This may be a relatively simple job since chassis using IC's should be quite compact. The thought of lugging all of this test equipment, together with the tool box and a box containing spare parts, from the car into the customer's home and then back again will certainly deter many technicians from attempting to troubleshoot equipment using IC's in the home.

The test equipment problem may be overcome if test equipment manufacturers market a single compact unit which includes the functions of the scope, sweep generator, pulse generator, and v.t.v.m. Such test equipment is entirely feasible if IC's and other solid-state devices are used exclusively. If such a tester were compact enough it would encourage the technician to service IC's in the home or perhaps in a fully equipped service truck used as a "laboratory on wheels."

A major difficulty, however, is that any replacement of defective components, particularly the IC itself, requires precision soldering of many extremely small and deli-

cate wires. Most technicians would prefer to do this on the bench rather than in the customer's home. It is possible that this limitation can be overcome by special unsoldering and soldering fixtures and, possibly, by more convenient mounting of the IC's. Since replacement IC's and the few discrete components (resistors, capacitors, and coils) are more compact and lighter than vacuum tubes and the components used with them, it should be easy to carry along an adequate supply of spare parts. Thus it may be feasible, in the near future, to service IC circuitry in the customer's home or in the service truck.

Before concluding on such an optimistic note, we must consider some aspects of the equipment itself. With the use of IC's TV receivers, radios, and hi-fi sets will certainly become smaller, more compact, and much lighter. Presumably such equipment will be much more reliable and there will be fewer failures. When such failures occur, however, the owner may be motivated by the very compactness of his equipment to bring it to the service shop, as is currently the practice with portable TV receivers and small radios. If a local technician has enough business brought into the shop, he may decide to give up house calls altogether. Thus it is possible that these factors, irrespective of the test equipment and soldering problems, will eventually move the service business from the home directly to the shop.

We can only be sure that the advent of IC's will not spell the end of service problems. We can also be sure that the man who in the past solved most troubles by tube replacement will either have to learn the newer principles of electronics and IC operation or get out of the radio, hi-fi, and TV servicing business.



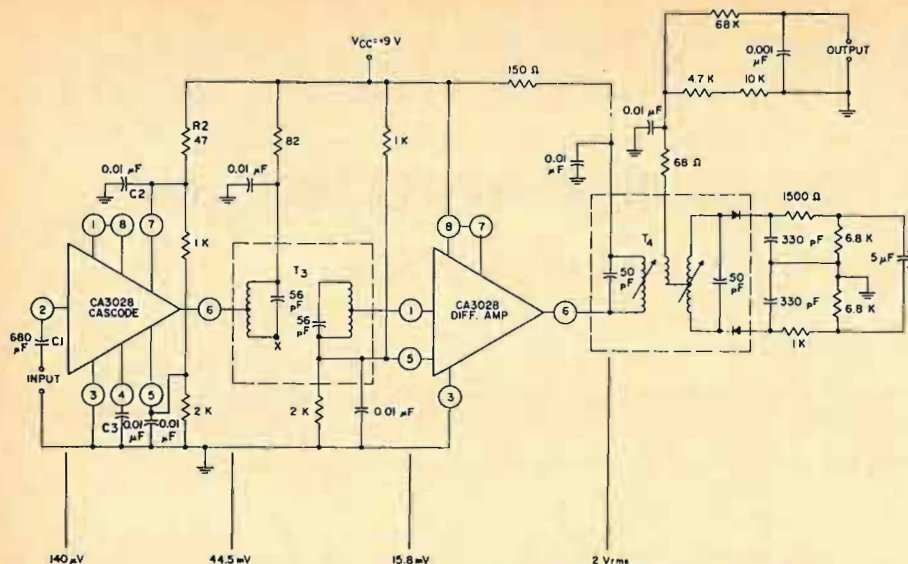

Fig. 1. A typical 10.7-MHz i.f. strip employing a pair of integrated circuits.

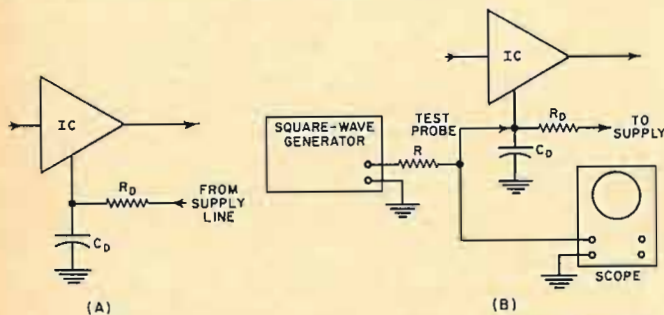

Fig. 2. (A) Decoupling network. (B) Bypass capacitor testing.

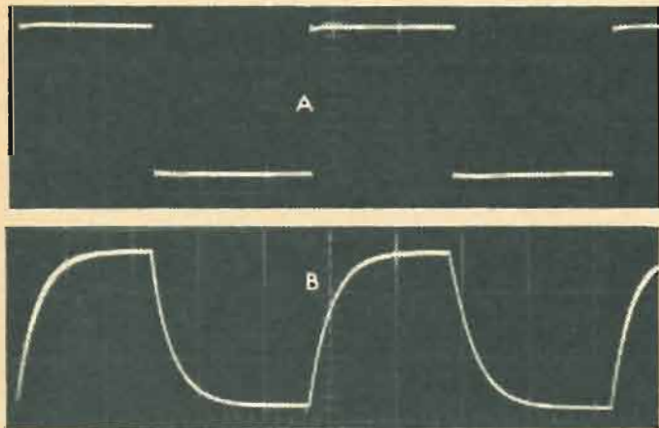
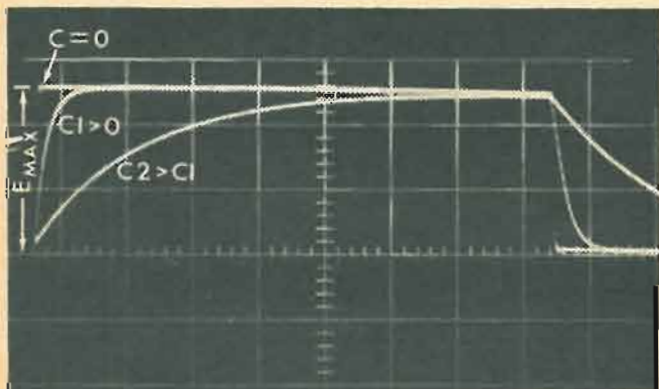

Fig. 3. (A) Input square wave. (B) The voltage across capacitor.

Fig. 4. The larger the capacitance the greater will be the slope of the leading and trailing edges of the applied square wave.



a d.c. check of the primary would be troublesome and might not show the defect since the break could be between the center-tap and point "X" which is not accessible. This defect may be found, however, by inductively coupling a sweep generator and oscilloscope to the primary of T3 and noting whether or not a resonance condition is obtained. The tuning capacitor could also be at fault and, again, a resonance check would discover this fact. Replacement of T3 is called for.

The loss of audio could also be due to a defective external capacitor. As a matter of fact, capacitors fail more frequently than coils and a dynamic method for testing the various bypass and coupling capacitors in the circuit will be described next.

(Editor's Note: It is assumed, of course, that voltages have been previously checked against maker's data.)

### Capacitor Testing

Capacitors fall into three classifications: bypass or decoupling capacitors used on d.c. supply lines, coupling capacitors between IC chips, and capacitors forming parts of tuned circuits. All of these can be tested in the circuit with power "off" and without the need for electrical isolation from the IC. We only need a square-wave generator, a resistor, and an oscilloscope.

Fig. 2A shows a common RC decoupling network formed by  $C_D$  and  $R_D$ . If a square wave is applied to the capacitor through a suitable resistance, the voltage waveform then appearing across the capacitor can be used to check the capacitor for proper value, as shown in Fig. 2B. The square-wave amplitude need only be large enough to obtain a suitable deflection on the scope, thereby precluding the possibility of overloading the IC. If the test probe is removed from the capacitor, the waveform of Fig. 3A results while connection to the circuit modifies it to yield Fig. 3B. This is due to the slow charge and discharge of the capacitor under test. The higher the capacitance for a given value of  $R$ , the slower the transition time and *vice versa*, as shown in Fig. 4. Table 1 lists some typical values of  $R$  for a range of values for  $C_D$ .

It is a well-known fact that it takes approximately four time constants ( $4RC_D$ , seconds) for the voltage across  $C_D$  to reach within 1 or 2 percent of its final value. Therefore, knowing the value of  $R$ , it is possible to calculate the actual value of  $C_D$  by measuring the time it takes for the voltage across  $C_D$  to reach this value. A more accurate method makes use of the risetime measurement. The risetime of a voltage is the time it takes for the voltage to go from 10% to 90% of its final value. This measurement is shown in Fig. 5. The risetime,  $t_R$ , is related to the product of  $R$  and  $C$  by the relation  $t_R = 2.2 RC$ , hence by knowing the risetime and  $R$ , we can calculate the value of  $C$  since  $C = t_R/2.2 R$ .

Returning to the problem of troubleshooting the i.f. circuit of Fig. 1, we use the test arrangement of Fig. 6 with  $R = 1000$  ohms. The risetime is measured as  $22 \mu\text{s}$  and the value of  $C_2$  is therefore  $0.01 \mu\text{F}$ . The peak amplitude of the waveform in his case would be approximately 50 mV for a one-volt peak input. This is the result of the approximate 1:20 ratio between  $R_2$  and  $R$ . Figs. 3A and 3B show actual scope traces for this test. Fig. 3A is the applied square wave and Fig. 3B is the voltage across  $C_2$ .

If the reader plans to use this measurement technique often, it will be worthwhile to set up the scope and square-wave generator on the test bench and measure the risetimes for various combinations of  $R$  and  $C$ . Either a decade capac-



itor box or a substitution box can be used to quickly switch in various values of  $C$ . One can put a piece of clear plastic over the CRT and trace the waveforms on it with a marking pencil as  $C$  is varied. The result will be as shown in Fig. 4. We can now measure capacitors in the circuit by placing the proper overlay on the scope and seeing where the trace falls.

Figs. 7A and 7B show two typical coupling capacitor configurations. Since the input side of the capacitor in Fig. 7A is already at a d.c. ground by virtue of the tank coil, the test probe can be placed at the input terminal of the second IC. Fig. 7B shows an untuned configuration. Here it is necessary to ground the input terminal of the second IC and connect the probe to the output terminal of the previous IC amplifier. The same rules and waveforms apply as described previously for the bypass capacitors.

### Inductors and Signal Tracing

When it is necessary to check the signal path through an IC that is operating at radio frequencies with tuned input and output coils, the problem of signal injection arises. To get accurate results the circuit must be disturbed as little as possible. This is similar to the problem of signal injection when working with a vacuum-tube TV receiver. The technician usually injects the output of the sweep generator into the r.f. mixer tube by ungrounding its shield and connecting the signal generator between it and ground. This is capacitive coupling.

For IC equipment a similar method is suggested, using coupling to the tuned circuits. To get inside the i.f. shield cans, a ferrite rod, about  $\frac{3}{16}$ " in diameter with a small coil scramble-wound on one end, is recommended. Table 2 shows the number of turns of #32 wire for some typical i.f. frequencies. The ferrite rod must have a fairly high "Q" at the frequencies used. Trimmed down tuning slugs from old i.f. coils will do, but a 455-kHz slug may not work well at 45 MHz. If the circuit under test uses unshielded coils, an air-core coil of sufficient diameter to fit over the tuned coil can be used and will cause less detuning than the ferrite-cored coil.

The ferrite rod should be long enough to allow penetration inside the i.f. cans of the circuit being serviced. This coil, driven by an r.f. sweep generator, and an identical coil used in conjunction with an r.f. detector probe on the scope, make an excellent means of inductively coupling in and out of the circuit under test. Since the coupling is purely inductive, there is little danger of damaging the IC by applying excessive voltages or currents or touching the wrong pins.

The sweep generator should be terminated by the proper value of resistance and then connected directly across the input coil. Most commercial sweep generators provide an output cable that already has the proper termination built into the probe end of the cable. The pickup coil should be shunted by a 1000-ohm resistor and connected to the scope through an r.f. probe or, if none is available, the circuit shown in Fig. 8 can be constructed. Almost any type of diode, such as the 1N60, can be used.

To test the operation of the input and output coils, the sweep generator should be set for maximum output, maximum sweep width and connected to the horizontal scope terminals in the same way as is done for the i.f. alignment. Next the two coils are brought together, as in Fig. 9, until a sufficient deflection is observed on the scope. The resulting deflection on the scope is the frequency response of the test jig (2 coils plus detector). Remember that the scope displays a signal that varies periodically at a 60-Hz rate. The trace should be a reasonably straight line since any tendency for coil resonance is damped out by the low value shunt resistors across the input and output coils.

Once the generator and the detector are coupled to the circuit under test and a scope trace is obtained, significant frequencies on the response curve can be checked with a

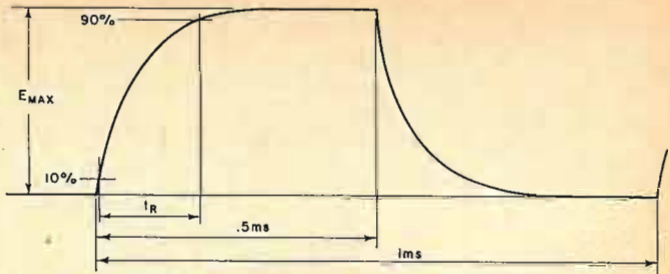

Fig. 5. Risetime measurements using a 1000-hertz signal.

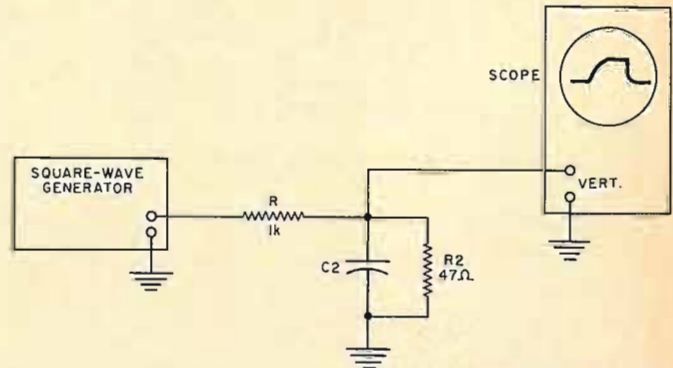

Fig. 6. Test-equipment setup to check capacitor C2 in Fig. 1.

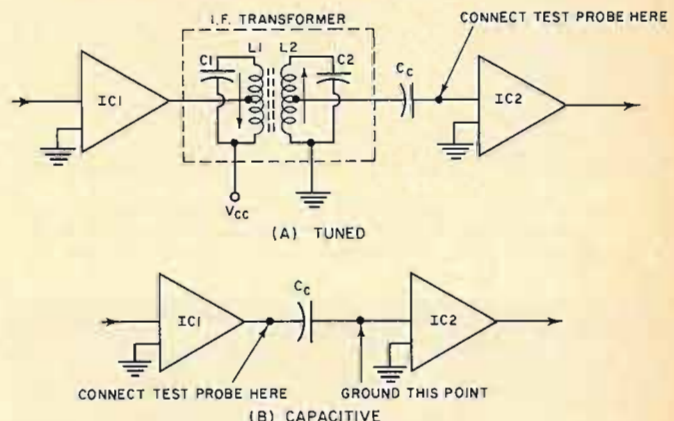

Fig. 7. Test-probe locations for two methods of IC coupling.

C ( $\mu$ F)	R (ohms)	MAX. TEST FREQ.	$t_r$
150	180	2 Hz	59.4 ms
10	180	20 Hz	3.96 ms
0.1	1000	400 Hz	220 $\mu$ s
0.01	1000	6 kHz	22 $\mu$ s
0.001	1000	40 kHz	2.2 $\mu$ s

Generator output impedance: 75 ohms.  $t_r = 2.2 RC$ .

Table 1. Typical values of series resistors for various C values.

Table 2. Turns needed for inductive probes at various frequencies.

FREQUENCY	NO. OF TURNS
262-455 kHz	200
4.5-10.7 MHz	100
45 MHz	75

Use #32 insulated wire for coils, scramble-wound on 3/16" ferrite core.



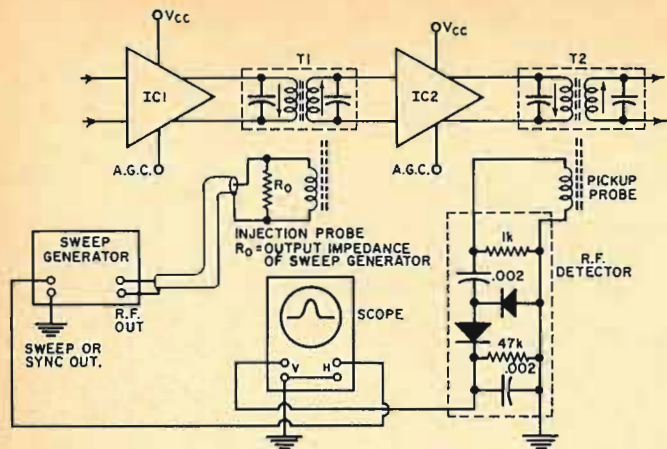

Fig. 8. Setup for testing signal path through IC i.f. amplifier.

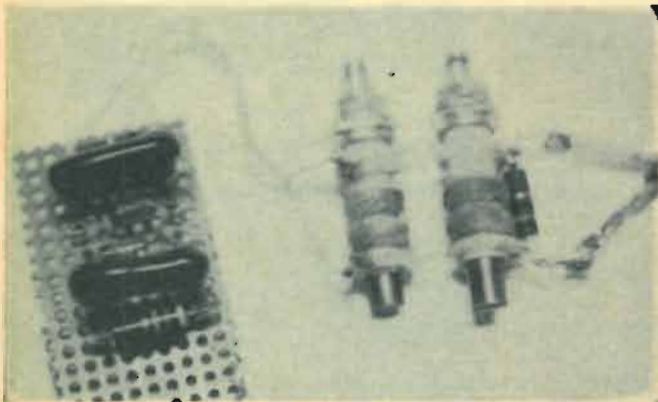
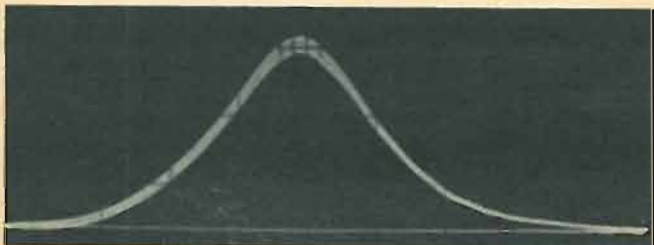

Fig. 9. Detector circuit (left) is shown connected to the pickup coil. Injection coil along with its loading resistor are at right. Commercially available coils and coil forms can be used.



Fig. 10. Pickup coil (left) and injection coil are stuck into i.f. transformers to which these inductive probes are coupled.

Fig. 11. Response of FM i.f. amplifier using technique described.



marker generator or with built-in markers in the same manner as in aligning transistor or vacuum-tube i.f.'s.

Again a word of caution—use only the minimum amount of coupling in and out to effect an output indication. Remember that the ferrite test coil will affect the tuning of the circuit to which it is coupled. Using minimum coupling (maximum separation) between the test coil cores and the tuned circuit to be tested will minimize this effect. It is better to use maximum output from the sweep generator and higher scope gain to permit loose coupling. Fig. 8 shows the test setup for a typical TV or FM receiver i.f. stage and Fig. 10 shows the actual arrangement used to obtain the curve of Fig. 11. As in transistor or vacuum-tube circuits, the "B+" must be "on" and the a.g.c. bias must be set to its proper value. The conventional a.g.c. battery box can be connected to the main a.g.c. bus and set to the voltage recommended for i.f. alignment.

When using this technique to view the individual stage response in a cascaded amplifier, it should be remembered that one will see not only the response of that stage but also that of the associated primary and secondary windings. For instance, in Fig. 1 if the generator were coupled to the secondary of T3 and the scope to the primary of T4, the scope trace will include the effect of the primary of T3 and the secondary of T4. If traps are in the circuit, their effect will appear on the scope as well. To verify the operation of the traps they can be detuned and the difference noted on the scope trace. It is important to remember to check the over-all alignment of the i.f. after the troubleshooting is completed and the defect has been eliminated.

When a resonance check on a single unshielded coil is required, it will be easier to use a grid-dip meter for this purpose. A grid-dip meter is commonly used by hams and in laboratories as a quick check on the resonant frequency of tuned circuits. It consists of an oscillator which is manually tuned across the band of frequencies of interest. In order to provide coverage over a wide range of frequencies, the tank coil is plugged into the case of the unit and several plug-in coils are supplied. The grid current of the oscillator is monitored by a self-contained microammeter and the tank coil is coupled to the tuned circuit to be tested. The frequency of oscillation is varied manually and when the resonant frequency of the test circuit is reached, it will absorb the energy from the oscillator tank, thus reducing the amplitude of oscillation and causing the grid current to drop. When the point of minimum grid current is reached, the resonant frequency can be read off the calibrated dial of the grid-dip meter.

Grid-dip meters are readily available to the service technician and inexpensive models in kit form would make a worthwhile, inexpensive addition to any service bench.

### Conclusion

Although these dynamic servicing techniques are presented here in connection with troubleshooting IC's, they can of course be used to advantage in servicing circuits composed of discrete components. One advantage claimed for these methods over those previously used is that no components must be unsoldered just to permit testing. Another advantage is that no special new test equipment must be purchased by the technician, since the construction of a few simple adapters allows him to use existing bench equipment to troubleshoot IC's as well as resistor and tube equipment.

The authors hope that this series on IC servicing has demonstrated that the revolution which IC's are supposed to cause in the service shop will not lead to complete obsolescence of test equipment. The use of IC's in consumer equipment will, however, require the technician to change his philosophy of servicing and to use his ingenuity and knowledge of basic electronics to cope successfully with the new problems inherent in IC's.





# VALUE ENGINEERING FOR THE ELECTRONICS INDUSTRY

By FRED H. POSSER/Director of Value Engineering  
Airborne Instruments Lab. (Div. Cutler-Hammer)

*A management philosophy of applying a forced organized approach to reducing costs while maintaining product quality. Many examples are included, showing what creative thinking can do in this area.*

VALUE engineering is an organized attack on all elements which affect cost in order to provide a required function or product at an optimum price. These techniques can be applied to hardware, processes, schedules, or procedures. Since there is much confusion in the field, let us differentiate between value engineering and some of the other terms that appear to be part of this subject.

*Value analysis* is the application of the techniques and philosophies of value engineering to *existing* designs or products. In many companies the terms "value engineering" and "value analysis" are used interchangeably, but we prefer to separate them and consider value engineering the application to new designs and value analysis the application to existing designs or products.

*Cost reduction* is the effort made to reduce the cost of a required item by analyzing the fabrication techniques and procedures necessary for its production. This means we do not consider ways of changing what is specified or required, but rather investigate methods of obtaining what is required at a lower cost. When this investigation is applied to the item's or procedure's *function* after the item has been designed, we call it "value analysis". When it is applied to the function of an item still to be designed, we call it "value engineering".

*Cost effectiveness analysis* refers to optimizing the total cost of a product or a system, *i.e.*, user's cost to purchase, service, repair, maintain, and satisfy the staffing requirements of a piece of equipment or system for a specified number of years.

PERT is a technique for analyzing the occurrence of sequential and parallel events or operations in order to determine the path that is most critical in establishing the required output. Value engineering may be used to reduce or investigate the cost of specific events.

*Zero defects* is a philosophy emphasizing each individual's importance in doing a job right, the *first* time. Zero-defects philosophy, therefore, applies to everything, including how the value-engineering job is done.

Value engineering is important to the electronics industry since it applies a forced organized approach to the reduction of the costs of all elements of the business. This is accomplished by taking a hard look at the individual element requirements and then determining first if the requirements are necessary, and second, how individual requirements

may be met to yield optimum cost. This is *not* an attempt to reduce cost by reducing performance, reliability, or quality. Investigations have indicated that successful value-engineering efforts not only reduce cost and schedule, but usually improve other characteristics as well.

In May 1964, The Department of Defense published a document entitled "Fringe Effects of Value Engineering" prepared by the special committee on value engineering of the American Ordnance Association. The report indicates that 44% of the 1961 changes investigated resulted in improvements in reliability while 1% did not; 40% improved and 2% decreased maintainability; 38% improved and none decreased quality; and 21% improved and 3% decreased performance. This is because successful value-engineering efforts usually simplify design, resulting in lower cost, increased quality and reliability, and improved maintainability

## Some Practical Examples

In each of the examples we will examine, the resultant new design reflects a careful investigation of each detail of the old design. In the first example shown in Fig. 1, the heavy steel plate used in the capacitor required expensive machining while the redesigned piece is turned out as a stamping. The soldered connection is replaced by an easily

Fig. 1. This capacitor was used by Lear Siegler's Power Equipment Division. The previous design resulted in a cost of \$11.22 each. After redesign, cost dropped to \$4.65 apiece, thereby resulting in total savings of \$6570 for every thousand produced.

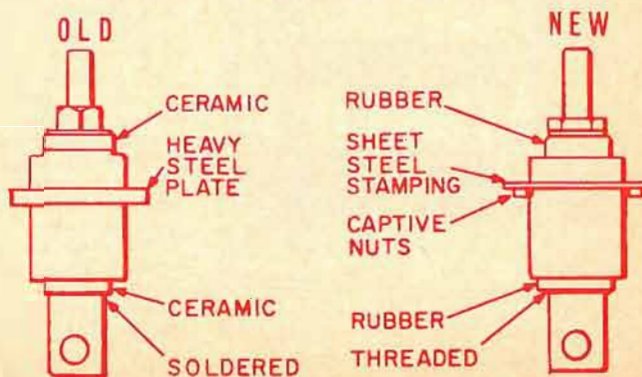



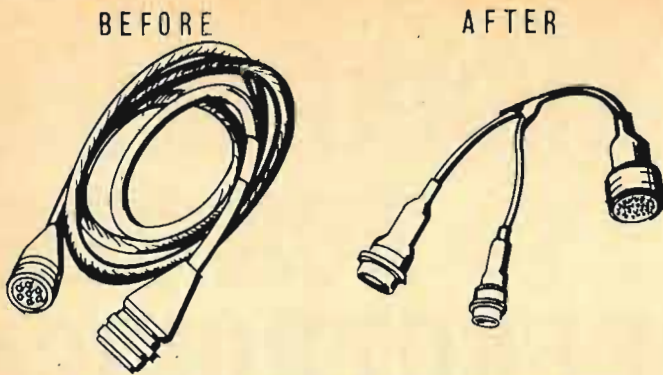

Fig. 2. Redesign of the molded-cable assembly used by General Electric Missile and Space Division. In the original design, custom molding was required and six types of cable assemblies were used. Typical costs for one type was \$250 each, for another type was \$940. After value analysis was used, the leads, breakouts, and connectors were assembled using oversized tubing, then heat-shrink tubing was used. Typical costs for each unit fell to \$100 and \$530 respectively. The total savings for manufacturer amounted to some \$111,000 per year.

produced and assembled threaded part while the relatively expensive ceramic parts, which were not required, were replaced by molded rubber parts.

Fig. 2 not only illustrates a cost saving obtained by replacing a custom-molded assembly with an easily made harness enclosed in heat-shrinkable tubing but also demonstrates the possibility of obtaining "fringe-effect" improvements. In this case there was improved quality control as well as ease of repair and modification.

Fig. 3 is an excellent example of value analysis as applied to a fabrication process. In this case the end product is the same, yet there is an appreciable annual saving. Individual spools of color-coded wire always present a problem in that they rarely come out even with the run or not enough of a given color is available when needed. In addition, when a small amount of a particular color-coded wire is required, it is necessary to obtain a whole spool. In-plant color coding of white wire provided the solution.

Fig. 4 illustrates the application of value analysis to a product that had been in use for some time. In this case the initial design was developed for a specific application and then adopted by a number of programs for other uses. The initial design permitted the handle, frame, and connector to be eliminated if desired. But this fact was forgotten from

the time of the initial design until the assembly's latest application. This example illustrates the im-

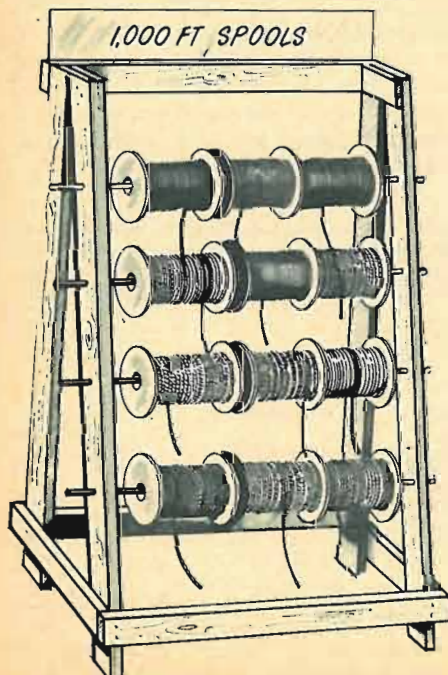

Fig. 3. The line drawing illustrates the previous method used by Lockheed Electronics Co. to dispense color-coded wire. In this case individual spools of color-coded wire were purchased from an outside vendor. In new method, shown in the photo, white wire is bought and up to three colors are applied by the in-plant machine to the exact lengths required for each job. This eliminated surplus and resulted in saving \$43,500/yr.

portance of continually reviewing products and designs even when they are acceptable and have been in use for a fairly long time.

Fig. 5 is still another example of a change in design which resulted in less costly fabrication techniques. The built-up sheet metal structure was replaced by a precision casting and the welded interconnections by a soldered printed-circuit board. This was done when a thorough analysis indicated that the change from welding to soldering was possible and that an increase in quantity allowed use of more expensive tooling. In smaller quantities, the sheet metal structure was less expensive and for other environments the welding was found necessary.

These five examples clearly indicate that there is no one way to solve a problem and what is an excellent solution at one time may be less than optimum at other times.

### Value Engineering Method

Value engineering developed as the result of discussions held some time prior to 1947 in the Purchasing Department at *General Electric*. The individuals involved recalled that during World War II it was necessary to locate substitutes for the required materials. Many times, it was discovered that the alternate proved far superior, both in cost and function, to the material that had been originally specified. Mr. Larry Miles, who is considered to be the "father of value engineering," was given the responsibility of developing this technique.

In the course of investigating the various techniques employed, it was found that the individuals most successful at it were those using *creative thinking*. If we review the usual texts on creative thinking or creative problem solving, we find that a seven-step procedure is involved: 1. orientation, 2. preparation, 3. analysis, 4. hypothesis, 5. incubation, 6. synthesis, and 7. verification.

These steps have been changed slightly by the value-engineering people and are referred to as the "job plan." Some companies use seven steps, some five. When five are used, the form becomes: 1. familiarization, 2. speculation, 3. analysis, 4. evaluation, and 5. implementation. The relation between the five steps of the job plan and the seven steps of creative problem solving is shown in Fig. 6.

1. *Familiarization*. During the familiarization phase all effort is concentrated on understanding and defining the required function. An attempt is made to define the primary function in two words: one a verb, the other a noun. In this way, one is forced to define the central purpose of the effort in unambiguous terms. During this phase, a solution is not attempted. This produces a problem-oriented rather than a solution-oriented attack. It also overcomes one of the greatest handicaps to problem solving—a misstatement of the problem.





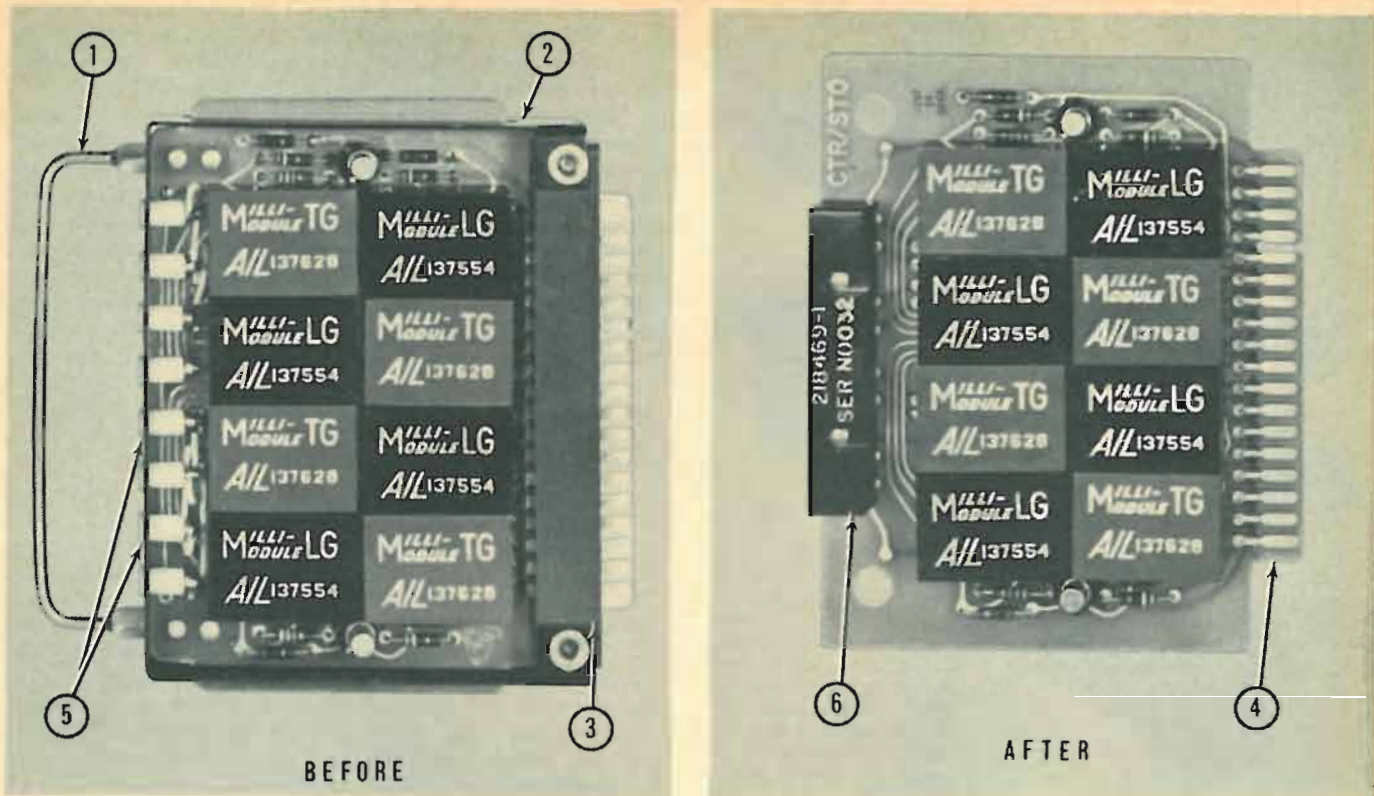

Fig. 4. Modifications in printed-circuit card assembly used by Airborne Instruments Laboratory. The photos show that the handle (1) and frame (2) were removed, the connector (3) was replaced with printed contacts (4), and the test points (5) were replaced with a flow-soldered test strip (6). These changes resulted in a total unit savings of \$85.25. The total quantity involved was 1200 units so that the total savings amounted to about \$102,000. The implementation cost for the newer version was \$20,000 for a total net savings of \$82,000.

2. *Speculation.* This step involves listing all possible solutions. An important characteristic of this step is the fact that no attempt is made to justify or criticize any of the suggested solutions. By not being critical of any of the solutions, freer thinking is encouraged. This is extremely effective when a number of individuals are involved and is very close to the technique of "brain-storming" which was popular with some industries a few years ago.

Included in this speculation phase is an "incubation" period. This is a time when the mind is allowed to concentrate on other matters with the solution to the primary problem coming as a "bolt from the blue".

3. *Analysis.* The analysis phase critically reviews the ideas generated during the speculation phase with a view to developing an optimum solution. Many times a number of possible solutions are advanced during this phase. The output of this phase is one or a limited number of complete solutions which are then evaluated.

4. *Evaluation.* During evaluation, the solution or solutions developed during the preceding phase are completely evaluated. Back-up data is collected or generated and a complete solution is documented. If a number of solutions are offered, these are ranked in some manner so that a final selection may be made.

5. *Implementation.* The "job plan" is set up so that a solution to the value problem may be found either by a team or by an individual. The individual may be a value expert working in a staff position or a design engineer authorized to make his own decisions. Implementation in this latter case is no problem. Implementation in the case of the value expert may present some problems so it is included as a discrete step in the plan. In this way, the entire effort is covered from investigation to solution.

Value engineering has embraced the whole subject of creative thinking and placed it in a new context. The success of the technique is due to its vigorous application and from forcing people to think toward a goal. In value engineer-

ing, this goal can be stated as *the least cost for a function.*

Value can mean prestige value, aesthetic value, resale value, or use value. We are interested in *use value.* Use value is the lowest cost that can be obtained while still providing the required function or service. Many times this is expressed as  $V = F/C$  where  $V$  is value,  $F$  is function, and  $C$  is cost. We are trying to obtain the greatest value for a given function and obtain this function for the least cost. "Least" is a relative term since in actuality we usually work to a definable or target cost.

The selling price of the equipment has been established by the time an engineer starts actual work on the project. Not only is the selling price established, but this total price has been prorated, as has the schedule, among individual segments of the company involved in producing the finished product. (This is demonstrated by the issuance of budgets and schedules to all departments involved before work is even started.)

Value engineering is a staff function which provides value information, assistance, and training to other departments. It is responsible for guidance and information—not direction. It provides a check and balance system for the cost characteristics of a design or procedure.

The relationship between the value engineer and the design engineer has been a matter of concern ever since the inception of value engineering. The degree of this concern involves the maturity of the organization and the type of business in which the company is involved. Where the company is predominantly development-oriented with a small production business, value engineering has had limited acceptance. Where the company is product-oriented with emphasis on production, value engineering has usually been well received.

In the first case, emphasis is placed on developing a product within a tight schedule and on a limited budget. In the second case, design for production involves a product which can be produced for a pre-determined cost. Addi-



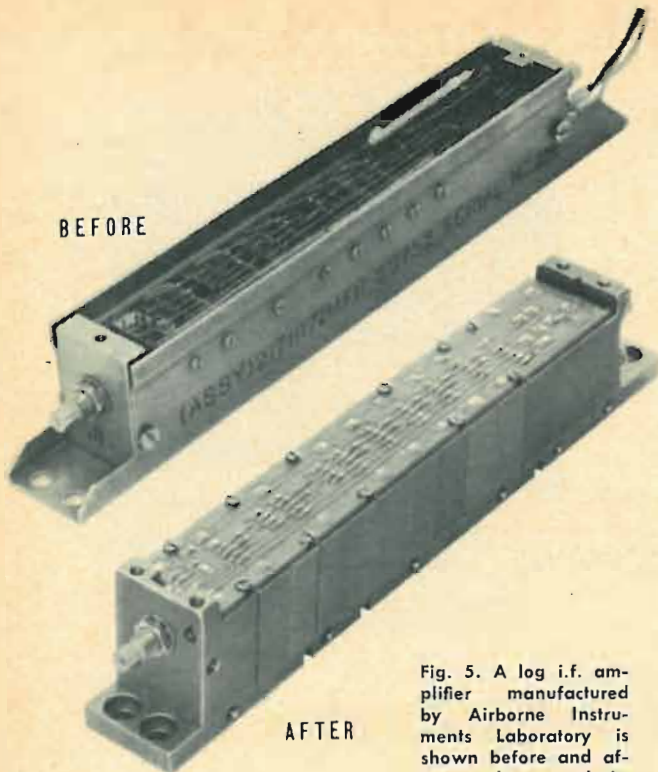

Fig. 5. A log i.f. amplifier manufactured by Airborne Instruments Laboratory is shown before and after value analysis.

The original version used built-up sheet metal construction and welded interconnections. The newer version used a cast casing and soldered printed-circuit board. There was a per-unit savings of \$50, resulting in a total savings of \$50,000 for a 1000-unit run. The implementation cost in this particular case amounted to about \$4500, resulting in \$45,000 net saving.

CREATIVE THINKING	VALUE ENGINEERING "JOB PLAN"
1. ORIENTATION	FAMILIARIZATION
2. PREPARATION	
3. ANALYSIS	
4. HYPOTHESIS	SPECULATION
5. INCUBATION	
6. SYNTHESIS	ANALYSIS
7. VERIFICATION	EVALUATION
	IMPLEMENTATION

Fig. 6. Relation between the seven steps of creative problem solving and the five steps of the value engineering job plan.

tional investment to achieve this goal can be amortized over a large production run. In this environment value engineering has thrived and the usefulness of the value engineer is very well understood and his services are fully utilized.

It is important to realize that value engineering cannot be utilized effectively on all projects or even within all companies. As the type of program or project approaches the research area, value engineering is of less use. This is because the cost of the hardware, procedures, or equipment is such

a small part of the project cost. As the cost of hardware, procedures, or equipment increases, however, the usefulness of and need for value engineering also increases.

Electronics organizations holding government contracts have acquired industrial "know how" over the past 20 years working on the relatively low-risk cost-plus-fixed-fee contracts. The usual measure of such an organization was its ability to solve problems within the schedule. Within broad limits, profit in terms of return on investment, didn't take into account how the work was done but whether or not the company could meet the contract deadline. With a change in both procurement policies and the competitive environment, the entire picture has changed. Not only is the profit potential greater but the risk of loss is greater. The vigorous application of value-engineering principles and philosophies is one of the most important shelters available to manufacturers in this new environment.

### Introducing Value Engineering

Introducing value engineering into an existing company framework is an extremely sensitive matter. If the company has a history and *modus operandi* for utilizing corporate or division staffs, this is an acceptable and useful organizational set up. If this prior acceptance and use has not been established, value engineering will have to be introduced in the department where it will receive maximum utilization. This will eliminate the problem of the "outsider." No matter how mature and intelligent department personnel may be, design assistance from outside groups is rarely accepted with enthusiasm.

Where value engineering personnel should be placed is also dependent on whether their primary function will be in value engineering or value analysis. If they will be concerned primarily with value engineering, they should work out of the product-engineering department.

On the other hand, if the primary activity is to be value analysis, personnel can be assigned on a much more flexible basis. In a company where the responsibility for product improvement rests with the original design group, value-analysis personnel should be attached to the product-engineering department. If some other department is responsible for product improvement, say, purchasing or manufacturing, the value-analysis group should be attached to that department.

Because value engineering is a relatively new "profession," some confusion exists as to the qualifications required of a value engineer. It is doubtful that such a man exists in "newly minted" form since one of the requirements is experience. He must have a broad background to enable him to understand the multiple facets of the problem and sufficient information regarding allied fields to seek the solution there if that is the answer. He must be mature enough to accept honest differences of opinion and senior enough to be respected for his views. These basic requirements can be met only after a number of years of experience—ten seems to be the minimum.

The requisite experience should be acquired in creative rather than analytical fields. In addition, special training in creative problem solving techniques will be required—usually *via* work-shop training seminars.

### The Department of Defense

The Department of Defense has always been an enthusiastic supporter of value engineering and continues to push the technique as a means of reducing costs. To this end, the Armed Service Procurement Regulations incorporate contract provisions for value engineering. These are of two types: one is called Value Engineering Program Requirements, the other Value Engineering Incentive Provisions. The Program Requirements define the value-engineering effort and specify the amount of effort to be expanded as an item of the contract. Cost reduc- (Continued on page 67)



# Musical Instrument Sound Chart

THE chart shown below indicates the audible frequency range of a variety of musical instruments. In most cases, the range indicates not only the instrument's fundamental frequency, but certain overtones that create the distinctive character of the instrument. In the case of the piano, note that the instrument keyboard goes to a lower fundamental frequency than is shown by the frequency range indicated

near the top of the chart. This is because the output at the lower piano notes are mainly harmonic in nature.

Not shown on the chart are the high-frequency noises that accompany many instruments to produce a certain amount of "color", *i.e.*, reed noise in the woodwinds, bowing noises in the stringed instruments, and key clicks and thumps of the piano and percussion instruments, etc. ▲

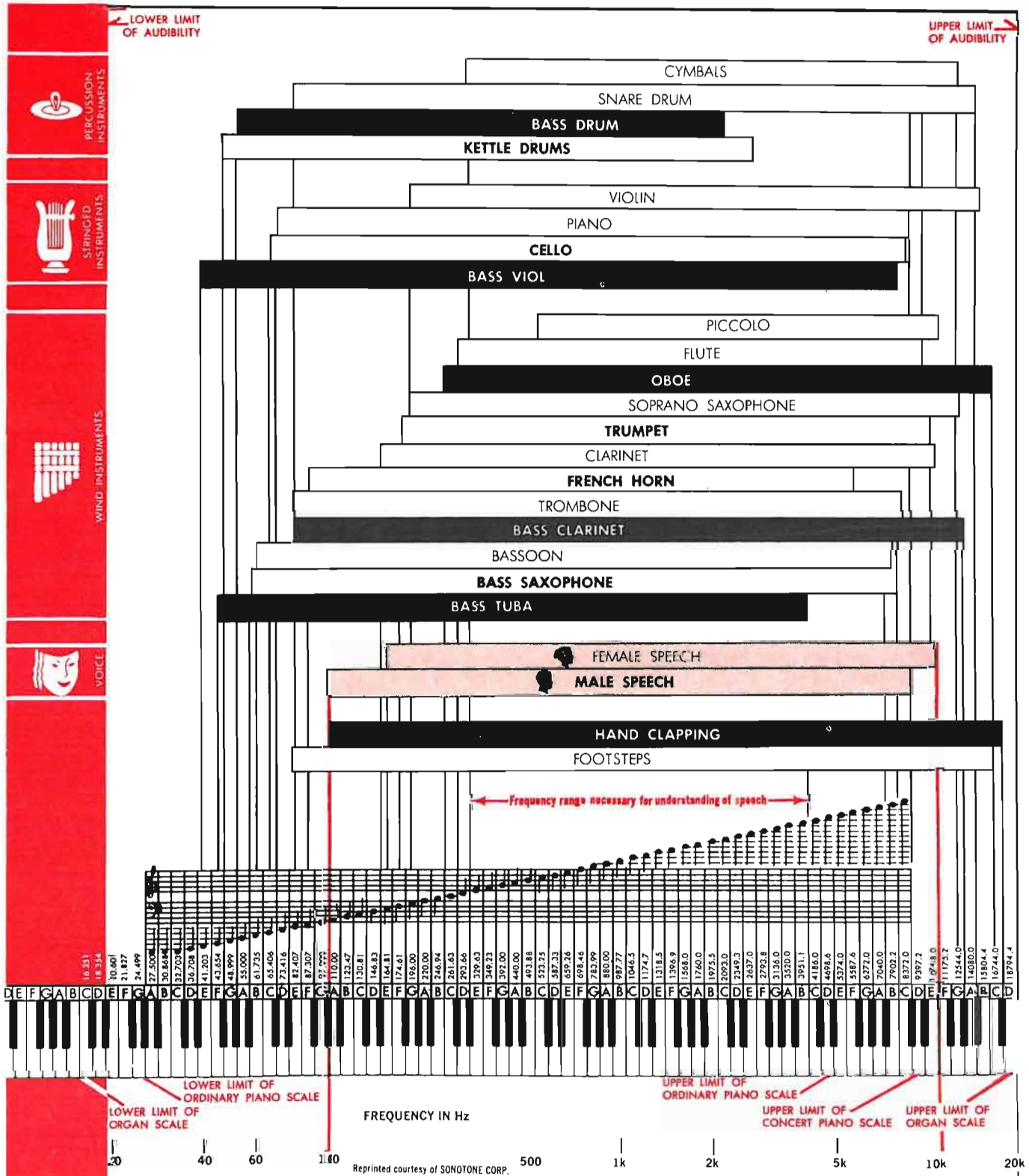



# DIGITAL COMPUTER LOGIC

## What the Symbols Mean

By ED BUKSTEIN/Northwestern Electronics Institute

*An explanation and comparison among the various types of logic circuits found in digital computers. Their circuit equivalents are also covered.*

**E**VEN the casual observer of the electronics scene has noted the increasing number of references in the technical literature to TTL, DTL, RTL, DCTL, etc. To what mysterious entities do these strange abbreviations allude? They are classifications of various types of digital logic circuits. Specifically, they indicate the types of components employed: diode-transistor logic (DTL), transistor-transistor logic (TTL), resistor-transistor logic (RTL), and so on.

Digital computers operate in the binary number system, and this system employs only two kinds of digits: *zeros* and *ones*. Logic circuits are therefore designed to recognize only two different levels of voltage, as selected by the designer. Five volts and ground, for example, may be chosen to represent binary 1 and binary 0, respectively. Another designer, for reasons of his own, may select  $-10$  and  $+10$  volts to represent the binary ones and zeros.

### Logic Blocks

The basic logic blocks are shown in Fig. 1. As indicated, an *and* gate is an all-or-nothing type of circuit. Its output terminal will be at the binary 1 voltage level only when *all* of its input terminals are at the binary 1 level. The *and* gate can be designed to have many input terminals (instead of only two as shown in Fig. 1), but it will still require *all* binary 1 inputs to produce a binary 1 output. Essentially this gate is the equivalent of a number of switches in series. Each one must be closed for the external circuit to operate.

The *or* gate produces a binary 1 output when at least one of its input terminals is at the binary 1 voltage level. The *or* gate can also be designed to have many input terminals instead of only the two shown. Essentially this gate is the equivalent of a number of parallel-connected switches; therefore, only one must be closed for the external circuit to operate.

The inverter circuit, also known as a *not* circuit, produces a binary 1 output only when its input is at the binary 0 voltage level. This circuit is essentially a phase-reversing one-stage amplifier. Because of this inversion characteristic, the output voltage level is high when the input is low, and *vice versa*.

An *or* gate can be fabricated using only passive elements such as resistors and diodes. These elements, however, provide no gain, and the binary voltage levels must therefore be re-established after several cascaded logic stages. Also, the passive elements have very little fan-out capability (the ability to provide sufficient output current to simultaneously drive a number of other logic gates). For these reasons, the *or* gate is often used in conjunction with an amplifier stage (inverter). The combination is known as a *nor* gate. Similarly, the *and* gate is used in conjunction with an inverter, and the combination is known as a *nand* gate.

*Nor* and *nand* gates are illustrated in Fig. 2. Note that the *nor* gate produces a binary 1 output only when all input terminals are at the binary 0 voltage level. The *nand* gate produces a binary 0 output only when all inputs are binary 1.

High-speed operation is one of the most desirable features of a logic circuit. Propagation delay (a measure of the ability of the output level to change rapidly in response to a change in input level) should be extremely short because this delay limits the rate at which a computer can process data. Values of propagation delay in the range of 10 to 100 nanoseconds are common. Speed, however, is not the only desirable characteristic and must sometimes be sacrificed in favor of other factors.

In addition to speed, the following features are highly desirable in logic circuits: *noise immunity* so that the logic circuit will not respond to stray pulses; *low-power dissipation* per logic stage to minimize temperature and power-supply problems when thousands of these stages are combined in a computer; high *fan-in* and *fan-out* capability so that each logic stage can be controlled by many others and can, in turn, control a large number of other stages. Ideally, the circuit should also be easy to manufacture and should not be critical with respect to transistor characteristics. Most of these desirable features are trade-offs, and the engineer can achieve improvements in one by making sacrifices in another. The final design is therefore a compromise

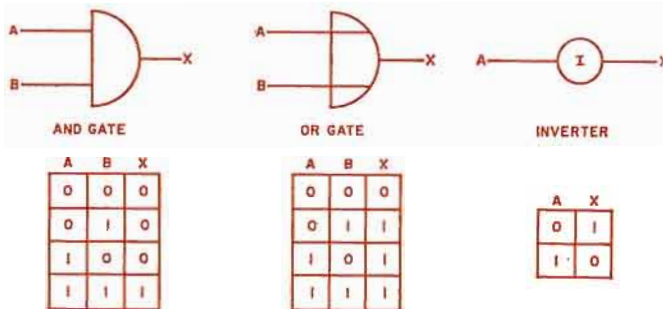

Fig. 1. Basic logic blocks with truth tables. Circuits are not drawn, but standard symbols are used instead.

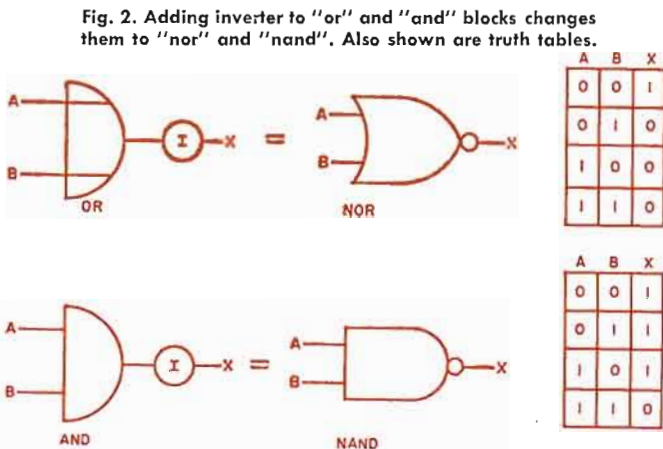

Fig. 2. Adding inverter to "or" and "and" blocks changes them to "nor" and "nand". Also shown are truth tables.



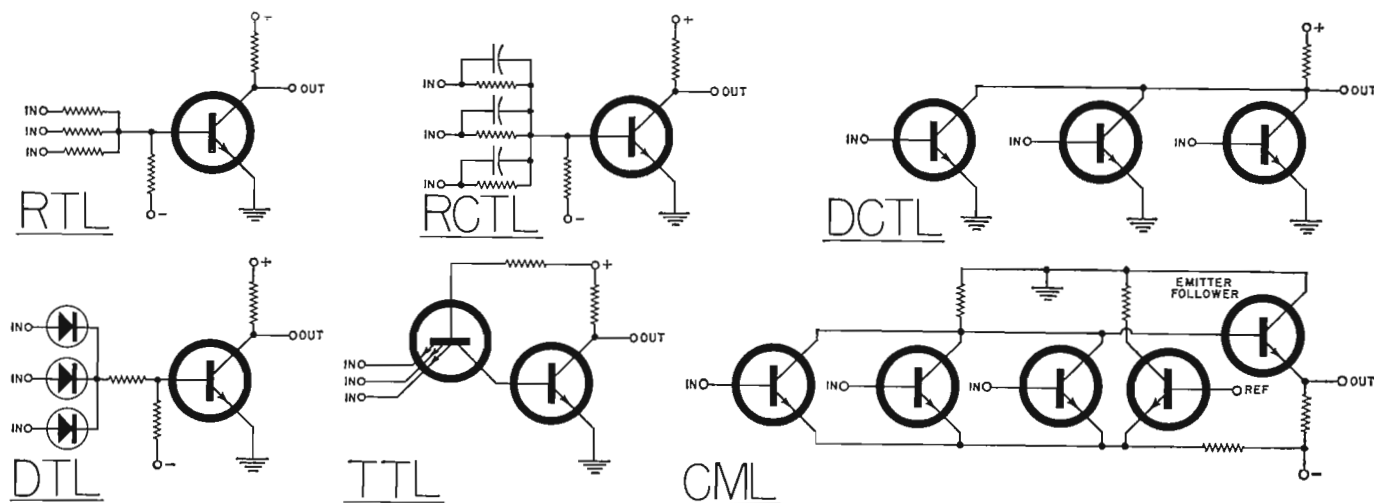

Fig. 3. Circuit diagrams of six common types of logic elements as employed widely in digital computers.

among a number of highly desirable but conflicting characteristics.

### Definitions

The six most common types of logic circuits are illustrated in Fig. 3 and are described as follows.

RTL (resistor-transistor logic) has the advantages of simplicity and low cost. It is easy to manufacture and, because transistor parameters are not critical in this circuit, it is highly reliable. RTL is not suited to high-speed applications, and fan-in and fan-out are relatively limited. When these requirements are not stringent, RTL is popular.

In the circuit shown, the  $n$ - $p$ - $n$  transistor is biased off by the negative supply voltage to its base. If a positive input is now applied to any one or more of the input terminals, the transistor will turn on and the output voltage will drop almost to ground level. If a positive voltage then represents binary 1 and ground now represents binary 0, this is a *nor* circuit; when all inputs are binary 0 (ground), the transistor will be off and the output level will be binary 1 (positive).

It is of interest to note that if the definition of the logic levels is reversed, this same circuit will function as a *nand*. If the positive voltage level represents the binary 0 and ground now represents binary 1, the *nand* action is as follows: all inputs must be binary 1 (ground) in order for the output level to be binary 0 (positive).

This *nor*/*nand* characteristic is true not only of RTL but also of all other types of logic circuits. If the more positive of the two voltage levels represents the binary 1, the circuit functions one way; if the more negative of the two levels then represents binary 1, the circuit functions the other way. A positive *nor* is therefore equivalent to a negative *nand*, and *vice versa*.

RCTL (resistor-capacitor-transistor logic) is similar to RTL except that capacitors are bridged across the input resistors. These "speed-up" capacitors permit faster turn on of the transistor in response to a change in input and also help overcome the storage delay of the transistor itself. The increase in circuit speed is achieved at the expense of additional components.

DCTL (direct-coupled transistor logic) is faster than the RTL type but requires tighter specifications on the transistors. It also requires more transistors for a given number of input terminals. DCTL can be made less critical with respect to transistor characteristics by adding a resistor in series with each input terminal, but this will decrease speed and add to cost. In the circuit shown, a positive input to any one (or more) of the input terminals will turn on the transistor (or transistors), and the output level will drop practically to ground. The output level will be positive only when no positive inputs are applied. If the positive level

represents the binary 1, the circuit performs the *nor* function; if ground is binary 1, the circuit is a *nand*.

DTL (diode-transistor logic) is faster than either RTL or DCTL. Because of its higher speed and because the isolation of the diodes permits higher fan-in and fan-out, DTL is extremely popular. For the circuit shown, a positive input to any one (or more) of the input terminals will turn on the transistor, and the output will drop to ground level. Only when the circuit receives no inputs (all input terminals at ground level) will the output be at the positive logic level.

TTL (transistor-transistor logic) is a product of integrated-circuit technology (in which multiple emitters can be fabricated rather easily). In the basic circuit shown in Fig. 3, the input emitters can be regarded as the cathodes of three diodes, and the base can be considered as the common anode for these diodes. If any one (or more) of the input emitters is grounded, the corresponding diode (or diodes) will conduct. Practically all of the supply voltage is now dropped across the base resistor of the first transistor, cutting off the second transistor. The output is therefore at a positive level. Only when all input emitters are driven positive will the output transistor conduct, allowing the output level to drop to ground. TTL, also referred to as  $T^2L$ , has excellent speed capabilities. Propagation delays down to about 5 nanoseconds have been achieved, making this faster than any of the other logic types previously described.

CML (current-mode logic) is the fastest of the logic types; propagation delays below 5 nanoseconds have been achieved, and fractional-nanosecond delays are in sight. Offsetting this speed advantage, however, is the relatively large number of components required (and the corresponding increase in power dissipation). The high speed of this type of logic is achieved by preventing the input transistors from going into saturation.

The input transistors are biased by a voltage drop across a common-emitter resistor, and this drop is controlled by another transistor responding to a reference voltage. The reference voltage is selected so that the input transistors are biased midway between the two levels representing the binary 1 and binary 0. Only the more positive (less negative) of the two levels will therefore be capable of turning on an input transistor, driving the collector to a negative logic level. The value of the collector resistor is also selected to prevent saturation of the input transistors. The collectors are coupled through an emitter-follower stage to the output terminal. For this reason, this type of circuit is sometimes referred to as ECL (emitter-coupled logic). The low output impedance of the emitter-follower permits high fan-out and short rise time even for capacitive loads.

(Editor's Note: Many of the logic circuits covered in this article are available in integrated form.) ▲



# Universal Wiring for Automotive Ignition Systems

By CHARLES C. MORRIS

*One master terminal strip enables rapid connection of various types of electronic ignition systems, yet easy return to the original circuit.*

WITH the availability of transistor and the capacitor-discharge ignition systems, many experimenters have tested various circuits in their automobiles. The primary purpose, of course, is to compare the performance of the different electronic versions with each other and with the conventional system. One major drawback that prevents more experimentation in this area is the necessity of constant rewiring or retracing of existing wiring to adapt to various circuits. On many systems this can be time-consuming and discouraging.

To ease this testing procedure, it would be beneficial if all the pertinent circuits were available at one common, easily accessible point in the engine compartment. Even better, if all these points were connected to one master terminal board.

The circuitry shown in Fig. 1 is one way of creating a universal external wiring location that eliminates the need for constant rewiring of ignition-system

components. It is simple in that all of the basic component leads and power leads are brought out to a common terminal strip and matching connector strips used to couple the components together. Once wired and installed, a multitude of circuits can be tried by using proper matching to TS1. All wires needed for any installation are now terminated in a central location. A screw-type terminal strip was used since there might be a desire to rearrange certain wires on the terminal strip. Plug-in types of terminals usually involve soldering and therefore limit versatility, although they could be used.

Troubleshooting is also easier, since key voltage and current tests can be made at TS1 rather than at other points which might involve disconnecting solder or plug joints. Also note that TS2 is wired to restore the system to conventional operation should the electronic system suffer a failure. The conventional distributor capacitor (C1) is connected to TS2 since it is not often used with electronic ignition circuits and does not

have to be mounted inside the distributor housing.

Installation of TS1 should be in a central location with respect to ignition-system components. This limits excessive lead length and thus cuts down on losses. A preferable location would be on the firewall. Any special ignition coils could also be permanently mounted near the distributor since many of these coils are universal in that they can be used with a number of transistorized ignition circuits.

As with any installation, extremely good grounds must be made consisting of tight metal-to-metal contact. Grounds should be made between the electronic ignition circuit ground and the automobile. Another ground should be made between the firewall and engine block if it is not already present. Terminal 2 of TS1 and the negative side of the special transistorized ignition coil are also connected to the automobile electrical ground. Heavy braid wire is good for making ground connections, while other external wiring may be made with #12 or #14 600-volt insulated wire. The voltage rating is made high since some wiring is used for capacitor-discharge circuits which deliver up to 400 volts or so to the ignition coil. For this reason, the primary wires on the conventional ignition coil should also be rated for 600 volts, since many capacitor-discharge circuits use the conventional coil.

The ballast resistor used on many 12-volt automobiles usually consists of either a ceramic body resistor or a resistive wire built into the wiring harness. However, these resistors usually do not terminate directly on the coil or ignition switch contacts so that the 12-volt wire going to terminal 8 of TS1 can be connected easily. The ideal place would be directly on the ignition switch terminal, or as close as possible. For the wire on terminal 7 of TS1, including the ballast resistor, simply use the original wire going to the battery or positive terminal on the conventional ignition coil. Positive-ground installation can easily be made with this circuitry, depending upon the automobile involved—simply wire the terminal assemblies using proper polarity.

This method of universal wiring will permit rapid installation of numerous circuits, since all components necessary will be found in a central location. ▲

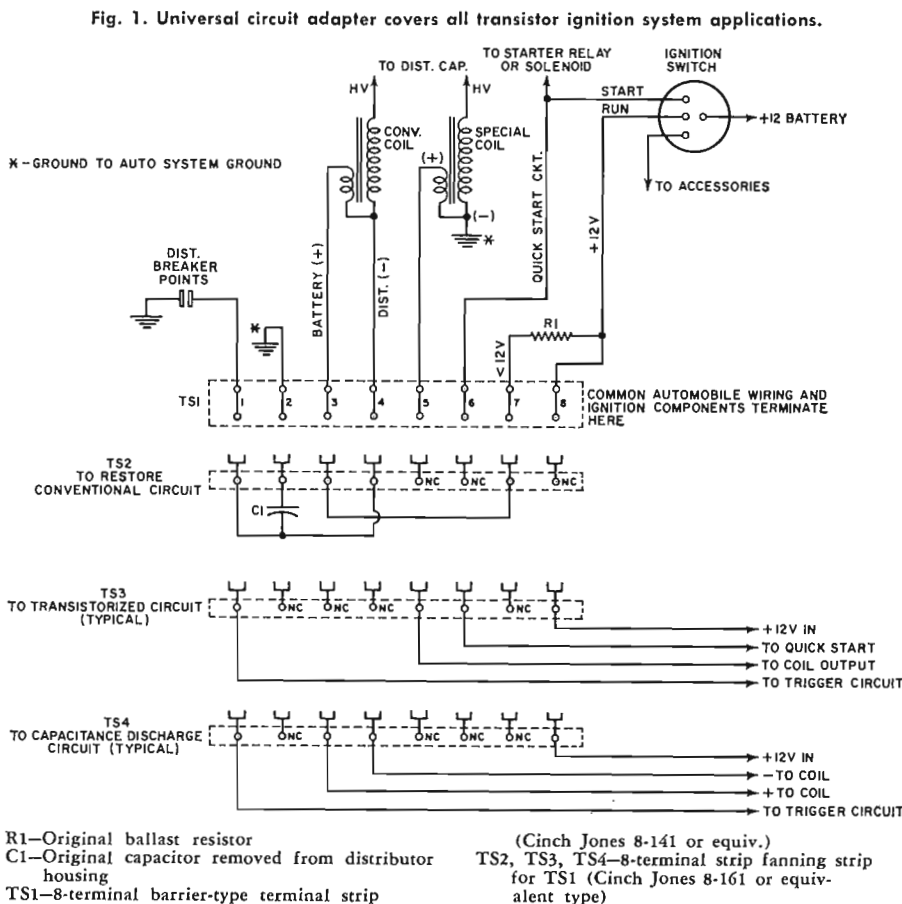



# THE OPERATIONAL AMPLIFIER

## Circuits & Applications

By DONALD E. LANCASTER

*These highly versatile controllable-gain modular or integrated-circuit packages have been used in computer and military circuits. New price and size reductions have opened commercial and consumer markets. Here are complete details on what is available and how the devices are used.*

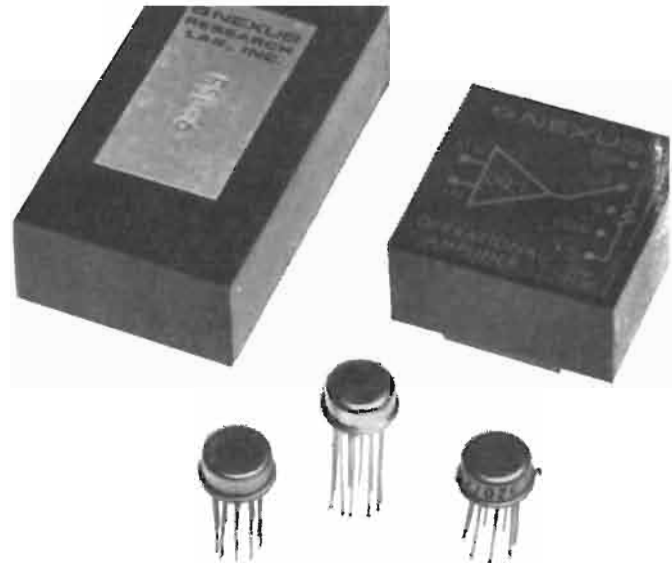

Typical modular package and TO-5 style IC operational amplifiers.

ONCE exclusively the mainstay of the analog-computer field, operational amplifiers are now finding diverse uses throughout the rest of the electronics industry. An operational amplifier is basically a high-gain, d.c.-coupled bipolar amplifier, usually featuring a high input impedance and a low output impedance. Its inherent utility lies in its ability to have its gain and response precisely controlled by external resistors and capacitors.

Since resistors and capacitors are passive elements, there is very little problem keeping the gain and circuit response stable and independent of temperature, supply variations, or changes in gain of the op amp itself. Just how these resistors and capacitors are arranged determines exactly what the operational amplifier will do. In essence, an op amp provides "instant gain" that may be used for practically any circuit from a.c., d.c., and r.f. amplifiers, to precision waveform generators, to high-"Q" inductorless filters, to mathematical problem solvers.

Op amps used to be quite expensive, but many of today's integrated circuit versions now range from \$6 to \$20 each and less in quantity. Due to price breaks that have occurred very recently, the same benefits now available to the analog computer, industrial, and military markets are now extended to commercial and consumer circuits. One obvious application will be in hi-fi preamps where a single integrated circuit can replace the bulk of the low-level transistor circuitry normally used.

Fig. 1A shows the op-amp symbol. An op amp has two high-impedance inputs, the *inverting input* and the *non-inverting input*, as indicated by a "-" or a "+" on the input side of the amplifier. The inverting input is out-of-phase with the output, while the non-inverting input is in-phase with the output. The amplifier has an open-loop gain  $A$ , which may range from several thousand to several million.

On closer inspection, we see three distinct parts to any operational amplifier's internal circuitry, as shown in Fig. 1B. A high-input-impedance differential amplifier forms the first stage, with the inverting input going to one side and the non-inverting input the other. The purpose of this stage is to allow the inputs to differentially drive the circuit and also to provide a high input impedance.

There are several possibilities for this input stage. If an ordinary matched pair of transistors (or the integrated-circuit equivalent) is used, an input impedance from 10,000

to 100,000 ohms will result, combined with low drift, low cost, and wide bandwidth. By using four transistors in a differential Darlington configuration, the input impedance may be nearly one megohm. Drift and circuit cost are traded for this benefit.

Field-effect transistors are sometimes used, yielding input impedances of 100 megohms, but often with limited bandwidths. FET integrated-circuit operational amplifiers are not yet available, limiting this technique to the modular-style package at present. One or two novel techniques allow extreme input impedances, but presently at very high cost. One approach is to use MOS transistors with their  $10^{13}$ -ohm input impedance; a second is to use a varactor diode parametric amplifier arrangement on the input.

The input differential amplifier is followed by ordinary voltage-gain stages, designed to bring the total voltage gain up to a very high value. Terminals are usually brought out of the voltage-gain stage to allow the frequency and phase response of the op amp to be tailored for special applications. This is usually done by adding external resistors and capacitors to these terminals.

Since an operational amplifier is bipolar, the output can swing either positive or negative with respect to ground. A dual power-supply system, one negative and one positive, is required.

The final op-amp stage is a low-impedance power-output stage, which may take the form of a single emitter-follower, a push-pull emitter-follower, or a class-B power stage. This final circuit serves to make the output loading and the over-all gain and frequency response independent. It also provides a useful level of output power.

Fig. 1. (A) Op-amp symbol. (B) Block diagram of typical op amp.

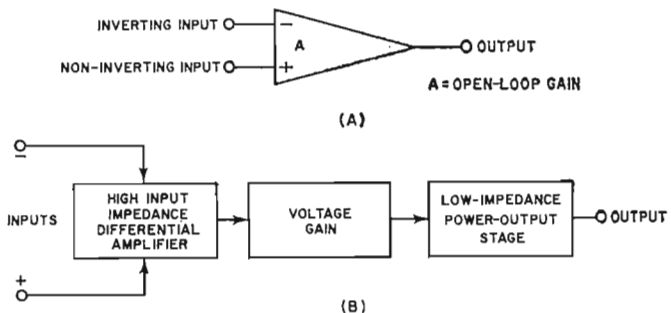







categories: the industrial circuits, the computer circuits, and the active network synthesis circuits. The industrial circuits are "ordinary" ones, which will carry over into the consumer and commercial fields with little change.

The boxed copy (facing page) sums up the mathematics. An operational amplifier is often used in conjunction with two passive networks, an *input* network, and a *feedback* network, both of which are normally connected to the inverting input. The gain of the over-all circuit at any frequency is given by the equation shown. It is simply the ratio of the feedback impedance to the input impedance at that frequency. For the circuits shown, a low impedance path to ground must exist for all input sources to allow a return path for base current in the two input transistors.

Fig. 5A shows an inverting gain-of-100 amplifier useful from d.c. to several hundred kHz. The basic equation tells us the gain will be  $-10,000/100 = -100$ . The 100-ohm resistor on the "+" input provides base current for the "+" transistor and does not directly enter into the gain equation. It may be adjusted to obtain a desired drift or offset characteristic.

The higher the gain of the op amp, the closer the circuit performance will be to the calculated performance. In the gain-of-100 amplifier, if the op amp gain is 1000, the gain error will be roughly 1%. The exact value of the gain also depends upon the precision to which the input and feedback components are selected.

Choosing different ratios of input and feedback impedances gives us different gains. Fig. 5B shows a gain-of-10 amplifier with a d.c. to 2 MHz frequency response and a 1000-ohm input impedance.

We might ask at this point what we gain by using an op amp in this circuit instead of an ordinary single transistor circuit. There are several important answers. The first is that the input and output are *both* referenced to ground. Put in zero volts and you get out zero volts. Put in -400 millivolts and you get out +4 volts. Put in 400 millivolts and you get out -4 volts. Secondly, the output impedance is very low and the gain will not change if you change the load the op amp is driving, as long as the loading is light compared to the op amp's output impedance. Finally, the gain is precisely 10, to the accuracy you can select the input and feedback resistors, independent of temperature and power-supply variations. It is this precision and ease of control that makes the operational amplifier configuration far superior to simpler circuitry.

If the output is connected to the "-" input and an input directly drives the "+" input, the unity-gain voltage follower of Fig. 5C results. This configuration is useful for following precision voltage references or other voltage sources that may not be heavily loaded. The circuit is superior to an ordinary emitter-follower in that the offset is only a millivolt or so instead of the temperature-dependent 0.6-volt drop normally encountered, and the gain is truly unity and not dependent upon the *alpha* of the transistor used.

Table 1. Comparison between integrated operational amplifiers and modular-type operational amplifiers.

	INTEGRATED OP AMP	MODULAR OP AMP
<b>COST</b>	(+) Can be quite low. Quality units cost \$6 to \$50 each.	(-) Inherently more expensive. Ranges from \$14 economy units to \$1000 each.
<b>SIZE</b>	(+) Very small. Usually a TO-5 can, in-line epoxy, or flat pack.	(-) Black epoxy modules usually measure a few cubic inches. May be bulky if used in quantity.
<b>GAIN</b>	(-) Low. Typical units have gains from 1000 to 30,000	(+) Gain may go extremely high in premium units.
<b>INPUT IMPEDANCE</b>	(-) Low. 7000 to 100,000 ohms is typical with newer premium units approaching one megohm.	(+) High. Premium units using FET's or parametric varactor systems offer input impedances of hundreds of megohms.
<b>INPUT OFFSET &amp; DRIFT</b>	(+) Very low. Integrated circuitry yields matched input transistors with excellent temperature performance. Drift of a few microvolts per degree C is typical.	(-) Much higher unless specially selected components or external stabilization is used.
<b>AVAILABLE OUTPUT</b>	(-) Limited to 250 milliwatts internal dissipation. 10 volts peak-to-peak output typical; 26 volts p-p in one premium unit.	(+) Package is not dissipation limited. Substantial output power levels and voltage swings readily obtainable in special units.

<b>ANALOG DEVICES INC.</b> 221 Fifth Avenue Cambridge, Mass. 02142	<b>K &amp; M ELECTRONICS CORP.</b> 102 Hobart Street Hackensack, N.J.
<b>BURR BROWN RESEARCH</b> International Airport Industrial Pk., Box 11400 Tucson, Ariz. 85706	<b>KEITHLY INSTRUMENTS</b> 12415 Euclid Avenue Cleveland, Ohio 44106
<b>COMPUTER DYNAMICS</b> 179 Water Street Torrington, Conn. 06790	<b>NEXUS RESEARCH LABORATORY, INC.</b> 480 Neponset Street Canton, Mass. 02021
<b>DATA DEVICE CORP.</b> 240 Old Country Road Hicksville, N.Y. 11810	<b>PHILBRICK RESEARCHES</b> 17 Allied Drive at Rte. 128 Dedham, Mass. 02026
<b>HAMILTON STANDARD DIV.</b> United Aircraft Company Broad Brook, Conn. 06016	<b>UNION CARBIDE ELECTRONICS</b> 365 Middlefield Road Mountain View, Cal. 94041
<b>ZEI TEX INC., 1500 Chalomar Rd., Concord, California</b>	

Table 2. Listing of modular-type operational-amp manufacturers.

<b>AMELCO SEMICONDUCTOR</b> Box 1030 Mountain View, Cal. 94042	<b>PHILBRICK RESEARCHES</b> 17 Allied Drive at Rte. 128 Dedham, Mass. 02026
<b>FAIRCHILD</b> 313 Fairchild Drive Mountain View, Cal. 94040	<b>RCA ELECTRONIC COMPONENTS &amp; DEVICES</b> 415 South 5th St. Harrison, N.J. 07029
<b>GENERAL ELECTRIC CO.</b> Semiconductor Products Dept. Electronics Park Syracuse, N.Y. 13201	<b>RADIATION INC.</b> Box 220 Melbourne, Fla. 32902
<b>GENERAL INSTRUMENTS</b> 600 W. Johns Street Hicksville, N.Y.	<b>SIGNETICS CORP.</b> 811 East Arques Ave. Sunnyvale, Cal. 94086
<b>MOTOROLA SEMI-CONDUCTOR PRODUCTS</b> Box 955 Phoenix, Ariz. 85001	<b>TEXAS INSTRUMENTS</b> P.O. Box 5012 Dallas, Tex. 75080
<b>NATIONAL SEMI-CONDUCTOR</b> Box 443 Danbury, Conn. 06813	<b>WESTINGHOUSE MOLECULAR ELECTRONICS</b> Box 7737 Elkridge, Md. 21227

Table 3. Listing of integrated-circuit op-amp manufacturers.

By making the gain of the op amp frequency-dependent, various filter configurations are realized. For instance, Fig. 5D shows a band-stop amplifier. For very low and very high frequencies, the series *RLC* circuit in the feedback network will be a very high impedance and the gain will be  $-10,000/1000 = -10$ . At resonance, the series *RLC* impedance will be 100 ohms and the gain will be  $-100/1000 = -0.1$ . The gain drops by a factor of 100:1 or 40 decibels at the resonant frequency. The selection of the *LC* ratio will determine bandwidth, while the *LC* product will determine the resonant frequency.

Fig. 5E does the opposite, producing a response peak at resonance 100 times higher than the response at very high or very low frequencies, owing to the very high impedance at resonance of a parallel *LC* circuit. More complex filter structures may be used to obtain any reasonable filter func-



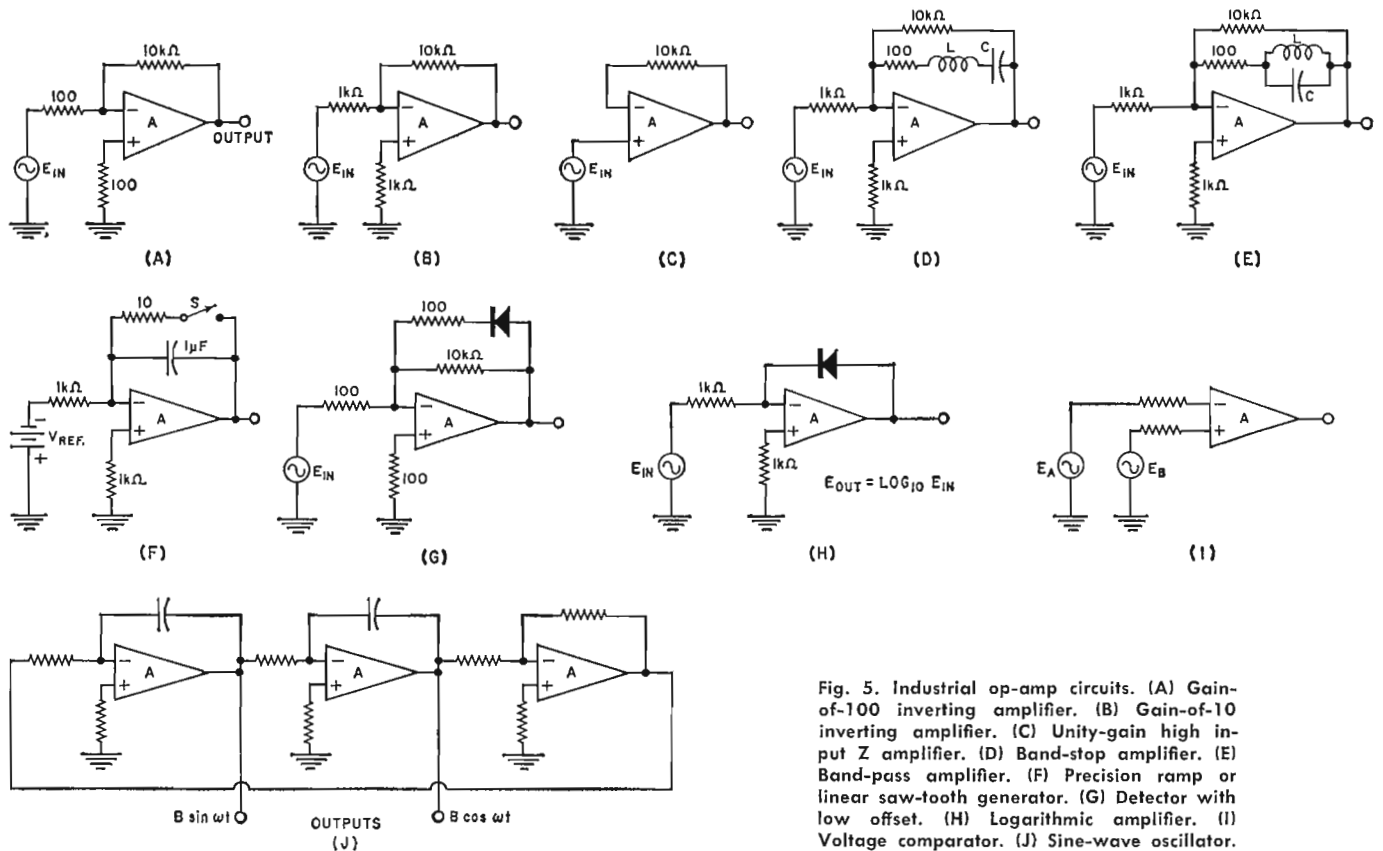

Fig. 5. Industrial op-amp circuits. (A) Gain-of-100 inverting amplifier. (B) Gain-of-10 inverting amplifier. (C) Unity-gain high input Z amplifier. (D) Band-stop amplifier. (E) Band-pass amplifier. (F) Precision ramp or linear saw-tooth generator. (G) Detector with low offset. (H) Logarithmic amplifier. (I) Voltage comparator. (J) Sine-wave oscillator.

tion or response curve. Audio equalization curves are readily realized using similar techniques.

Turning to some different applications, Fig. 5F shows a precision ramp generator. Operation is based upon the current source formed by the reference voltage and 1000-ohm resistor on the input. In any op-amp circuit, the current that is fed back to the input must equal the input current, for otherwise the “-” input will have a voltage on it, which would immediately be amplified, making the input and feedback currents equal.

A constant current to a capacitor linearly charges that capacitor, producing a linear voltage ramp. The slope of the ramp will be determined by the current and the capacitance, while the linearity will be determined by the gain of the op amp. A sweep of 0.1-percent linearity is easily achieved. The output ramp is reset to zero by the switch and the 10-ohm current-limiting resistor. For synchronization, S may be replaced by a gating transistor. A negative input current produces a positive voltage ramp at the output. Note that the sweep linearity and amplitude is independent of the output loading as long as the load impedance is higher than the output impedance of the op amp. Ramps like this are often used in CRT sweep waveform generation, analog-to-digital converters, and similar circuitry.

Silicon diodes normally have a 0.6-volt offset that makes them unattractive for detecting very low signal levels. If a diode is included in the feedback path of an operational amplifier, this offset may be reduced by the gain of the circuit, allowing low-level detection. Fig. 5G is typical. Here the gain to negative input signals is equal to unity, while the gain to positive input signals is equal to 100. The diode threshold will be reduced to 0.6 volt/100 = 6 millivolts.

Another diode op-amp circuit is that of Fig. 5H. Here the logarithmic voltage-current relation present in a diode makes the feedback impedance decrease with increasing input signals, reducing the circuit gain as the input current increases. The net result is an output voltage that is proportional to the *logarithm* of the input, and the circuit is a logarithmic amplifier. This configuration only works on

negative-going inputs and is useful in compressing signals, measuring decibels, and in electronic multiplier circuits where the logarithms of two input signals are added together to perform multiplication.

An operational amplifier is rarely run “wide open”, but Fig. 5I is one exception. Here the op amp serves as a voltage comparator. If the voltage on the “-” input exceeds the “+” input voltage, the op amp output will swing as negative as the supply will let it, and *vice versa*. A difference of only a few millivolts between inputs will shift the output from one supply limit to the other. Feedback may be added to increase speed and produce a snap action. One input is often returned to a reference voltage, producing an alarm or a limit detector.

Op amps may also be used in groups. One example is the low-distortion sine-wave oscillator of Fig. 5J, in which three op amps generate a precision sine wave. Both sine and cosine outputs, differing in phase by 90° are produced. An external amplitude stabilization circuit is required, but not shown. Output frequency is determined solely by resistor and capacitor values and their stability.

### Computer Circuits

The analog computer industry was the birthplace and once the only home of the operational amplifier. In fact the name comes from the use of op amps to perform mathematical *operations*. Many of these circuits are of industry-wide interest and use.

Perhaps the simplest op-amp circuit is the inverter. This is an op amp with identical input and feedback resistors. Whatever signal gets fed in, minus that signal appears at the output, thus performing the sign-changing operation.

Addition is performed by the circuit of Fig. 6A. Here the currents from inputs  $E_1, E_2$ , and  $E_3$  are summed and the negative of their sum appears at the output. Since the negative input is always very near ground because of feedback, there is no interaction among the three sources. Resistor R is adjusted to obtain the desired drift performance.

By shifting the resistor values around, the basic summing





## Why We Make the Model 211 Available Now

Although there are many stereo test records on the market today, most critical checks on existing test records have to be made with expensive test equipment.

Realizing this, HiFi STEREO REVIEW decided to produce a record that allows you to check your stereo rig, accurately and completely, just by listening! A record that would be precise enough for technicians to use in the laboratory—and versatile enough for you to use in your home.

The result: the HiFi STEREO REVIEW Model 211 Stereo Test Record!

## Stereo Checks That Can Be Made With the Model 211

- ✓ Frequency response—a direct check of eighteen sections of the frequency spectrum, from 20 to 20,000 cps.
- ✓ Pickup tracking—the most sensitive tests ever available on disc for checking cartridge, stylus, and tone arm.
- ✓ Hum and rumble—foolproof tests that help you evaluate the actual audible levels of rumble and hum in your system.
- ✓ Flutter—a test to check whether your turntable's flutter is low, moderate, or high.
- ✓ Channel balance—two white-noise signals that allow you to match your system's stereo channels for level and tonal characteristics.
- ✓ Separation—an ingenious means of checking the stereo separation at seven different parts of the musical spectrum—from mid-bass to high treble.

**ALSO:** ✓ Stereo Spread  
Speaker Phasing  
Channel Identification

## PLUS SUPER FIDELITY MUSIC!

The non-test side of this record consists of music recorded directly on the master disc, without going through the usual tape process. It's a superb demonstration of flawless recording technique. A demonstration that will amaze and entertain you and your friends.

# NOW...GET THE FINEST STEREO TEST RECORD ever produced

for just...\$4.98

## Featuring Tests Never Before Available Outside Of The Laboratory

### UNIQUE FEATURES OF HiFi/STEREO REVIEW'S MODEL 211 STEREO TEST RECORD

- Warble tones to minimize the distorting effects of room acoustics when making frequency-response checks.

*Warble tones used are recorded to the same level within  $\pm 1$  db from 40 to 20,000 cps, and within  $\pm 3$  db to 20 cps. For the first time you can measure the frequency response of a system without an anechoic chamber. The frequency limits of each warble are within 5% accuracy.*

- White-noise signals to allow the stereo channels to be matched in level and in tonal characteristics.
- Four specially designed tests to check distortion in stereo cartridges.
- Open-air recording of moving snare drums to minimize reverberation when checking stereo spread.

## All Tests Can Be Made By Ear

HiFi STEREO REVIEW's Model 211 Stereo Test Record will give you immediate answers to all of the questions you have about your stereo system. It's the most complete test record of its kind—contains the widest range of check-points ever included on one test disc! And you need no expensive test equipment. All checks can be made by ear!

*Note to professionals: The Model 211 can be used as a highly efficient design and measurement tool. Recorded levels, frequencies, etc. have been controlled to very close tolerances—affording accurate numerical evaluation when used with test instruments.*

### DON'T MISS OUT—ORDER NOW

The Model 211 Stereo Test Record is a disc that has set the new standard for stereo test recording. There is an overwhelming demand for this record and orders will be filled by ELECTRONICS WORLD promptly upon receipt. At the low price of \$4.98, this is a value you won't want to miss. Make sure you fill in and mail the coupon together with your check (\$4.98 per record) today.

### FILL IN AND MAIL TODAY!

Stereo Test Record  
P. O. Box 3110  
Church St. Station, New York, N.Y. 10008

Please send \_\_\_\_\_ test records at \$4.98 each, **postpaid**.  
My check (or money order) for \$\_\_\_\_\_ is enclosed.  
(Outside U.S.A. please send \$7.00 per record ordered.) N. Y. State residents please add local sales tax.

Name \_\_\_\_\_  
(PLEASE PRINT)

Address \_\_\_\_\_

City \_\_\_\_\_ EW-87

State \_\_\_\_\_ Zip Code \_\_\_\_\_

**PAYMENT MUST BE ENCLOSED WITH ORDER**



circuit may also perform *scaling* and *weighting* operations. For instance, a 30,000-ohm feedback resistor would produce an output equal to minus three times the sum of the inputs; a smaller feedback resistor would have the opposite effect. By changing only one input resistor without changing the other, one input may be weighted more heavily than the other. Thus, by a suitable choice of resistors, the basic summing circuit could perform such operations as  $E_{OUT} = -0.5(E_1 + 3E_2 + 0.6E_3)$ .

Subtraction is performed by inverting one input signal and then adding.

Two very important mathematical operations are *integration* and *differentiation*. Integration is simply finding the area under a curve, while differentiation involves finding the slope of a curve at a given point. The op-amp integration circuit is shown in Fig. 6B, while the differentiation circuit is shown in Fig. 6C. The integrator also serves as a low-pass filter, while the differentiator also serves as a high-pass filter, both with 6 dB/octave slopes.

The differentiator circuit's gain increases indefinitely with frequency, which obviously brings about high-frequency noise problems. The circuit cannot be used as shown. Fig. 6D shows a practical form of differentiator in which a gain-limiting resistor and some high-frequency compensation have been added to limit the high-frequency noise, yet still provide a good approximation to the derivative of the lower frequency inputs.

These two circuits are very important in solving advanced problems, particularly mathematics involving *differential equations*. Since most of the laws of physics, electronics, thermodynamics, aerodynamics, and chemical reactions can be expressed in differential-equation form, the use of operational amplifiers for equation solution can be a very valuable and powerful analysis tool.

### Active Network Synthesis

Perhaps the newest area in which operational amplifiers are beginning to find wide use is in active network synthesis. There is increasing pressure in industry to minimize the use of inductors. Inductors are big, heavy, expensive, and never obtained without some external field, significant resistance, and distributed capacitance. Worst of all, no one has yet found any practical way to stuff them into an integrated-circuit package. If we can find some circuit that obeys all the electrical laws of inductance without the necessity of a big coil of wire and a core, we have accomplished our purpose. Operational amplifiers are extensively used for this purpose.

One basic scheme is shown in Fig. 7A. If two networks are connected around an op amp as shown, the gain will equal the ratio of the transfer impedances of the two networks. Since we are using three-terminal networks, and since the op amp is capable of adding energy to the circuit, we can do many things with this circuit that are impossible with two-terminal passive resistors and capacitors.

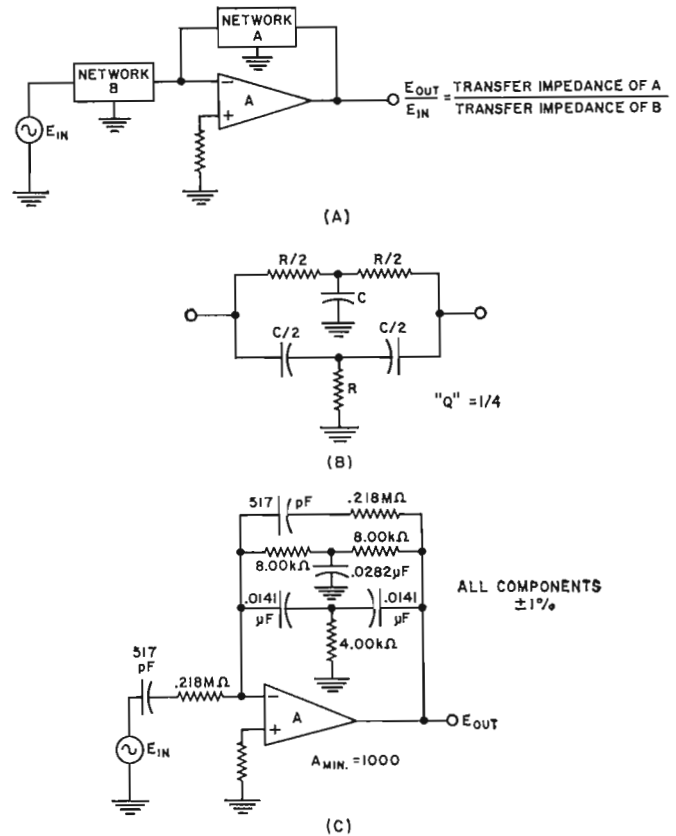

Fig. 7. Operational amplifiers in active network synthesis. (A) One form of active filter. (B) A twin-T network is identical to an LC parallel resonant circuit except for the "Q". (C) Circuit to realize "Q" of 14 without using an inductor.

Fig. 7B shows an interesting three-terminal network called a twin-T circuit. It exhibits resonance in the same manner as an ordinary LC circuit does. It has one limitation—its maximum "Q" is only 1/4. If we combine an op amp with a parallel twin-T network, we can *multiply* the "Q" electronically to any reasonable level. A gain of 40 would bring the "Q" up to 10. We then have a resonant "RLC" circuit of controllable center frequency and bandwidth with no large, bulky inductors required even for low-frequency operation.

One example is shown in Fig. 7C where an operational amplifier is used to realize a resonant effect and a "Q" of 14 at a frequency of 1400 Hz. As the desired "Q" increases, the tolerances on the components and the gain become more and more severe. From a practical standpoint, values of "Q" greater than 25 are very difficult to realize at the present time. Note that the entire circuit shown can be placed in a space much smaller than that occupied by the single inductor it replaces. ▲

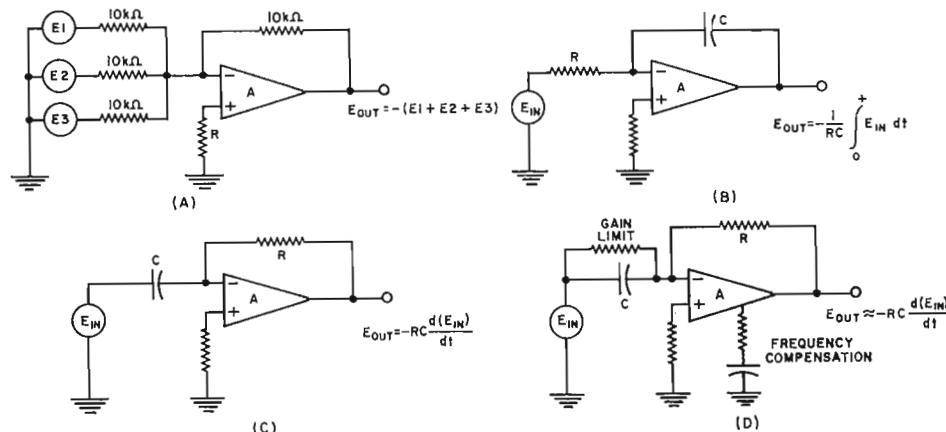

Fig. 6. Computer operational-amplifier circuits. (A) Addition. (B) Integration. (C) Differentiation. (D) Practical operational-amplifier differentiator.



**CATV: Past, Present & Future**  
(Continued from page 26)

Subscribers to CATV systems obviously like the service well enough to pay for it. Therefore, any curtailment of CATV services would certainly raise a storm of protest that Washington couldn't afford to ignore.

CATV not only provides greater program variety, it also improves picture quality. This is especially important for color, which is harder to receive than black-and-white. Thus, dealers in CATV cities invariably report a marked increase in color set sales once the system is turned on. In New York City, people subscribe to CATV strictly for picture improvement rather than to get distant channels.

Further, CATV has already proven its ability to provide needed local service. For example, more than 169 communities in the United States presently get educational TV programs via cable. Almost invariably this service is offered free to schools by CATV operators. At present, more than 156,000 students in 435 schools and colleges are served by CATV.

In addition to educational TV, some CATV systems presently provide one or more of the following types of services:

1. A local time-music-weather channel.

2. A local channel for the use of city officials, charitable institutions, and to cover local events.

3. A U.S. Weather Bureau "hot line". Some Florida CATV systems provide for the Weather Bureau to report emergency information at any time, with the "hot line" overriding the audio on all channels on the system. Thus subscribers get fast, accurate information when a storm is approaching.

4. Coverage of local sports events such as high-school basketball games.

Virtually all CATV program origination until now has been done on a non-profit basis, for its public-relations value. CATV operators have been careful not to rock the boat. They didn't want to change their image as an antenna-only service. Soon, however, operators may feel that they have nothing to lose from going aggressively into program origination for profit. It may be that CATV will provide much needed local channels in many areas of the country.

While the future of CATV is uncertain, it still appears bright. This is because the proponents claim that cable is the most economical way of providing maximum program variety and picture quality to the greatest number of people, and freeing the airwaves for use by mobile radio services and other such uses. ▲

*Why settle for less? Buy the Best!*

THE FABULOUS

**MARK TEN** CAPACITIVE DISCHARGE IGNITION SYSTEM



Available in easy-to-build kit form at only **\$29.95** ppd.!

Only **\$44.95** ppd.!

Dramatically improve the performance of your car—or any vehicle. Racers and Pacers from Sebring to Suburbia by the thousands attest to the peerless performance of the Mark Ten. Delta's remarkable electronic achievement, proven for four years, is often copied, never excelled.

**Ready for these?**

- ▲ Dramatic increase in acceleration
- ▲ Longer point and plug life
- ▲ Improved gasoline mileage
- ▲ Complete combustion
- ▲ Smoother performance

**Ready? Order today!**

**BE YOUR OWN MECHANIC**



Tune-up

**DWELL METER \$12.95** ppd.

A universal precision instrument for use in tuning all vehicles, regardless of the number of cylinders or battery polarity. Gives correct point dwell readings on vehicles equipped with capacitive discharge, transistor or conventional ignition. Precision accuracy at low cost.

- ▲ Portable, high-impact case for rugged work
- ▲ Large, easy-to-read 3½ inch precision jeweled meter
- ▲ Wide scale — reads dwell angles in degrees
- ▲ All solid state



Tune-up

**TACHOMETER \$14.95** ppd.

A universal precision instrument for making carburetor adjustments on all vehicles, regardless of the number of cylinders or battery polarity. Gives precise RPM readings on vehicles equipped with capacitive discharge, transistor or conventional ignition. Gives you better gas mileage, fuel savings and peak engine operation.

- ▲ Large, easy-to-read 3½ inch precision jeweled meter
- ▲ Portable, high-impact case for rugged work
- ▲ Range: 0 to 1200 RPM
- ▲ All solid state



**DELTA PRODUCTS, INC.**

P.O. BOX 1147 EW • GRAND JUNCTION, COLORADO 81501

Enclosed is \$\_\_\_\_\_ Ship prepaid.  Ship C.O.D.  
Please send:  Dwell Meters @ \$12.95  Mark Tens (Assembled) @ \$44.95  
 Tach Meters @ \$14.95  Mark Tens (Delta Kit) @ \$29.95

Specify —  Positive Ground  Negative Ground  6 or  12 volt  
(12 volt positive or negative ground only)

Car Year \_\_\_\_\_ Make \_\_\_\_\_

Name \_\_\_\_\_

Address \_\_\_\_\_

City/State \_\_\_\_\_ Zip \_\_\_\_\_

CIRCLE NO. 120 ON READER SERVICE CARD



# Versatile Transistor Tester

By M. J. MOSS

*This battery-powered transistor tester checks gain, leakage, and breakdown voltage of small-signal and power transistors.*

THE transistor checker described here represents a different approach to transistor testing because of its simplicity of operation and lack of critical adjustments. There is no "on-off" switch so that the battery-powered portable checker is ready for instant use. It is virtually impossible to damage either the meter or the transistor with any possible combination of the front-panel switches. This instrument will measure leakage, gain, and breakdown voltage for both *p-n-p* and *n-p-n* small-signal transistors as well as leakage and gain for *p-n-p* or *n-p-n* power transistors. An additional feature is a zener breakdown test. Determination of transistor *beta* ( $\beta$ ) is made by static-type measurement analogous to the emission tube tester which indicates a specified plate current for a given d.c. bias.

The gain of a transistor (*beta*) can be represented by the ratio of collector current to base current. Several methods are available which will measure this quantity. The first method is obviously to determine the collector current and base current with accurate meters and make the necessary calculations.

Another technique is to adjust a calibrated potentiometer supplying base current until a specified value of collector current is flowing. Gain measurement in this checker uses a fixed base current and indirect measurement of the collector current. If a load resistor is placed in series with the collector, the voltage drop across this resistor will be directly proportional to the collector current flowing through it. By proper calibration, a meter could be made to read directly from a linear scale.

## Small-Signal Transistors

The basic circuit used in measuring small-signal current gain is shown in Fig. 1A for a *p-n-p* transistor. The base current is essentially fixed at  $20 \mu\text{A}$  as shown by  $(6.75 - V_{BE}) / 300\text{k}\Omega \approx 20 \mu\text{A}$ , where at room temperature  $V_{BE}$  equals .3 volt for germanium and .7 volt for silicon.

Most transistors used today have values of  $\beta$  in the 20 to 200 range. A large proportion of these devices are in the 50 to 100 range. Thus, for a *beta* of 50, the collector current is  $50 \times 20 \mu\text{A}$  or 1 mA; for a *beta* of 100, the collector

current is 2 mA; and so on for various  $I_c$ , *beta* ratios.

The main supply voltage is a 6.75-volt battery (B1), so the load resistor is equal to the main supply divided by the maximum collector current at a  $\beta$  of 200. This value (R8) is 1600 ohms. Meter M1 is used as a voltmeter to measure the voltage drop across R8. For a full-scale meter deflection with 6.75 volts, a series resistance of 130,000 ohms is required (meter resistance is considered).

Damage to either the transistor or the meter is virtually impossible because of current limiting by the resistors in the meter circuit.

## Power Transistors

Fig. 1B shows the basic test circuit for measuring *beta* of power transistors.

The value of collector current for checking a power transistor should be higher than that for a small-signal transistor because the higher leakage currents tend to mask a true measurement of  $\beta$ . Since the capacity of the 6.75-volt battery is quite limited when large currents are drawn from it, the value of collector current was set at 50 mA to correspond to a  $\beta$  of 100. This fixes collector load R9 at a value of 68 ohms. For a collector current of 50 mA and a  $\beta$  of 100, the base current must be  $500 \mu\text{A}$ . This determines the value of R7 at 12,000 ohms.

A built-in safety feature of the checker is that if a small-signal transistor is plugged into the socket and the switch is moved to the power position, the transistor is removed electrically from the circuit so that no excessive value of collector current can flow through it.

## Leakage

The usual test for leakage in transistors is the reverse-biased collector-to-base current known as  $I_{CBO}$ . The test, whose circuit is shown in Fig. 1C, is performed by placing meter M1 in series with a current-limiting resistor (R4) and the 6.75-volt battery. Series resistor R4 limits the current through the meter to  $100 \mu\text{A}$  if a shorted transistor is placed in the checker. The values of  $I_{CBO}$  are obtained with 6.75 volts since this figure is below the zener or avalanche break-

Fig. 1. The basic test circuits used in the versatile transistor/diode tester. There are no critical adjustments to be made

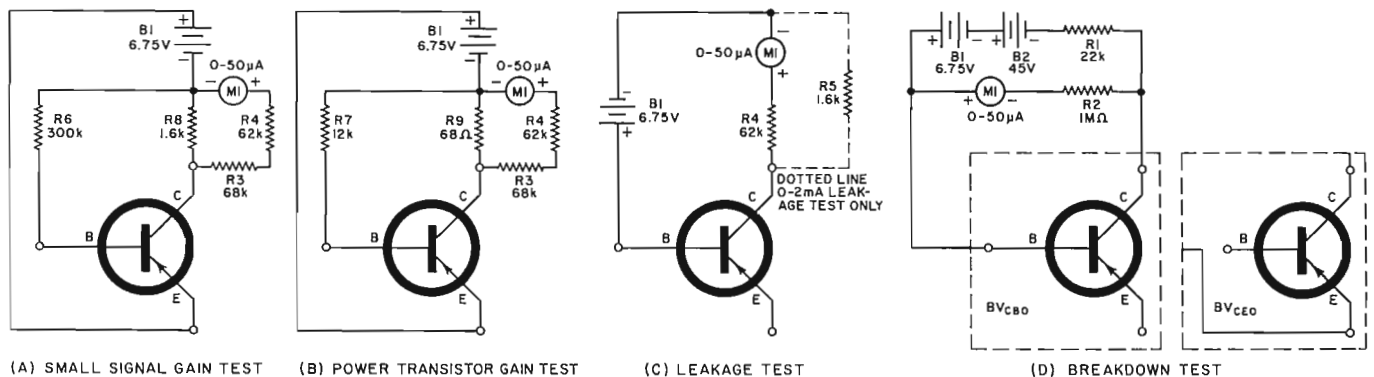



down voltage in most transistors. It is possible to measure the collector-to-emitter leakage current ( $I_{CEO}$ ) by simply interchanging the base and emitter leads during the leakage test. This value is usually  $\beta$  times  $I_{CBO}$ .

If a leakage current greater than 50  $\mu$ A exists, as may be the case with power transistors, a 0- to 2-mA scale is provided by switching in resistor  $R5$  to change the full-scale reading of the meter.

If a different full-scale reading is desired for the high-leakage position, the value of  $R5$  can be changed. For example, full scale of 1 mA would require a 3300-ohm resistor, whereas for 4 mA full scale, an 820-ohm resistor would be used. Again, a shorted transistor will cause a maximum of 100  $\mu$ A to flow through the meter, protecting it even in the worst case.

### Collector Breakdown

A test which can provide very useful information is the collector breakdown test. Both  $BV_{CEO}$  (breakdown voltage from collector to emitter with the base open) and  $BV_{CBO}$  (breakdown voltage from collector to base with the emitter open) are provided with up to 50 volts breakdown readable.

The question of whether or not breakdown will permanently damage a transistor invariably arises. The answer is that it depends upon the power dissipated by the collector when actual breakdown occurs. Most modern transistors will dissipate 50 mW quite easily and a large number of devices are actually rated higher. The maximum power dissipated during the breakdown test is limited to 20 mW. This occurs only at a breakdown voltage of 25 volts, and dissipated power falls off rapidly as the breakdown voltage drops below or rises above the 25-volt point.

This test provides the data necessary to decide whether or not a transistor should be used in a high-voltage circuit, such as 22.5 or even 45 volts. When the checker is switched to the breakdown mode, a 45-volt battery ( $B2$ ) is inserted in series with the main 6.75-volt battery ( $B1$ ) as shown in Fig. 1D. A series-limiting resistor ( $R1$ ) is provided to limit maximum power dissipation. The meter is connected as a 0 to 50 voltmeter across the collector to emitter, or collector to base, and reads the voltage at which breakdown occurs.

### Zener Breakdown

Another test which can be easily performed by this checker is the determination of the breakdown voltage of a zener diode. To test a zener diode, it should be connected across the collector-to-emitter terminals of either the socket or the binding posts. With the checker in the breakdown mode and  $BV_{CBO}$  switched in, the breakdown voltage of the zener can be read directly on the 0- to 50-volt scale. If the reading is less than one volt, it is a single-anode zener diode and the  $p-n-p-n-p-n$  switch should be reversed to the opposite position. The voltage can now be read. If the breakdown voltage is the same in both  $p-n-p$  and  $n-p-n$  positions, then the diode is a double-anode zener.

There are two simple ways of determining whether a particular transistor is germanium or silicon. The usual value of leakage current for a germanium transistor is from 1 to 4  $\mu$ A. The leakage current for a silicon transistor is generally not measurable on a 0- to 50- $\mu$ A scale as it is usually much less than 1  $\mu$ A. Another method is to measure the forward voltage drop of the collector-to-base junction,

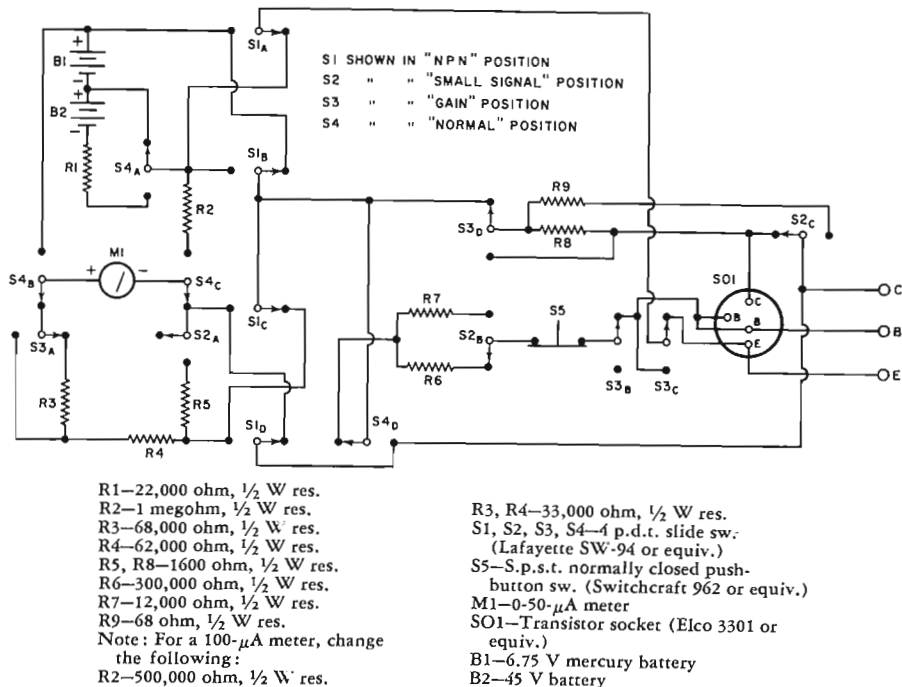

Fig. 2. Schematic and parts list for the versatile transistor/diode tester.

which is about 0.7 volt for silicon and 0.3 volt for germanium. This can be read on the meter by switching to the breakdown mode and  $BV_{CBO}$  switch positions and then reversing the polarity of the  $n-p-n-p-n-p$  switch to obtain the lowest meter reading. The lowest reading is the voltage drop across the forward-biased collector-to-base junction in the transistor.

The final circuit for the tester is shown in Fig. 2. Although a 0- to 50- $\mu$ A meter is specified, a 0- to 100- $\mu$ A meter may be more readily available. If so, then the only changes necessary are to make  $R3$  and  $R4$  both 33,000 ohms and  $R2$  500,000 ohms. The ranges will be: leakage, 0 to 100  $\mu$ A or 0 to 2 mA;  $\beta$ , 0 to 200; and breakdown voltage, 0 to 50 volts.

The meter can be physically eliminated from the circuit by placing two phone-tip jacks on the chassis and wiring the tip jacks in place of the meter. In this case, the external meter can be the 0- to 50- $\mu$ A current range available on most 20,000-ohms-per-volt, volt-ohm-milliamper

Table 1. Summary of tests performed by instrument.

S1	S2	S3	S4	
as needed	S. Sig.	Beta	Normal	Small-signal gain of "p-n-p" or "n-p-n" transistor
as needed	Power	Beta	Normal	Power transistor gain. Range of beta is 0 to 200
as needed	0-50 $\mu$ A	$I_{CBO}$	Normal	Leakage between collector and base. Range is 0 to 50 $\mu$ A
as needed	0-2 mA	$I_{CBO}$	Normal	Leakage between collector and base. Range is 0 to 2 mA
as needed	S. Sig.	$BV_{CBO}$	Breakdown	Breakdown voltage between collector and base with emitter open. Range is 0 to 50 volts
as needed	S. Sig.	$BV_{CEO}$	Breakdown	Breakdown voltage between collector and emitter with base open. Range is 0 to 50 volts
as needed	Power	$BV_{CBO}$	Breakdown	Breakdown voltage between collector and base with emitter open. Range is 0 to 50 volts
as needed	Power	$BV_{CEO}$	Breakdown	Results of this test not valid for power transistors
as needed	S. Sig.	$BV_{CBO}$	Breakdown	Zener diode test. Range is 0 to 50 volts



# Earn Extra Income in MOBILE-RADIO MAINTENANCE!



CITIZENS BAND  
AIRCRAFT . . . MARINE  
. . . PUBLIC SAFETY . . .  
BUSINESS AND INDUSTRIAL  
RADIO

961,000 new transmitters added  
last year, with the curve still  
going upward!

## MEASURE FREQUENCY with the LAMPKIN 105-B

- Just this ONE instrument . . . with no extra crystals or factory adjustments . . . will measure ALL channels from 100 KC to 175 MC. Only \$295.00.
- Ample accuracy for all mobile transmitters except for split-channels above 50 MC—for these use inexpensive accessory PPM Meter.
- Pin-point signal generator for receiver final alignment.
- Internal quartz crystal standard . . . correctable to WWV.

## MEASURE FM DEVIATION with the LAMPKIN 205-A

- Just this ONE meter measures all mobile channels, 25 MC to 500 MC.
- Reads instantaneous true peak swing due to FM modulation.
- Set selective-calling tone signals using 0-1.25 KC or 0-2.5 KC ranges of 205-A Quad Scale, \$340.00. Dual Scale model, 12.5 KC and 25 KC ranges, only \$290.00.
- Oscilloscope jack for true wave form.
- 3-inch meter indicates directly in peak KC.



105-B 205-A

### FREE BOOKLET!

Send for "HOW TO MAKE  
MONEY IN MOBILE-RADIO  
MAINTENANCE".

MAIL COUPON TODAY!

At no obligation to me, please send free booklet and information on Lampkin meters.

Name \_\_\_\_\_

Address \_\_\_\_\_

City \_\_\_\_\_ State \_\_\_\_\_ Zip \_\_\_\_\_

**LAMPKIN LABORATORIES, INC.**  
MFM Div., Bradenton, Fla. 33505

CIRCLE NO. 109 ON READER SERVICE CARD

## GET INTO ELECTRONICS



V.T.I. training leads to success as technicians, field engineers, specialists in communications, guided missiles, computers, radar and automation. Basic & advanced courses in theory & laboratory. Electronic Engineering Technology and Electronic Technology curricula both available. Assoc. degree in 29 mos. B. S. also obtainable. G.I. approved. Graduates in all branches of electronics with major companies. Start September, February. Dorms, campus. High school graduate or equivalent. Write for catalog.

**VALPARAISO TECHNICAL INSTITUTE**  
Dept. RD, Valparaiso, Indiana

meters such as the Simpson 260 or the Triplett 310.

No special wiring precautions are necessary as all measurements are made in d.c. In the front-panel view shown in Fig. 3, the switches are labeled (S1) "PNP-NPN"; (S2) "0-50  $\mu$ A, S.Sig. — Power/0-2mA"; (S3) " $BV_{CEO}$ , Beta- $I_{CEO}$ ,  $BV_{CEO}$ "; and (S4) "Normal-Breakdown, 0-50 V." Great care should be exercised in wiring the switches as a mistake could mean a costly burnout of a meter or transistor.

### Operation

Assume that an unknown type of transistor is to be tested on the checker. Set up the switches at "PNP", "S. Sig." (small signal), " $I_{CEO}$ ", and "Normal" positions and place the transistor in the socket or attach the leads to the appropriate binding posts. If the meter pointer swings to full scale, switch S1 to "NPN". If the meter stays off scale for both "NPN" and "PNP" positions, try the "Power" position before deciding if the transistor is bad. A shorted transistor will usually cause the meter to remain full scale for "NPN" or "PNP" in either S2 position.

Next, switch S3 to the "Beta" posi-

Fig. 3. (Top) The front panel of the tester. (Below) Meter scale modifications for tests.

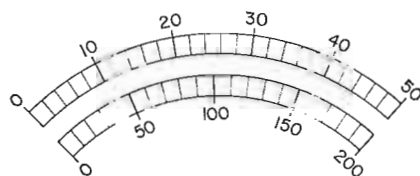
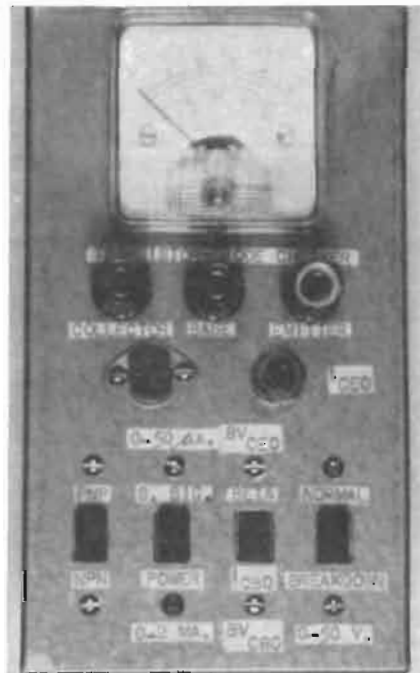

tion and read the value of  $\beta$  directly on the 0 to 200 scale. A transistor with a  $\beta$  of 30 up to 150 is acceptable for most well-biased circuits. However, it is not possible to say that a transistor with a  $\beta$  of 20 or 200 is necessarily bad. It depends upon the exact application and circuit where the particular transistor is used. The collector-to-emitter breakdown voltage can be measured by switching S4 to the "Breakdown" mode.

Voltage readings on the meter will be calibrated in the range of 0 to 50 volts and may be read directly. This measurement is relative and no simple rule exists for determining whether or not a transistor is good. In general, the higher the  $\beta$  and leakage of a transistor, the lower  $BV_{CEO}$  will be. If the meter reads full scale, the breakdown voltage is in excess of 50 volts and cannot be measured with this checker. A more significant measurement of breakdown voltage is the collector-to-base breakdown,  $BV_{CBO}$ , which can be measured by placing S3 in the " $BV_{CBO}$ " position. This reading is higher than the  $BV_{CEO}$  voltage and is a good indicator of the maximum voltage which should be allowed across the collector-to-base junction of the transistor. The above tests can also be performed on a power transistor.

If the leakage current is less than 50  $\mu$ A as read on the "0-2 mA" scale, it is possible to drop down to the more sensitive leakage scale by placing S2 in the "0-50  $\mu$ A" position. However, for the measurement of  $\beta$ , S2 should be switched back to the "Power" position. The reading of  $BV_{CEO}$  is not valid for a power transistor because of the high value of collector-to-emitter leakage current. The value of  $BV_{CBO}$  is usable, although it is not quite as reliable as it is for the small-signal transistor.

A summary of the tests which can be performed is given in Table 1.

Push-button switch S5 (" $I_{CEO}$ ") shown in Fig. 2 allows base current to be removed while the transistor is in the common-emitter connection. When the button is depressed, collector-to-emitter leakage current ( $I_{CEO}$ ) can be read directly on the meter. When measuring small-signal transistors, the full-scale reading will be 4 mA, whereas for power transistors the full-scale reading is 100 mA. In general, the  $I_{CEO}$  for small-signal transistors is quite small, being much less than 500  $\mu$ A. The  $I_{CEO}$  for a power transistor, however, can be as high as 50 mA. Because of this high  $I_{CEO}$  in power transistors, it might be desirable to obtain a more accurate reading of the value of  $\beta$ . This can be accomplished by simply subtracting the  $\beta$  reading when the button is depressed from the  $\beta$  reading obtained when S3 is in the "Beta" switch position. ▲



# Calculation of Potentiometer Linearity and Power Dissipation

By DAVID L. HEISERMAN

*The linearity of a potentiometer can be completely changed by the position of the wiper arm and the resistance of the load.*

**M**OST potentiometers used in communications and industrial electronic equipment are specified according to three characteristics: total resistance of the resistive material, maximum power dissipation, and the linearity of resistance as a function of shaft position. Both engineering technicians who must modify existing circuits and experimenters who are designing their own circuits face the problem of choosing the right potentiometer for the job at hand. As will be shown, this choice is not as simple as just selecting a likely looking pot from a catalogue.

Selecting the appropriate pot is somewhat more complex than many people might be led to believe. The discussion that follows points out the problems involved in selecting potentiometers for loaded voltage-divider circuits and describes how to solve the problems using a few equations and the manufacturer's specifications.

The circuit in Fig. 1 shows the conventional method of controlling the voltage across a load impedance  $R_L$ . With this particular voltage-divider arrangement, a clockwise rotation of the shaft decreases the voltage applied to the load. If a linear voltage response is desired, the natural tendency is to choose a pot that has a resistive element specified as linear. The fact that the winding is linear, however, is no guarantee that it will produce a linear response under load. The curves in Fig. 1 show how the linearity of the output voltage changes with the ratio of load impedance to specified potentiometer resistance.

When the load resistance is infinite (no load), the response of a linear pot is truly linear. As the load impedance decreases, however, the response becomes more non-linear.

Fig. 1. These curves show how the pot linearity varies with the load.

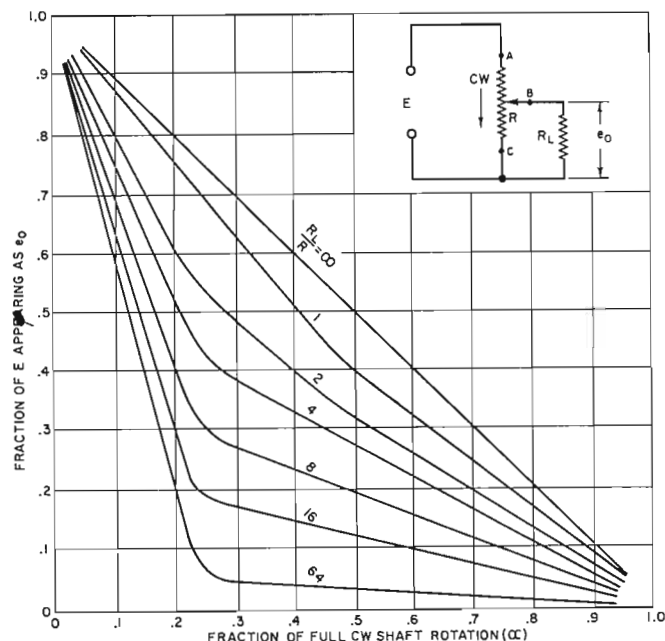

In theory, it is impossible to obtain a linear response from a linear taper pot that is loaded with any impedance. In practice, though, an  $R_L/R$  ratio of 10 or more gives a response that is fairly linear.

Likewise, a log taper pot will produce a truly log response only if the load impedance is infinite. As the  $R_L/R$  ratio becomes smaller, the deviation from the specified log response becomes greater. When loaded, "voltage-divider" pots with certain non-linear characteristics will compensate for this undesirable loading effect and produce a nearly linear output. A discussion of non-linear pots, however, is beyond the scope of this article.

Because of the unwanted effects of pot loading, the potentiometer resistance should be kept as low as possible with respect to the load impedance.

However, a good linear response is bought at a high price—the smaller the specified pot resistance, the greater the current through its contacts and resistive elements.

## Power Dissipation

The potentiometer power dissipation specified by the manufacturer is actually a reflection of the maximum current that can pass safely through any of the pot's three connectors or any portion of its resistive element. The following equation enables the user to calculate this maximum current rating:  $I_{max} = \sqrt{P/R}$  where  $I_{max}$  is the maximum amount of current that can pass safely through any part of the pot,  $P$  is the specified power rating of the pot, and  $R$  is the specified resistance of the pot.

For example, a 10,000-ohm, 1-watt potentiometer can safely pass  $\sqrt{1/10^4}$  amperes, or 10 milliamperes.

The current through a voltage-divider circuit such as the one in Fig. 1 is at a maximum when the wiper arm is in the position that makes the circuit strictly parallel ( $\alpha = 0$ ).

The maximum current through any part of a loaded pot may then be determined by using the equation  $I_{max} = E [(R + R_L)/RR_L]$  where  $I_{max}$  is the maximum current through any part of the pot (at  $\alpha = 0$ ),  $E$  is the d.c. or r.m.s. value of applied voltage, and  $R_L$  is the load impedance. Substituting  $I_{max}$  from this latter equation for  $I$  in the first equation, we find the relationship  $P_{req} = E^2 [(R + R_L)/RR_L]$  where  $P_{req}$  is the maximum power dissipation of the pot.

## Example

Suppose the d.c. or r.m.s. value of applied voltage ( $E$ ) is 10 volts and the load impedance ( $R_L$ ) is 10,000 ohms. If a good linear response is desired, what are the necessary potentiometer specifications?

Consider the linearity problem. The resistance of the pot should be no greater than 0.1 times  $R_L$ , so we can select a 1000-ohm potentiometer. The maximum power dissipation of this pot in this circuit can be found by applying the second equation. In this case,  $P_{req} = 10^2 [(10 \times 10^3 + 1 \times 10^4)/(10 \times 10^3) (1 \times 10^3)]$  or 0.1 watt.

The specifications for this particular pot should be 1000 ohms, 1 watt, and a linear taper. ▲



**“He’s a good worker.  
I’d promote him  
right now if he had  
more education  
in electronics.”**



## **Could they be talking about you?**

You'll miss a lot of opportunities if you try to get along in the electronics industry without an advanced education. Many doors will be closed to you, and no amount of hard work will open them.

You can build a rewarding career if you supplement your experience with specialized knowledge of one of the key areas of electronics. As a specialist, you will enjoy security, excellent pay, and the kind of future you want for yourself and your family.

Going back to school isn't easy for a man with

a full-time job and family obligations. But CREI Home Study Programs make it possible for you to get the additional education you need without attending classes. You study at home, at your own pace, on your own schedule. You study with the assurance that what you learn can be applied to the job immediately.

CREI Programs cover all important areas of electronics including communications, radar and sonar, even missile and spacecraft guidance. You're sure to find a program that fits





your career objectives. You're eligible for a CREI Program if you work in electronics and have a high school education. Our FREE book gives complete information. Air-mail postpaid card for your copy. If card is detached, use coupon at right or write: CREI, Dept. 1108E, 3224 Sixteenth Street, N.W., Washington, D.C. 20010.



**The Capitol Radio Engineering Institute**  
*A Division of McGraw-Hill, Inc.*  
**Dept. 1108E, 3224 Sixteenth Street, N.W.**  
**Washington, D.C. 20010**

Please send me FREE book describing CREI Programs. I am employed in electronics and have a high school education.

NAME \_\_\_\_\_ AGE \_\_\_\_\_

ADDRESS \_\_\_\_\_

CITY \_\_\_\_\_ STATE \_\_\_\_\_ ZIP CODE \_\_\_\_\_

EMPLOYED BY \_\_\_\_\_

TYPE OF PRESENT WORK \_\_\_\_\_  G.I. BILL

I am interested in  Electronic Engineering Technology  
 Space Electronics  Nuclear Engineering Technology  
 Industrial Electronics for Automation  
 Computer Systems Technology

**APPROVED FOR TRAINING UNDER NEW G.I. BILL**





# J OHN FRYE

*A discussion on two small dictating/transcribing devices that differ widely in design, sophistication, and price.*

## MINIATURE DICTATION RECORDERS

WHEN Barney entered the air-conditioned coolness of the front office of Mac's Service Shop, he was sure he heard the boss talking to someone back in the service department; but when the youth walked through the door, Mac was alone, hunched over a technical magazine spread out on the service bench in front of him and reading aloud into a small beige-colored object held in his right hand. Sensing Barney's presence, he stopped talking and turned around with a self-conscious expression.

"Been out in that sizzling August sun too long, huh?" Barney accused.

"No, I'm not sun-struck, and I wasn't talking to myself. Listen." He made a couple of quick adjustments on the front of the beige object, and his voice, with excellent quality, came from it reciting the paragraph from *ELECTRONICS WORLD* he had just been reading.

"Man, they're making tape recorders smaller all the time!" Barney marveled. "What kind is that?"

"Calling this a tape recorder is like calling a diamond a chunk of carbon," Mac reproved him. "This is a highly portable, very specialized recorder intended to take and play back dictation. Actually, it's an *IBM Executary*® Model 224. I asked for a demonstration, and the salesman left it with me to examine while he makes a couple of other calls here in town."

"You thinking of buying it?"

"I plan to buy some sort of hand-held dictation device."

"What for?"

"I've lots of uses for one. It would be wonderful for nailing down those ideas that flit through my mind while I'm lying in bed, driving the car, or working on a customer's set and which escape because I can't—or at least don't—jot them down. With something like this, I'll simply pick it up and talk my idea into it. And it will be dandy to use when I'm skimming through the many magazines we take and come across an idea or service hint I want to remember. I'll read these items aloud and go on with my reading. Matilda can transcribe and file them later."

"Yeah!" Barney said, beginning to wax enthusiastic. "And we can use it to record service lectures, to take inventory, and to record customers' complaints when they bring in their sets for service. I see by this instruction manual there is a telephone pickup accessory. Matilda can use that to record service calls that come in by telephone. This will speed things up and keep the telephone free for more calls. But clue me in on what makes this so different from the ordinary portable tape recorder."

Before answering, Mac released a catch and slid the recorder mechanism halfway out of the bottom of the case, where it locked into position. "See this short, wide belt of magnetic tape?" he asked. "It takes the recording. I estimate it to be about 3" wide and about 12" long if cut and spread out. During recording, the belt is rotated by the motor, and at the same time a feed screw moves the recording and playback heads across the width of the moving belt, always from left to right. This produces a closely spaced spiral recording path on the outside of the belt."

"Just how long a recording can you make on a belt?"

"Up to ten minutes. The belt makes a revolution every six seconds, which means it passes the heads at about 2 ips—plenty fast enough for excellent voice quality. It also means there are 100 recorded lines on a fully recorded belt. Notice this little white paper index slip with a mark for every ten lines up to 100. A new one is used with each unrecorded belt. A pointer attached to the moving tape heads moves across the index slip and provides a means of indexing the beginning and end of each recording. Furthermore, on the front of the instrument is a two-position instruction control knob. When it is moved to the "Letter" position, it puts a visible mark on the upper half of the index slip at the spot where the pointer is at that moment. A secretary transcribing the dictation can observe the distance between two such marks and determine the number of lines required by that dictated letter. When the knob is moved to the "Secretarial" position, it similarly marks the bottom half of the slip to show the secretary you have dictated some special instructions at that point that should be reviewed before starting the letter."

"Does she have to listen to the whole belt from the beginning to reach that point?"

"Not at all! That's an advantage of this arrangement. She simply pushes up on this little button beneath the recording-head pointer that lifts the pawl out of the feed screw, slides the pointer to where she wants to listen, and releases the button. The pawl drops into the screw and the head starts moving. She has the same ease of selection and review that a disc jockey has with the tonearm of his transcription turntable."

"Before sliding the mechanism back in the case, I want to show you two other features. Naturally, the recorder erases old material as new material is taped over it; but if you want to erase the entire belt in a hurry, you do it so—" Saying this, Mac picked up a little flat white magnet whose length exceeded the width of the moving belt against which he held it for six seconds, or one complete revolution. "That's all there is to it," he explained; "and this little knob next to the rear of the speaker is a record volume control. You can turn it up to record weak or distant sounds or back it off for close-talking in a noisy location."

"What's that knob do, the one with the tuning fork emblem beside it?"

"That's the tuning control. It's not a motor-speed control, as I first thought. It permits the moving playback head to be shifted slightly ahead or back so that it is exactly centered over the recorded track on the belt moving beneath it. Thinking about it, you can see that if the belt were removed and replaced the playback head might be riding between two of those spiral turns. The tuning control takes care of this. You simply adjust it for clearest sound."

"While we're at it, let's discuss the other controls. This knob is the combined on-off switch and playback volume control. To the left of it is the battery condition indicator. When the pointer doesn't move up into the white area during record or playback, you replace the special 10.7-volt



mercury alkaline battery which provides about sixteen hours of use and costs \$3.50.

"The flat dictate bar is operated with the thumb. Below it is a three-position record, listen, and back-space operating key. With this in the 'Record' position, no current is drawn until you depress the dictate bar; then the belt moves and any sound entering the mike is recorded. With the key in the 'Listen' position, the belt moves as long as the switch is on, and you hear any recorded material passing beneath the head. To stop the playback, you move the key to 'Record.' Finally, if the key is moved to the extreme right and released so that it comes back to 'Listen,' the head mechanism is shifted back one thread of the feed screw so that you hear repeated the last six seconds—or about ten words—of what you were saying or what was being played back. Each time you move the key to the right and release it, you back-space another six seconds.

"In addition to the telephone pickup you already noticed, various other accessories can be plugged into these receptacles on the top of the instrument. They include an earphone and a foot control for use by a secretary in transcribing. She can start and stop the playback without lifting her hands from the typewriter keyboard, and of course she can use the back-space feature.

"The Executary 224 measures 6 $\frac{1}{8}$ " long, 4 $\frac{3}{4}$ " wide, and 1 $\frac{3}{4}$ " deep. It weighs 28 ounces and fits the hand very comfortably."

As Mac finished speaking, he reached in his shirt pocket and pulled out another instrument only slightly larger than a pack of playing cards.

"This," he said, speaking into the little object almost concealed in his big hand, "is a still smaller dictation-type recorder, measuring only 4 $\frac{1}{2}$ " x 3" x 1 $\frac{1}{2}$ " and weighing less than twelve ounces. It's a Memocord® XJE IV, manufactured by the Stuzzi Works in Vienna, Austria and distributed and serviced in this country by Norfolk-Hill, Ltd., 35 Ninth Ave., New York City."

A few seconds before he finished speaking, he had released the red button on the left side of the recorder that he had been holding down, had moved up a lever on the right side, and had depressed a white button just above the red button. Now he moved the lever back down, and his voice, sounding somewhat tinny but quite understandable and recognizable, came from an opening no larger than a dime in the front of the recorder.

"This one records on a special quarter-inch-wide tape wound on reels only 1 $\frac{1}{8}$ " in diameter and having  $\frac{1}{16}$ " hubs. A reel holds a little less than 100 feet of this tape, and consecutive numbers from 000 to 500 are printed about every

## Low-drain Solid-state tone signal needs no amplifier

The Sonalert® Signal makes it a cinch to rig all sorts of alarm circuits for the home, shop, auto or boat. Works with just about any triggering device, operates on 6-28 VDC, draws only 3-14 ma. 110-volt AC model draws only as much current as a neon pilot lamp.

It's completely solid-state. No arcing contacts, no RF noise. Highest reliability. Tone output is either 2800 or 4500 Hz, at 68 to 80 db.

Ask your Mallory Distributor for booklet of ideas, circuits, projects. Mallory Distributor Products Company, a division of P. R. Mallory & Co. Inc., Indianapolis, Ind. 46206.

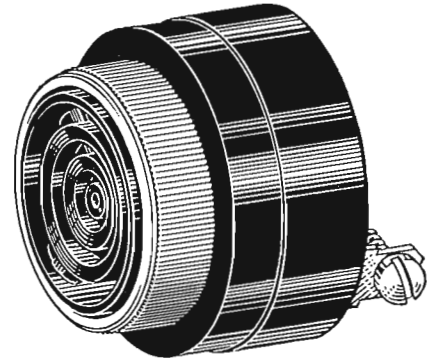

# MALLORY

CIRCLE NO. 108 ON READER SERVICE CARD

### PHOTOGRAPHY ANNUAL

A selection of the World's finest photographs compiled by the editors of Popular Photography. All editions \$1.25 each:

1966 — \$1.25.....#1	Order by number from
1967 — \$1.50.....#38	Ziff-Davis Service Div., 595 Broadway • New York,
	N. Y. 10012. Enclose add'l 15¢ per copy for shipping and handling (50¢ for orders outside U.S.A.)

### LEARN Electronics Engineering AT HOME

Fix TV, design automation systems, learn transistors, complete electronics. College level Home Study courses taught so you can understand them. Earn more in the highly paid electronics industry. Computers, Missiles, theory and practical. Kits furnished. Over 30,000 graduates now employed. Resident classes at our Chicago campus if desired. Founded 1934. Catalog, "Veta"—write for information about G I Bill Training.  
American Institute of Engineering & Technology  
1141 West Fullerton Parkway Chicago, Ill. 60614

Enjoy the "music-only" programs now available on the FM broadcast band from coast to coast.

- NO COMMERCIALS •
- NO INTERRUPTIONS •



It's easy! Just plug Music Associated's Sub Carrier Detector into multiplex jack of your FM tuner or easily wire into discriminator. Tune through your FM dial and hear programs of continuous, commercial-free music you are now missing. The Detector, self-powered and with electronic mute for quieting between selections, permits reception of popular background music programs no longer sent by wire but transmitted as hidden programs on the FM broadcast band from coast to coast. Use with any FM tuner. Size 5 $\frac{1}{2}$ " x 9". Shipping weight approx. 7 lbs.

**KIT \$49.50**  
(with pre-tuned coils, no alignment necessary)

**WIRED \$75.00**

**COVER \$4.95 EXTRA**  
Current List of FM Broadcast Stations with SCA authorization .....\$1.00

### MUSIC ASSOCIATED

65 Glenwood Road, Upper Montclair, New Jersey  
Phone: (201) 744-3387

CIRCLE NO. 104 ON READER SERVICE CARD

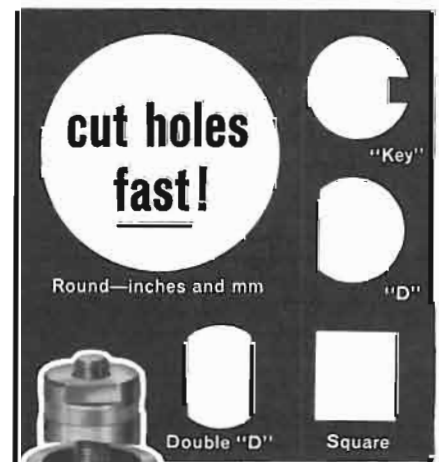

## with Greenlee punches

Here's the simple speedy way to cut smooth, accurate holes in metal, hard rubber, plastics, epoxy, etc.

Save hours of hard work... punch clean, true holes in seconds for sockets, controls, meters, and other components. Easy to operate. Simply insert punch in a small drilled hole and turn with a wrench. For use in up to 16-gauge metal. Available at leading radio and electronic parts dealers.



### GREENLEE TOOL CO

DIVISION OF GREENLEE BROS. & CO.

1866 Columbia Avenue, Rockford, Ill. 61101

CIRCLE NO. 113 ON READER SERVICE CARD



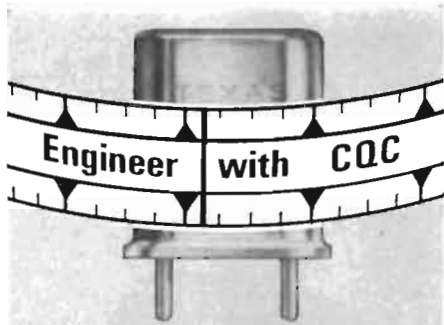

### MORE CONTROL

Control of quality throughout precision manufacturing gives you crystals that assure exact frequency control.

### MORE RELIABILITY

You'll stay on frequency better with CQC. And, you can rely on your CQC dealer to fill your needs promptly.

See your dealer for prices and data on CQC



## TEXAS CRYSTALS

Div. of Whitehall Electronics  
1000 Crystal Drive  
Fort Myers, Fla. 33901

Plants in Fort Myers and Los Angeles

CIRCLE NO. 198 ON READER SERVICE CARD

### VALUABLE books from E. & E.

#### NEW SINGLE SIDEBAND: THEORY AND PRACTICE

by Harry D. Hooten, W6TYH. The one-source reference guide to ssb. Covers the origin and principles of ssb, derivation of ssb signals, carrier suppression techniques, sideband selection, carrier generators, speech amplifiers and filters, ssb generators, balanced mixers and converters, low-power ssb transmitters, linear r-f amplifiers, ssb communications receivers, transceivers, tests and measurements. Includes chapters on how to build air-tested linear amplifiers. 352 pages. Hardbound.



Order No. EE-350, only..... \$6.95

#### NEW! 17th EDITION OF THE FAMOUS RADIO HANDBOOK

Tells how to design, build, and operate the latest types of amateur transmitters, receivers, transceivers, and amplifiers. Provides extensive, simplified theory on practically every phase of radio. Broadest coverage; all original data, up-to-date, complete. 832 pages. Order No. EE-167, only..... \$12.95



Order from your electronic parts distributor or send coupon below.

EDITORS and ENGINEERS, Ltd.

P.O. Box 68003, New Augusta, Indiana, Dept. EWE-8  
Ship me the following books:  
 No. EE-350  No. EE-167 \$\_\_\_\_\_encl.

Name \_\_\_\_\_  
Address \_\_\_\_\_  
City \_\_\_\_\_ State \_\_\_\_\_ Zip \_\_\_\_\_

CIRCLE NO. 94 ON READER SERVICE CARD

2 1/8" on the back of it. These numbers, visible through a little window in the side of the recorder, provide an index of the position of recordings.

"This control lever on the side is actually a combination clutch, tape-direction control, and channel selector. As you can see, in addition to the neutral center position, it has four possible positions. The tape doesn't move in the center position. In the #1 and #3 positions, it moves so that the numbers increase. In the #2 and #4 positions, the tape moves so that the numbers decrease. And each of the four positions places the head on a different tape track. Since the tape moves past the head at about one inch per second, each track provides about 15 minutes of recording time for a total of one hour for all four tracks."

"How about rewinding?"

"There's no fast rewind provision. You can shift the control lever to a position moving the tape in the opposite direction from that in which it was recorded and rewind it slowly that way. I prefer to use the manual rewind method provided. Both tape hubs project through openings in the back of the case, and each has a depression on the perimeter into which a pencil point can be inserted and used to rotate the reel. I can rewind an entire tape from end to end in less than a minute."

"How does the clutch work?"

"The motor-driven flywheel has a small rubber drive wheel on its shaft. The action of the control lever presses this drive against the rim of one reel or the other, and the reel rotation pulls the tape past the head. This method of drive results in some slight difference in tape speed from the beginning to the end of a tape, but since the tape is always moving at the recorded speed when being played back, this seems to have no effect. A motor-speed control lever on the bottom compensates for lowering battery voltage.

"Speaking of batteries, the Memocord uses two: a type AA penlight cell for the motor and a standard 9-volt radio battery, NEDA Type 1604, for the transistorized amplifier. The batteries are said to be good for 15 hours of use. Both recorders employ d.c. erase so as not to emit a signal from an erase oscillator, and both are licensed for use on commercial airplanes—an important consideration for the business man."

"This one doesn't have a lot of features the other one does," Barney observed. "There's no record or playback volume control, no battery condition indicator, no back-space feature."

"True, but on the other hand it's about half as big as the IBM, weighs about a third as much, records ten times longer, and—" he paused for dramatic effect—"costs about \$80 as compared with over \$400 for the IBM

224. The Memocord comes with a telephone pickup, a combination speaker-mike for conference work, a patchcord, an earphone, and a fitted impact-type plastic case. At extra cost you can get either a sensitive pen-type mike or a miniature 'surveillance type' for increased sensitivity and a foot switch for transcribing. Built-in jacks accept these accessories. IBM accessories are extra.

"Actually, each recorder serves a different need. The IBM is ideal for the businessman who wants it for dictating letters to be transcribed by a secretary. The high-quality audio, the various features designed for the secretary's convenience, and the fact that its belts can be used on standard IBM transcribing equipment make it well worth the extra cost to him.

"On the other hand, the person who wants a dictation recorder chiefly as an easily carried audible notebook to take down ideas and observations on the spot to be digested later will find the Memocord's diminutive size, light weight, and long recording time very appealing, and its modest price outweighs the missing features. I know this much: after playing with the Memocord for the past week and the IBM 224 today, I don't see how I got along without something like this in the past, and I'm determined not to be without a dictation-type recorder in the future!" ▲

### SHORTAGE OF ENGINEERS PREDICTED

**I**n a study of the future supply of engineering graduates just completed by the Engineering Manpower Commission of Engineers Joint Council, the report indicates that current shortages of engineering manpower are liable to continue.

The analysis shows a big gap between engineering degrees awarded in any one year and the number of new engineers actually available for employment. For example, out of about 50,900 degrees in 1966, only 68% or 34,800 individuals will be seeking jobs. The gap, according to the Commission, is due to the increasing number of engineers who are working for advanced degrees.

In addition, the study reveals a steadily declining trend in the popularity of engineering courses not only among all freshmen entering college but also on the part of scholarship winners. The net effect will be little or no increase in the number of new engineers available for employment until 1969. Even by 1974 only 46,400 new engineers can be anticipated. In view of published figures indicating a current demand for 69,000 to 71,000 engineers a year, companies will face severe competition in their efforts to hire all the new graduates they could use.

Since at least 16,000 new engineers are needed each year just to fill vacancies caused by retirement, death, or other losses to the profession, the supply of engineering manpower available to support industrial expansion is still further reduced below what might be assumed from a count of degrees awarded. ▲



FROM HiFi STEREO REVIEW

# DELUXE PADDED DUST-PROOF RECORD AND TAPE CASES

plus FREE cataloging forms



**These decorative, yet sturdily constructed cases are just what you've been looking for**

to keep your records and tapes from getting tossed about and damaged, disappearing when you want them most and just generally getting the "worst of it" from constant handling. They're ideal too for those valuable old "78's" that always seem to get thrown about with no place to go.

Constructed of reinforced fiberboard and covered in rich leatherette in your choice of nine decorator colors, the HiFi/STEREO REVIEW Record and Tape Cases lend themselves handsomely to the decor of any room, whether it be your library, study, den, music room or pine-paneled garage. The padded leatherette back (in your color choice) is gold tooled in an exclusive design available only on HiFi/STEREO REVIEW Record and Tape Cases. The sides are in standard black leatherette to keep them looking new after constant use.

With each Record and Tape Case you order you will receive, free of charge, a specially designed record and tape cataloging form with pressure-sensitive backing for affixing to the side of each case. It enables you to list the record names and artists and will prove an invaluable aid in helping you locate your albums. The catalog form can be removed from the side of the case at any time without damaging the leatherette.

Record Cases are available in three sizes: for 7", 10" and 12" records. Each case, with a center divider that separates your records for easy accessibility, holds an average of 20 records in their original jackets. The Recording Tape Case holds 6 tapes in their original boxes.

● The Tape Cases and the 7" Record Cases (with catalog forms) are only \$3.25 each; 3 for \$9; 6 for \$17.

● The 10" and 12" Record Cases (with catalog forms) are \$3.50 each; 3 for \$10; 6 for \$19.

Add an additional 75c per order (regardless of number of cases ordered) for shipping and handling.

Ziff-Davis Publishing Company, Dept. SD  
One Park Avenue, New York, N. Y. 10016

My remittance in the amount of \$\_\_\_\_\_ is enclosed for the Cases indicated below.

Quantity _____	Tape Case at \$3.25 each; 3 for \$9; 6 for \$17.
_____	7" Record Case at \$3.25 each; 3 for \$9; 6 for \$17.
_____	10" Record Case at \$3.50 each; 3 for \$10; 6 for \$19.
_____	12" Record Case at \$3.50 each; 3 for \$10; 6 for \$19.

Add 75c PER ORDER for SHIPPING and HANDLING  
Check color choice for back of case (sides in black only):

<input type="checkbox"/> Midnight Blue	<input type="checkbox"/> Red	<input type="checkbox"/> Saddle Tan
<input type="checkbox"/> Pine Green	<input type="checkbox"/> Orange	<input type="checkbox"/> Yellow
<input type="checkbox"/> Grey	<input type="checkbox"/> Black	<input type="checkbox"/> Spice Brown

Name \_\_\_\_\_ EW-87

Address \_\_\_\_\_

City \_\_\_\_\_ State \_\_\_\_\_ Zip Code \_\_\_\_\_

**PAYMENT MUST BE ENCLOSED WITH ORDER**

## Value Engineering

(Continued from page 44)

tions resulting from this effort are shared on a pre-negotiated basis with the customer.

The Value Engineering Incentive Provisions do not require any specified amount of effort, are not funded as an item of the contract, but do include provisions for sharing any savings. The contract-sharing benefits that are available under the incentive provisions are more liberal than under the program requirement.

In addition to savings-sharing available on existing (referred to as instant) contracts, provision is made for sharing savings realized on future purchases by the customer as well as other customer collateral savings.

### Future Outlook

Value engineering includes the application of philosophies and principles that are far from new. All have been used by individuals and groups both now and in the past. (This is particularly true in the case of electronics firms which make products for the commercial and consumer markets as contrasted with those whose principal customer has been the U.S. Government.—Editor) What has happened in the past few years is that all of these programs have been coordinated in a number of defense-oriented industries into a useful technique.

As is the case with most new approaches, value engineering has encountered some resistance. Most electronics firms have never seen fit to divorce development design from product design and have continued to handle both functions within the same department. Shorter contract schedules and limited production runs have seemingly justified this approach. Yet it is a fact that it is virtually impossible to handle development and production at the same time, as one area invariably suffers. The experience with government electronics contracts has been that the cost portion of the formula has been the loser as optimum production costs cannot be obtained during the development phase.

On the other hand, value-engineering efforts, especially the cost-target approach, can do much to improve the costs of limited-production items with short development schedules. As competition grows, more companies will discover that the application of value engineering can improve control of product costs and thus improve their market position and their profits. This will only happen if they investigate the tools available and then apply them in the manner which best fits their philosophies.

# HICKOK

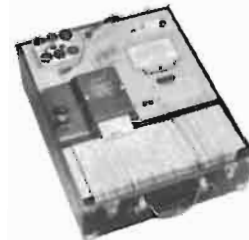

**123R CARDMATIC TUBE TESTER**—Automatic tube testing using card-programmed switch, eliminates errors. A fast, automatic tube tester which includes tests for saturation and cut-off in addition to mutual conductance.

\$655.00



**580A TUBE TESTER**—Entirely new. Can be set up to any test condition, including handbook parameters. Also includes built-in roll chart. Features ultra-sensitive grid condition test with sensitivity to 0.005a.

\$585.00



**539C TUBE TESTER**—Laboratory and industrial instrument. Provides both handbook condition tests and tests "tailored" to specific individual conditions. Roll chart data.

\$545.00



**752A TUBE TESTER**—Communications and industrial maintenance instrument. Includes tests for 4-digit industrial tube types, VR tubes, and low power thyratrons. Best buy for general purpose industrial maintenance. Roll chart data.

\$385.00



**6000A TUBE TESTER**—Service technician's high-speed, portable tester. Tests all popular entertainment types, also transistors and diodes. Time saving leakage and short indicators. Replaceable socket plate for obsolescence protection. Roll chart data.

\$259.50

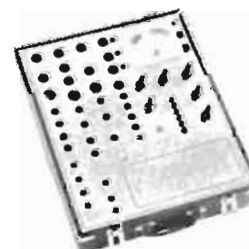

**789 MULTI-SOCKET TUBE TESTER**—Ideal for television service and repair. Provides true mutual conductance tests with no paralleled elements. Solid state sensing circuit provides 50 megohm leakage tests, 0.1µa gas and grid emission tests. Replaceable panel plate for future tube additions.

\$199.95

**THE HICKOK ELECTRICAL INSTRUMENT COMPANY**  
10514 Dupont Avenue • Cleveland, Ohio 44108  
CIRCLE NO. 110 ON READER SERVICE CARD



# Deluxe ELECTRONICS WORLD MAGAZINE CASES

DESIGNED TO HOLD A FULL YEAR'S COPIES



These decorative, yet sturdily constructed cases are just what you've been looking for to keep your copies of *Electronics World Magazine* in easy-to-find order.

Constructed of reinforced fiberboard and covered in rich leatherette, these durable cases guard against soiling and tearing of your magazines while lending themselves handsomely to the decor of any room, whether it be a library, study, den, music room or pine-paneled garage. The magazine cases are available with embossed gold lettering in either all black or attractive maroon back with black sides.

Specially designed to hold a full year's copies of *Electronics World Magazine*, the cases are only

**\$3.50 ea., 3 for \$10, 6 for \$19**  
**FULLY GUARANTEED**

NOTE: Magazine cases are also available for other of your favorite titles. For prompt shipment, use the coupon below.

Ziff-Davis Publishing Company, Dept. SD  
One Park Avenue, New York, N.Y. 10016

Please send \_\_\_\_\_ *Electronics World Magazine* Cases. Also send cases for the magazine titles indicated below:

TITLE	QUANTITY
_____	_____
_____	_____
_____	_____

- All black, gold embossed  
 Maroon back, gold embossed/black sides

Enclosed is \$ \_\_\_\_\_ at \$3.50 per case, 3 for \$10, 6 for \$19 (Quantity prices apply for combination orders of more than one title). Orders outside U. S. A. \$4.50 ea., 3 for \$13, 6 for \$25.

Name \_\_\_\_\_ EW-87  
Address \_\_\_\_\_  
City \_\_\_\_\_  
State \_\_\_\_\_ Zip Code \_\_\_\_\_

Payment must accompany order.

## RADIO & TV NEWS

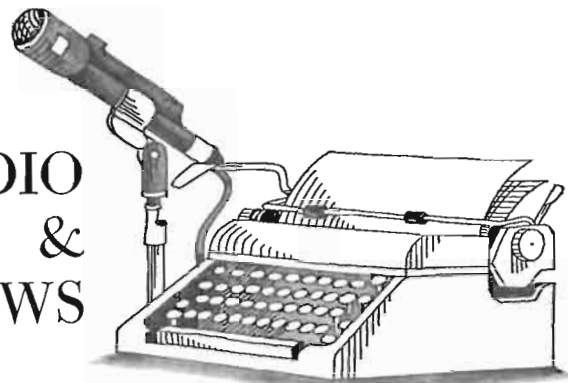

ONE of the most fascinating electronic operations in history was the reproduction of high-resolution TV pictures taken on the moon and relayed the quarter-million miles to Earth.

Part of the complex electronic pickup equipment was an image enhancer that sharpened up the fine details on the received lunar pictures.

Until now, this detail-enhancing technique was performed with the aid of computers at the ground stations.

Now *CBS Labs.* has developed a new approach to electronic image enhancement that it claims will produce sharper, more detailed transmission of commercial television. This new device will compare and increase the contrast of each individual point of information on the TV picture, in both the vertical and horizontal directions. As a result, both color and monochrome receivers in the home will display sharper pictures.

In effect, the new enhancer has what can be called a short-term memory bank. A pair of ultrasonic delay lines in the device retains the picture information long enough to compare every point in the picture with all of the points surrounding it. The contrast between these points is then automatically emphasized and, at the same time, noise (or non-picture information) is eliminated.

### Air Pollution and TV

We have been hearing a lot lately on how air pollution is affecting our breathing, dirtying up our clothes and cities, and generally making a nuisance of itself. What we didn't guess was its effect on TV reception.

According to Everett Wollman, President of *Injectorall Electronics Corp.*, "In the past, TV tuners suffered from the usual accumulation of dust and grime, but now two additional factors have entered to complicate the problem. The first of these has been the extension of tuner range to cover the u.h.f. bands. At these frequencies, dirt that might present a borderline problem at the lower v.h.f. now becomes a serious problem.

"The dirty tuner problem has also

been complicated by growing air pollution. The high sulfur level in the atmosphere has resulted in a much stronger acidic air content. All TV tuners are exposed to the attack of this non-neutral air, resulting in microscopic pitting and lower conductivity in tuner elements, plus increased resistance or intermittent resistance in sliding contacts."

### Laser-Pumped Lasers

Since the inception of lasers, most of them have either been excited by r.f., heavy current flow, or were pumped by an intense white light.

Now scientists at the *Korad Corp.* have successfully used one laser to pump another to produce an output in a part of the optical spectrum heretofore difficult to attain.

In particular, they have been successful in lasing such solutions of organic dyes as fluorescein, Rhodamine, and Acriflavin-hydrochloride by using the second harmonic of both ruby and neodymium-glass lasers. These organic dyes cannot be pumped directly by either the ruby or glass output bursts because their absorption bands are in the ultraviolet and blue-green where these lasers are weak. Argon-ion lasers, which emit directly in the blue-green, are too weak to serve as a pumping source.

The scientists used a *Korad* laser equipped with an ammonium-dihydrogen-phosphate frequency multiplier to generate the second harmonic.

This phenomenon, which has not previously been reported, may provide a useful method for the study of intramolecular cross-relaxation processes.

### Electronics Business News

According to the latest figures issued by the U.S. Department of Commerce, U.S. exports of electronic products in 1966 reached a record \$1.2 billion. This is up 24.9% from 1965.

Radio and TV broadcast transmitters, associated audio equipment, microwave systems, and computers and accessories accounted for nearly 50%. Principal markets for the computers were the European Economic Community (\$106.2

million), Canada (\$48.7 million), United Kingdom (\$46.8 million), and Japan (\$33.6 million).

Exports of TV sets and chassis hit \$40 million with Canada taking \$17.5 million, Venezuela \$3.2 million, Mexico \$2.5 million, and Ireland \$1.6. ▲

## SOME COLOR-TV SETS MAY EMIT SOFT X-RAYS

**T**HE General Electric company has announced a program to modify some of its large-screen color-TV sets because quality control tests show that some of the sets produced between June of 1966 and February of 1967 may emit soft x-rays in excess of desirable level. When present, this emission is directed towards the floor and not towards the viewer. The picture tube is not involved.

Nationally recognized radiological health experts have confirmed preliminary company findings that emissions have not been sufficient to cause any harm to the viewer.

No black-and-white sets, no Porta-Color sets, and no sets purchased before June 1966 are involved.

The modification involves replacement of the high-voltage regulator tube and adjustment of the power supply.

Owner identification is being achieved through mobilization of G-E's entire distributor-dealer organization. Factory records, dealer sales records, warranty cards, service records, and contracts and finance records are among the many sources being used to derive this information.

Set owners may contact their dealer or technician if the modification has not been completed by July 1, 1967.

Mr. James G. Terrill Jr., director of the National Center for Radiological Health in Rockville, Md., said "As of now, there is no evidence in the hands of the National Center to suggest that any TV receivers manufactured by the General Electric Company, or that sets made by other companies, have excessively exposed viewers of TV sets."

Because the radiation emanating from the sets is directly down under the set, Mr. Terrill finds it hard to visualize any way in which a TV viewer could get exposed to enough radiation from such a set so as to constitute a health hazard.

He also said that it is impossible to put any meaningful figure on the amount of radiation exposure to be expected because this would vary greatly with the circumstances.

The radiation is emitted directly downward in a thin crescent pattern and at a range of about one foot below the set, would be about the size and shape of the crescent a man could make with his thumb and forefinger. At a greater range, the crescent would be bigger, but the radiation would be weaker.

It is estimated that a person would have to spend 40 cumulative hours directly under the set to make the skin red. Sets resting directly on the floor probably pose no radiation hazard. ▲

# ORGANIZE! DO IT NOW!



**MAGNETIC VISUAL CONTROL  
BOARDS SIMPLIFY WORK  
COLORFUL**

**MAGNETIC ELEMENTS**

- show facts instantly
- organize for action
- eliminate mistakes
- get the job done

**MAGNETS MOVE FASTEST—  
AND EASIEST—OF ALL**

**WRITE FOR FREE 28 PAGE  
ILLUSTRATED CATALOG EW8**

**METHODS RESEARCH CORP. • 24 WILLOW AVE., STATEN ISLAND, N.Y. 10305**

CIRCLE NO. 199 ON READER SERVICE CARD

## Electronics World SUBSCRIBER SERVICE

Please include an address label when writing about your subscription to help us serve you promptly. Write to: Portland Place, Boulder, Colorado 80302

### CHANGE OF ADDRESS:

Please let us know you are moving at least 4 to 6 weeks in advance. Affix magazine address label in space to the right and print new address below. If you have a question about your subscription, attach address label to your letter.

**TO SUBSCRIBE:** Check boxes below.

- New       Renewal  
 5 years \$21    3 years \$15    1 year \$6

**SPECIFY:**  Payment enclosed—You get 1 extra issue per year as a bonus!  Bill me later.

If you have no label handy, print OLD address here.

name \_\_\_\_\_ please print  
 address \_\_\_\_\_  
 city \_\_\_\_\_  
 state \_\_\_\_\_ zip-code \_\_\_\_\_

**AFFIX LABEL HERE**

(Add'l postage: \$1 per year outside U.S., its possessions & Canada.)

name \_\_\_\_\_ please print \_\_\_\_\_ 0170

address \_\_\_\_\_

city \_\_\_\_\_

state \_\_\_\_\_ zip-code \_\_\_\_\_

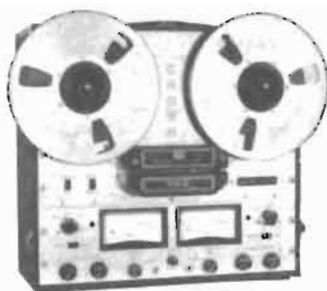

MODEL 1/4 TRACK STEREO **WORLD STATE**  
**SX724 ONLY \$995**

**NEW!**

**Modular Transport  
Low-Noise Circuitry  
Third Head Monitoring**

*World's Finest Recording Quality*

Speed	Response	S/N
7-1/2	±2db 30 to 25,000	55db
3-3/4	±2db 30 to 15,000	50db

**Crown International  
BOX 1000, DEPT. EW-8  
ELKHART, INDIANA**

**MADE ONLY IN AMERICA**

CIRCLE NO. 121 ON READER SERVICE CARD

when it's time to think of college  
you should read this

**FREE CAREER BOOKLET**



about electronics at

**MSOE**

**MILWAUKEE SCHOOL OF ENGINEERING** MS-235  
 Dept. EW-867 1025 N. Milwaukee Street  
 Milwaukee, Wisconsin 53201

Tell me about an engineering career through residence study in:

- Electrical fields     Mechanical fields

Name.....Age.....

Address.....

City, State.....

CIRCLE NO. 105 ON READER SERVICE CARD



# SOMEONE SHOULD DEVELOP AN EASY WAY TO LEARN ELECTRONICS AT HOME



## RCA INSTITUTES DID!

Here is a whole new approach to learning electronics at home! RCA Institutes, one of the nations' largest schools devoted to electronics, has developed a faster, easier way for you to gain the skills and the knowledge you need for the career of your choice. Here for the first time, is a student-proved, scientifically designed way to learn. If you have had any doubts in the past about home training in electronics—if you have hesitated because you thought you might not be able to keep up—or that electronics was too complicated to learn—here is your answer! Read how RCA Institutes has revolutionized its entire home training ideas!

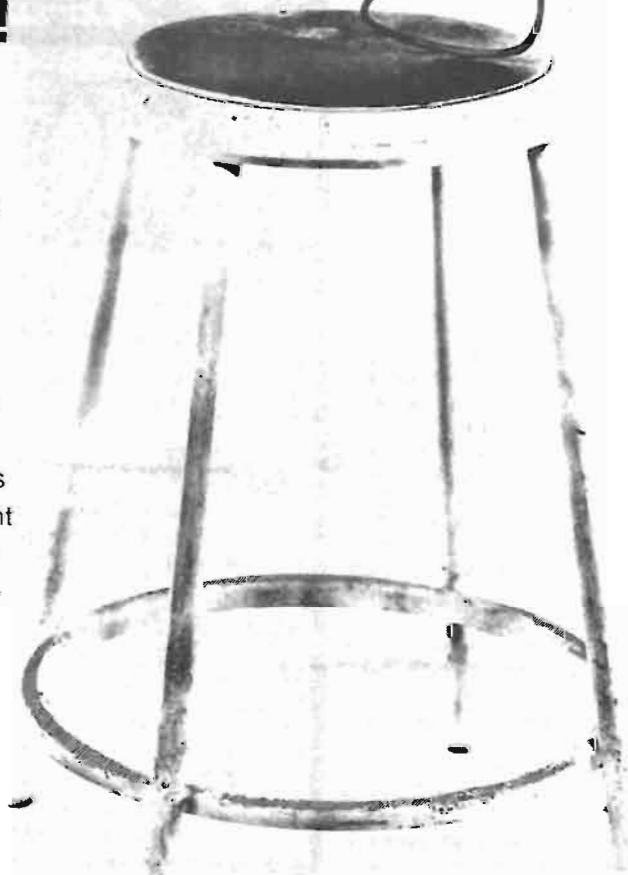

# NEW CAREER PROGRAMS BEGIN WITH "AUTOTEXT" INSTRUCTION METHOD!

Start to learn the field of your choice immediately!

No previous training or experience in electronics needed!

With this new revolutionized method of home training you pick the career of your choice—and RCA Institutes trains you for it. RCA's Career Programs assure you that everything you learn will help you go directly to the field that you have chosen! No wasted time learning things you'll never use on the job! The Career Program you choose is especially designed to get you into that career in the fastest, easiest possible way!

And each Career Program starts with the amazing "AUTOTEXT" Programmed Instruction Method—the new, faster way to learn that's almost automatic! "AUTOTEXT" helps even those who have had trouble with conventional home training methods in the past. This is the "Space Age" way to learn everything you need to know with the least amount of time and effort.

## CHOOSE A CAREER PROGRAM NOW

Your next stop may be the job of your choice. Each one of these RCA Institutes Career Programs is a complete unit. It contains the know-how you need to step into a profitable career. Here are the names of the programs and the kinds of jobs they train you for. Which one is for you?

**Television Servicing.** Prepares you for a career as a TV Technician/Serviceman; Master Antenna Systems Technician; TV Laboratory Technician; Educational TV Technician.

**FCC License Preparation.** For those who want to become TV Station Engineers, Communications Laboratory Technicians, or Field Engineers.

**Automation Electronics.** Gets you ready to be an Automation Electronics Technician; Manufacturer's Representative; Industrial Electronics Technician.

**Automatic Controls.** Prepares you to be an Automatic Controls Electronics Technician; Industrial Laboratory Technician; Maintenance Technician; Field Engineer.

**Digital Techniques.** For a career as a Digital Techniques Electronics Technician; Industrial Electronics Technician; Industrial Laboratory Technician.

**Telecommunications.** For a job as TV Station Engineer, Mobile Communications Technician, Marine Radio Technician.

**Industrial Electronics.** For jobs as Industrial Electronics Technicians; Field Engineers; Maintenance Technicians; Industrial Laboratory Technicians.

**Nuclear Instrumentation.** For those who want careers as Nuclear Instrumentation Electronics Technicians; Industrial Laboratory Technicians; Industrial Electronics Technicians.

**Solid State Electronics.** Become a specialist in the Semiconductor Field.

**Electronics Drafting.** Junior Draftsman, Junior Technical Illustrator; Parts Inspector; Design Draftsman Trainee Chartist.

## SEPARATE COURSES

In addition, in order to meet specific needs, RCA Institutes offers a wide variety of separate courses which may be taken independently of the Career Programs, on all subjects from Electronics Fundamentals to Computer Programming. Complete information will be sent with your other materials.

## LIBERAL TUITION PLAN

RCA offers you a unique Liberal Tuition Plan—your most economical way to learn. You pay for lessons only as you order them. No long term contracts. If you wish to stop your training for any reason, you may do so and not owe one cent until you resume the course.

## VALUABLE EQUIPMENT

You receive valuable equipment to keep and use on the job—and you never have to take apart one piece to build another. New—Programmed Electronics Breadboard. You now will receive a scientifically, programmed electronic bread-

board with your study material. This breadboard provides limitless experimentation with basic electrical and electronic circuits involving vacuum tubes and transistors and includes the construction of a working signal generator and superheterodyne AM Receiver.

**Bonus From RCA—Multimeter and Oscilloscope Kits.** At no additional cost, you will receive with every RCA Institutes Career Program the instruments and kit material you need to build a multimeter and oscilloscope. The inclusion of both these kits is an RCA extra.

## CLASSROOM TRAINING ALSO AVAILABLE

RCA Institutes maintains one of the largest schools of its kind in New York City where classroom and laboratory training is available in day or evening sessions. You may be admitted without any previous technical training; preparatory courses are available if you haven't completed high school. Coeducational classes start four times a year.

## FREE PLACEMENT SERVICE

In recent years, 9 out of 10 Resident School students who used the Free Placement Service had their jobs waiting for them when they graduated. And many of these jobs were with top companies in the field—such as IBM, Bell Telephone Labs, General Electric, RCA, and radio and TV stations and other communications systems throughout the world.

**SEND ATTACHED POSTAGE PAID CARD FOR COMPLETE INFORMATION, NO OBLIGATION. NO SALESMAN WILL CALL.**

**ALL RCA INSTITUTES COURSES  
AVAILABLE UNDER NEW GI BILL.**

**RCA INSTITUTES, Inc.,** Dept. EW-87  
A Service of Radio Corporation of America  
350 West 4th St., New York, N.Y. 10014



**The Most Trusted Name in Electronics**



# TEST EQUIPMENT

## PRODUCT REPORT

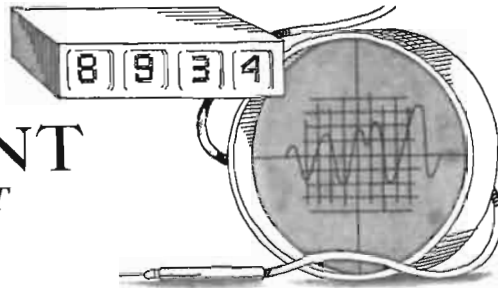

### "Knight-Kit" Model KG-663 Regulated D.C. Power Supply

For copy of manufacturer's brochure, circle No. 31 on Reader Service Card.



An entire new line of test equipment is being marketed by Allied Radio. As we see it, the line has two main distinguishing features: first, it is professional in appearance and design; and second, it uses all-solid-state electronics. The first piece of equipment in the line is the Model KG-663 d.c. power supply.

This is no ordinary 40-volt, 1.5-ampere adjustable supply, as may be seen by examining the block diagram shown here. Rather it is a highly stable, low-ripple, closely voltage-regulated, and current-limited supply that would serve as an excellent power source for transistor circuit development and servicing in the laboratory, classroom, and service shop and on the production line.

The output voltage can be adjusted very accurately by means of concen-

tric coarse and fine front-panel controls to any value from zero up to 40 volts maximum. Also, there is a continuously variable current-limiting control that automatically limits short-circuit current to a safe, preset value up to 1.5 amperes. The output terminals are fully isolated so that either positive or negative grounding may be used. A pair of meters on the front panel monitors output voltage and current at all times. If the supply is to be located at some distance from the circuit being powered, it is possible to adjust its setting and get it to regulate for variations in the load from the remote location.

The circuit consists of six transistors and eleven diodes. The diodes are used for rectification, voltage-reference purposes, and reverse-voltage protection. The transistors serve to detect any change in output voltage, amplify it, and apply it to a pair of series pass power transistors (Q5 and Q6) whose emitter-to-collector resistance is varied to compensate for the voltage change and bring the voltage back to its preset value. In the event of excess current, transistor Q1 is turned on. It then takes control away from the error detector and shunts down the pass transistors to where a safe current is maintained.

The KG-663 power supply is priced at \$99.95 in kit form or \$149 factory-assembled. ▲

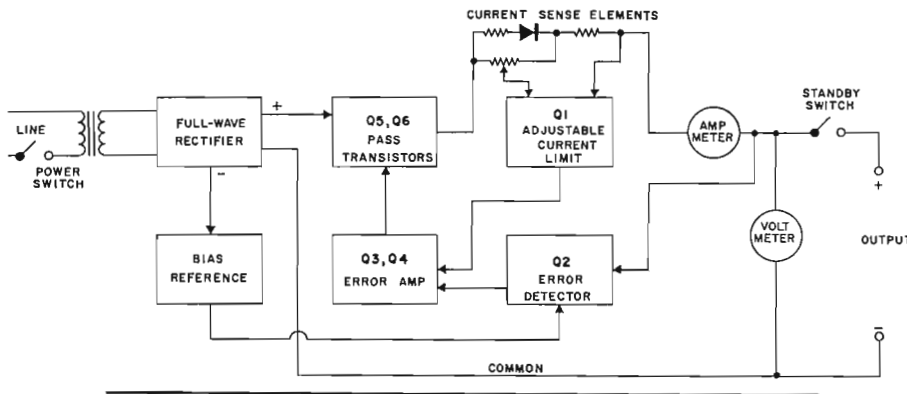

### Triplet Model 600 Transistorized V.O.M.

For copy of manufacturer's brochure, circle No. 32 on Reader Service Card.

At first glance, the new Triplet Model 600 looks like a very attractively styled but conventional v.o.m. True, it

has a couple of extra very low voltage ranges (0.4 and 0.8 volt) for transistor-equipment servicing, but other v.o.m.'s

have such ranges, too. When one studies the specs, however, and examines the circuit, then the real value of the new meter becomes apparent. By using a field-effect transistor (with its very high input impedance) in cascade with a conventional transistor (with its low output impedance), the manufacturer has given the v.o.m. the advantages of a v.t.v.m. Further, since transistors are used rather than tubes, the circuit can



be powered by a few penlight cells and a transistor-radio battery (see diagram). Hence, the instrument need not be plugged into an a.c. outlet and it retains the portability of a v.o.m. along

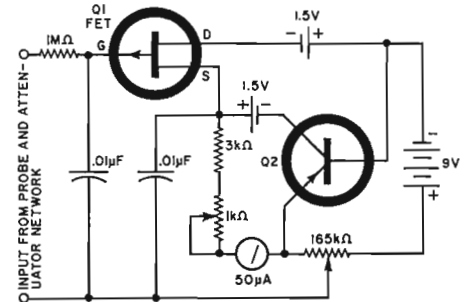

with the high input impedance of a v.t.v.m.

Designed for use by service technicians, instrument and electronic process control engineers, test laboratory and computer system technicians, and quality-control and manufacturing technical personnel, the new transistorized Model 600 has an 11-megohm input impedance on d.c. and an accuracy of  $\pm 3\%$  of full scale on both a.c. and d.c. ranges.

The new case design is quite striking, with its brushed-aluminum front panel and etched black range markings. The extruded aluminum carrying handle permits the meter to be tilted up from the bench by about 25° for easy reading. The removal of one large slotted thumbscrew on the back of the case permits convenient battery replacement and easy access to the circuit components that are mounted within the case of the instrument.

Typical battery life is 4000 hours of

operation in normal use, which approximates shelf life. Also, all batteries used are readily available, inexpensive types

(one "D" cell, two "AA" cells, and one 9-volt transistor battery). The price of the Model 600 is \$78.

### Sencore MU-140 Tube Tester

For copy of manufacturer's brochure, circle No. 33 on Reader Service Card.

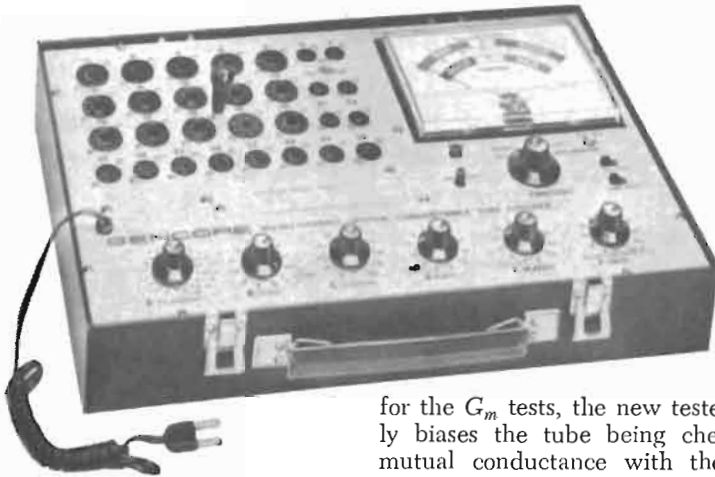

**D**ESPITE the widespread use of transistors in consumer electronics equipment, there are still plenty of vacuum tubes in equipment that is not about to be scrapped by satisfied users. What is more, new color-TV receivers and small industrial electronics equipment will be using tubes, particularly the new compact multiple-purpose types, for a good many years to come. The new Sencore MU-140 "Commander" provides the means for checking these tubes. It is designed to give a qualitative check by measuring the actual mutual conductance of the tubes it tests. Hence, the instrument can be used in laboratories and broadcast stations, and for incoming inspection, production-line testing, and quality control in electronics manufacturing.

Featuring an automatic biasing system and the use of 5-kHz square waves

for the  $G_m$  tests, the new tester actually biases the tube being checked for mutual conductance with the correct bias voltage at the current selected for the plate circuit. This eliminates a set-up control and reduces possible errors in set-up and readings.

In checking power amplifiers and rectifiers, the MU-140 draws actual rated cathode current from the tube under test to measure its current-emitting capabilities. The new tube tester also provides high-sensitivity grid-leakage and interelement-shorts tests.

Capable of checking all TV and radio tubes, including novars, compactons, nuvistors, magnovals, and foreign tubes, the instrument also provides space for additional sockets to accommodate future tubes with different base arrangements. Protection against obsolescence is thus assured.

The sturdy attaché case is made from mar-resistant vinyl-clad steel. The tester, with its up-to-the-minute tube chart, is priced at \$179.50.

### Biasing in Tape Recording

(Continued from page 36)

caused by irregularities in the tape coating; it is therefore very much a function of the tape quality.

When the bias is a.c.-coupled to the recording head, any average d.c. is eliminated. Unfortunately, the peak bias amplitude may still be asymmetrical and this leaves a d.c. flux on the tape.

The bias oscillator circuit shown in Fig. 4 is a common astable multivibrator circuit with a center-tapped transformer, in place of the normal collector resistors and a capacitor, added to complete the parallel resonant circuit with the transformer. This tuned circuit not only sets the frequency of oscillation but also makes the signal sinusoidal. Because the circuit is push-pull, the

even-order harmonics, which will cause distortion and noisy recordings, are greatly reduced. The emitter resistors are added to balance the gain in the two transistors to further reduce the generation of even harmonics.

Fig. 4. A typical bias-oscillator circuit using transistors.

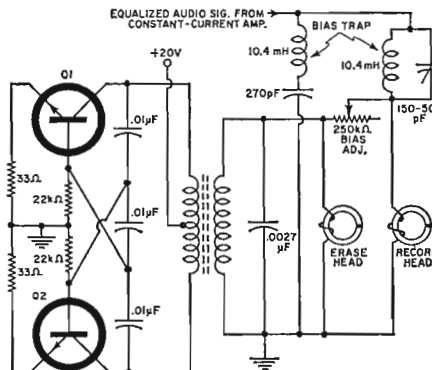

**ALL NEW!**



These are the men who made the headlines in 1966—the top drivers who walked off with the big prizes! And this year, there's a new headline-maker that's required reading for racing enthusiasts! It's the CAR and DRIVER RACING ANNUAL—the first one ever published!

It contains complete box scores of every major event in this country and abroad, including order of finish, equipment and official times . . . over a dozen feature stories of individual races—Indy, Daytona, LeMans, Watkins Glen, the National Drags—all of them . . . plus the champions of the year, FIA, SCCA, NASCAR and USAC winners, and personality wrap-ups on the top drivers in every category of racing.

The RACING ANNUAL is an almanac of competition information covering the entire year of 1966—as a reference book it's the finest, most complete manual of its kind—as a thriller, it brings every suspenseful heat back to life with lavish use of dramatic photos, and words that spell "speed" from start to finish!

Better order yours now . . . without the RACING ANNUAL, you're buried at the starting line. With it, you're really with it! Use the coupon below to get your copy with the utmost speed—after all, speed is what you're going to get!

GET THE HANDSOME LEATHERFLEX-BOUND EDITION for just \$3 POSTPAID! The CAR and DRIVER RACING ANNUAL is also available in a splendid deluxe edition. Rugged Leatherflex cover provides lasting protection yet is softly textured and gold-embossed for the look of elegance. A collector's item—a superb addition to your permanent automotive reference library. And it's yours, for just \$3 postpaid, when you check the appropriate box on the order form.

ZIFF-DAVIS SERVICE DIVISION • DEPT. RA  
595 Broadway, New York, N.Y. 10012  
YES! Send me the new CAR and DRIVER RACING ANNUAL.  
 \$1.25 enclosed, plus 15c for shipping and handling. Send me the regular edition. (\$1.75 for orders outside the U.S.A.)  
 \$3.00 enclosed. Send me the Deluxe Leatherflex-bound edition, postpaid. (\$3.75 for orders outside the U.S.A.) Allow three additional weeks for delivery.

name  please print  EW-87  
address   
city   
state  zip code   
**PAYMENT MUST BE ENCLOSED WITH ORDER**



# Bias Compensation for TRANSISTOR OUTPUT STAGES

By PATRICK HALLIDAY

*Circuits recommended by British manufacturers to minimize crossover distortion in class-B type transistor audio stages.*

**T**HE bias applied to the class-B push-pull output stages of transistor devices has to be reasonably accurately determined to avoid crossover distortion. However, it is difficult, using conventional resistor networks, to avoid some degree of crossover distortion as the battery voltage falls, particularly in low ambient temperatures. This problem has long been recognized and has resulted in the development of compensation techniques designed to automatically adjust the bias conditions to changes in battery voltages and/or ambient temperature. Two effective techniques involve the use of either temperature-sensitive thermistors or junction diodes.

## Crossover Distortion

Crossover distortion in a transistor class-B stage arises when the bias conditions, or any substantial difference in the characteristics of the output pair, result in discontinuities at the changeover point so that the two half-cycles of the amplified waveform do not accurately fit together. Fig. 1 shows two common forms in which this type of non-linearity distortion takes place.

This distortion is highly objectionable to the listener as it produces high-order harmonics resulting in discordant speech or music. Provided that a well-matched pair of transistors is used, crossover distortion can be kept low by careful choice of bias current arranged so that there is appreciable idling current flowing under no-signal conditions;

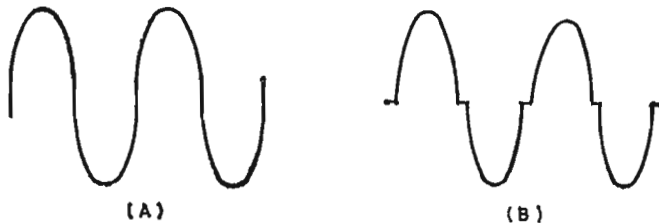

Fig. 1. Crossover distortion may take these forms in class-B transistor amplifiers. In (A), the sine waves have straight sides in the area on both sides of the zero crossover point.

therefore, the stage is not operating in true class B. Negative feedback is also valuable in reducing this form of distortion.

When the bias network is made up of conventional resistors, these are often specified as 5% tolerance to ensure that the bias current is close to design optimum. Split-load output stages have also been used to reduce the effects of crossover distortion.

With most non-compensated output circuit arrangements, the designer has the difficult problem of choosing a bias condition that will suit the stage when it is operated from a new battery or at the much lower end-point voltage of dry zinc-carbon cells. The problem would be much less acute if mercury cells were universally employed, since these maintain almost constant voltage throughout the greater part of their useful life.

If the designer chooses the bias conditions to keep crossover distortion low throughout a wide variation of supply voltage, it is necessary to make the idling no-signal current high at full voltage. This is not only uneconomical for the user but also increases the possibility of thermal runaway.

On the other hand, a moderate idling current at initial battery voltage usually results in crossover distortion becoming objectionable while there is still a lot of potentially useful energy left in the battery. In many transistor receivers, it is the onset of considerable crossover distortion that indicates to the user that a new battery must be installed.

With portable receivers designed to provide some 400 mW of continuous output power, crossover distortion can usually be reduced to an acceptable figure for as long as there is an idling no-signal collector current of about 1 mA for each transistor.

A change in ambient temperature also affects the situation because of the thermal sensitivity of germanium transistors. Crossover distortion will tend to be accentuated at low temperatures since collector current for any one level

Fig. 2. (A) Typical biasing network using 5% tolerance resistors. (B) Temperature-compensated biasing network using a thermistor. (C) Using a germanium junction diode (or diode-connected transistor) for voltage and temperature compensation.

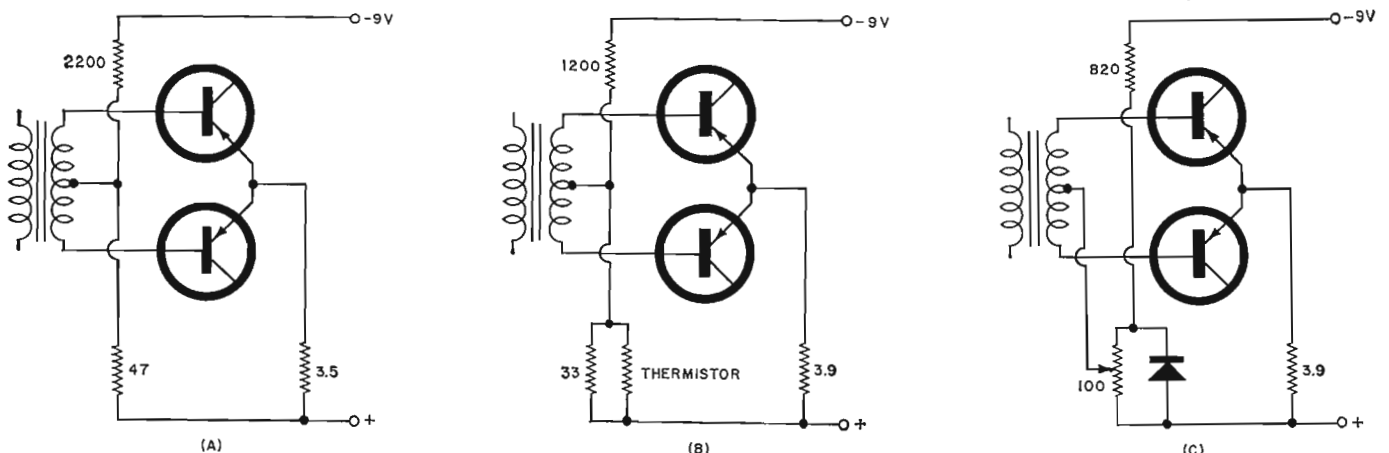

**Fig. 3.** How the no-signal collector current changes with supply voltage for both types of bias networks. These curves are based on a diode current of 9 mA. The shaded portion shows region in which crossover distortion is likely to occur. →

of base-emitter voltage decreases with falling ambient temperature in the area of the transistors.

### Thermistors

The need to change bias conditions with temperature soon led to the use in the bias network of thermistors—semiconductor resistors having a high negative temperature coefficient. Any fall in ambient temperature causes the resistance of the thermistor to rise appreciably, and with good design this can be made to compensate the bias current to the transistor. Fig. 2A shows a simple form of resistor bias network, while Fig. 2B indicates how a thermistor may be incorporated. With compensation, there will usually be some increase in battery wastage due to additional current in the bias network, but the advantages generally outweigh this disadvantage.

### Diodes

Selenium diodes having a non-linear voltage/current relationship have been used in some receivers to adjust the bias current automatically as battery voltage falls.

Although these two individual techniques can provide either temperature or voltage compensation, more recently an effective means of combining both functions within a single component has been developed. This technique uses a small semiconductor junction diode (or a transistor diode-connected by using only the base and collector leads, leaving the emitter lead disconnected). The junction diode is usually germanium, although somewhat more effective compensation can be obtained by using silicon diodes in this circuit.

When a junction diode is connected in the bias network, two useful effects come into play. First, its non-linear voltage/current relationship means that voltage across the diode falls more slowly than the current flowing through it, and in a bias network, the current will be roughly proportional to the supply voltage. Second, the voltage across the diode will decrease with rising temperature.

Of particular value, the non-linear voltage/current relationship of the junction diode corresponds to that of the output transistors, and this allows an almost linear relationship to be achieved between the no-signal collector current of the output transistors and the diode current. Fig. 2C shows how a junction diode can be connected into a bias network to provide voltage and temperature compensation.

From Fig. 3, it can be seen that with the help of a compensating germanium diode, a typical output stage using a nominal 9-volt battery could be expected to operate satisfactorily to below 4 volts without reducing the total no-signal collector to below 2 mA, whereas, with a conventional resistor bias network, the current falls to this figure when the supply voltage reaches 7.3 volts. Furthermore, these results can be achieved with the same initial no-signal current of 2.5 mA for each transistor.

In general terms, with germanium bias-compensating junction diodes, battery voltage can fall to below half its nominal value before performance is likely to drop below acceptable levels, even at low temperatures.

The compensating diode is, of course, affected by temperature in a parallel manner to the output transistors, and in a typical class-B output stage, the circuit can be arranged to at least halve the over-all effect of temperature changes.

In the typical compensated circuit of Fig. 2C, the diode is connected across a preset potentiometer to allow the stage to be set up to suit the particular component and semiconductor tolerances. The potentiometer must be of a value which will keep input losses low without shunting too

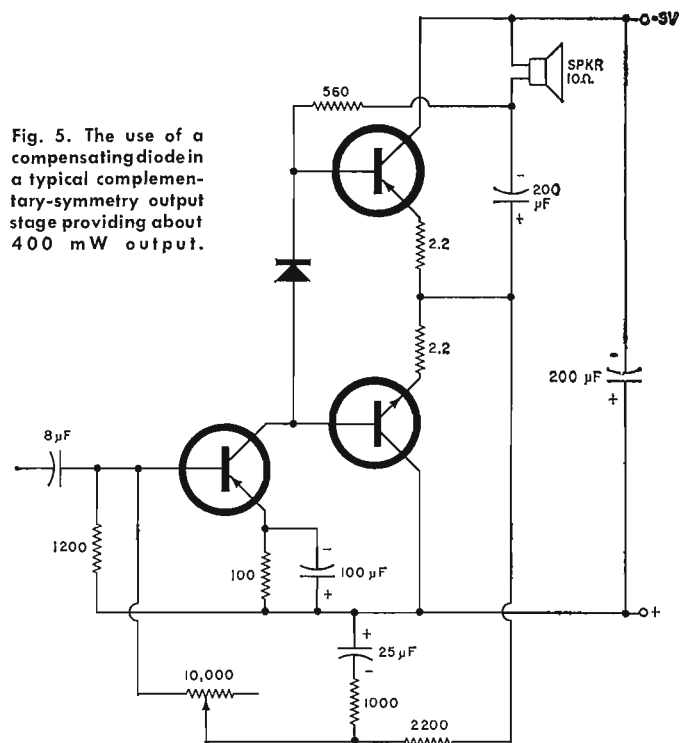
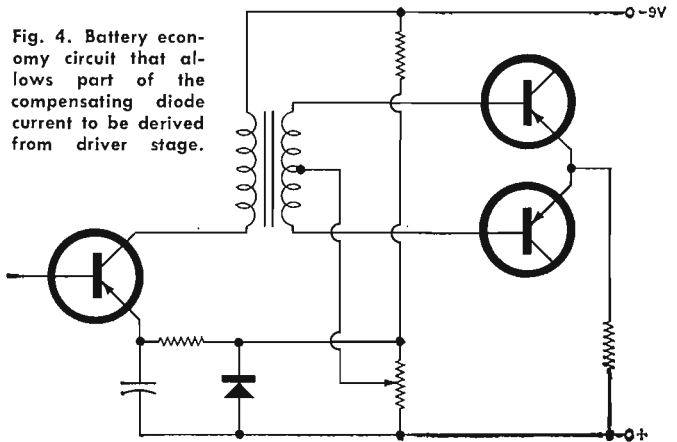
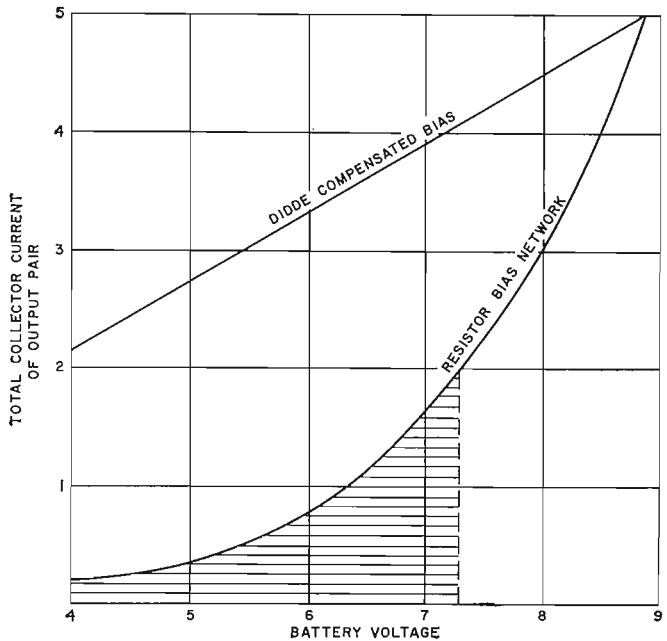



# GAS WELDING TORCH



Uses **OXYGEN**  
and **LP GAS**

- Completely self-contained.
- Produces 5000° pin-point flame.
- Welds, brazes, solders.
- Hundreds of lightweight uses.
- Suggested list — \$19.95.

GET COMPLETE DETAILS AT MOST INDUSTRIAL DISTRIBUTORS, OR WRITE TO MICROFLAME, INC.



**MICROFLAME, INC.**

7800 COMPUTER AVENUE  
MINNEAPOLIS, MINNESOTA 55424

CIRCLE NO. 106 ON READER SERVICE CARD



## A SELECTION OF ANNUALS STILL AVAILABLE

FROM THE WORLD'S LARGEST PUBLISHER OF SPECIAL INTEREST MAGAZINES



### CAR & DRIVER YEARBOOK

A complete buyers guide covering virtually every car available in the United States . . . Road tests . . . Technical specifications . . . Accessories and performance equipment buying guide . . . Guide to racing with action-packed photos.

1967 — \$1.50.....#40  
1966 — \$1.25.....#15  
1965 — \$1.25.....#17



### PHOTOGRAPHY DIRECTORY

World's most complete photographic buying guide.

1967 — \$1.25.....#41  
1966 — \$1.25.....#22



### TAPE RECORDER ANNUAL

Everything you need to know about tape recording including a complete directory of mono and stereo recorders.

1967 — \$1.25.....#42  
1966 — \$1.25.....#30  
1965 — \$1.00.....#31



### STEREO/HI FI DIRECTORY

Complete buyers guide for virtually every Hi Fi component manufactured.

1967 — \$1.25.....#45  
1966 — \$1.25.....#29

Order by number from Ziff-Davis Service Division, 595 Broadway, N.Y., N.Y. 10012. Enclose add'l 15¢ per copy for shipping & handling (50¢ for orders outside U.S.A.)

much of the forward bias current flowing through the diode. Diode current must be in the region of 8 mA for proper operation.

Current flowing through the bias network represents drain on the battery. This wastage can be reduced by obtaining some of the diode current from the emitter current of the driver stage, as shown in Fig. 4.

A further benefit is obtained from a compensating diode used in a transformerless complementary-symmetry output stage of the type shown in Fig. 5. Because of the low a.c. resistance of the diode, any changes in current in the driver stage produce less effect on the output stage than would conventional biasing resistors. In a typical circuit, the use of a diode rather than a circuit where the differential a.c. resistance and d.c. resistance are the same can reduce bias changes due to driver current variations to less than one-fifth.

Thus, in this case, the bias-compensating diode reduces the effects of variations in signal, temperature, and supply voltage upon the bias conditions of the output stage. Because of the varying load of a class-B stage, voltage stabilization is important with power-line-operated as well as battery-operated equipment.

### Other Arrangements

A different form of bias stabilization, which has been used in some radio receivers, is shown in Fig. 6. Here the bias current applied to the push-pull output transistors (Q3 and Q4) is determined by the collector-emitter voltage of stabilizing transistor Q5. This in turn depends upon the base-emitter voltage derived across the 12-ohm resistor which, with the 470-ohm resistor, forms part of a voltage divider in the emitter circuit of driver stage Q2. Any voltage change in the emitter of Q2 will result in a corresponding change in the control voltage applied to the base of Q5. The effects of temperature variations are compensated by a change in the base-emitter voltage of Q5. Supply-voltage variations are similarly compensated by the change in the emitter current of Q2.

By using compensation techniques, the onset of the unpleasant-sounding crossover distortion can be postponed to well beyond the voltage and temperature limits possible in uncompensated output stages.

A number of the diagrams shown in this article are derived from reports of the British firms *Thorn-AEI Radio Valves and Tubes Ltd.* and *Mullard Ltd.*, both of whom have introduced small junction diodes (types AA120 and AA129) for this application. ▲

Fig. 6. Transistor bias stabilization circuit in which bias of the push-pull output stage is determined by the collector-emitter voltage presented across control transistor Q5.

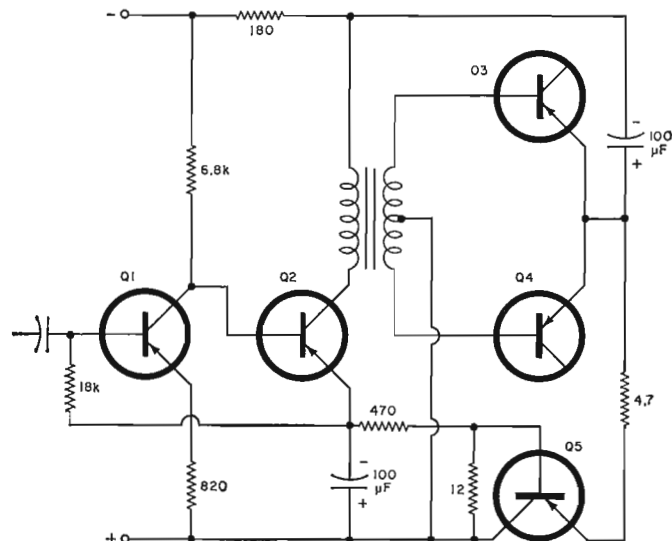

## Magnetic Sound Recording Tapes

(Continued from page 31)

the same principle. Economy is the motto with such tape which apparently is aimed at the youth market.

Cassette tape is used in the Philips type reel-to-reel cartridge. The cassette uses a tape 150-mils wide which can accommodate four recorded tracks (or two stereo pairs). Operating speed of the machine is 1 1/2 in/s, but it is capable of a rather wide response range with a good tape (Fig. 10). The tape required is of the triple-play family but with special steps taken to improve high frequencies and signal-to-noise ratio. The cassette can use the triple or quadruple type tapes for 60 and 90 minutes of operation, respectively.

### Unbranded or "White-Box" Tape

"White-box" tape is the industry term for unbranded or unidentified tape that is normally sold at low price. The tape inside may be a rejected product from a well-known producer or a tape made especially for the white-box trade by some unknown concern. As a rule, it will be a tape which does not fit into the normal product line of a given manufacturer.

Some tapes sold in white boxes may be of high quality and, therefore, real bargains. They may come from:

1. Experimental runs, often of superior quality, but too different from standard products.

2. Computer or instrumentation tapes, rejected for dropouts or other shortcomings which will not affect sound recording.

3. First-line sound tapes downgraded for minor shortcomings, for example, the thickness being out of tolerance.

However, many other unbranded tapes are bad enough to spoil the recording. Such tapes may have the following faults:

1. Defective slitting (too wide, skewed, rough edges) may cause dropouts, poor edge channel uniformity, and failure to guide properly.

2. Defective or poor binder system, causing oxide buildup on the heads and flaking off. This may cause very inconsistent recording quality, sometimes total loss of signal.

3. Highly abrasive tapes which may produce head wear several times normal do exist. Conscientious manufacturers control the abrasive properties of tape keeping it low in all products, so even their rejects are likely to produce low head wear. However, the buyer of unbranded tape doesn't know whose tape he is buying.

This really sums up the difficulty with white-box tapes; *i.e.*, the user cannot depend on what is in the box. With the exception of head wear, the other shortcomings of white-box tapes should not disqualify them altogether. There are always some less important recording needs which do not require the best. If possible, the tape should be tried prior to the actual session, by recording several sections of the reel and listening for the results.

In conclusion, the reader has seen that there are a good many different types of recording tape with a wide variety of characteristics. The informed user, however, should have little difficulty in making the best selection for his own particular needs. ▲

Fig. 10. Response of special triple-play tape in Philips-type cassette is seen to be quite good out to about 10 kHz.

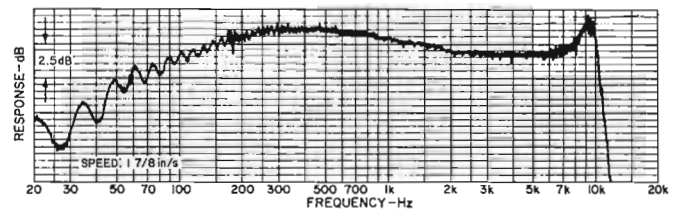

# Why not sell the best

## ZENITH TUBES built to the quality standards of Zenith original parts

### "Royal Crest" Circuit Tubes

More than 875 tubes—a full line with the same quality as original Zenith equipment. Get Zenith tubes for greater dependability and finer performance.

Order all genuine Zenith replacement parts and accessories from your Zenith distributor.



### TV Picture Tubes

For color TV, B&W TV or special purposes. A complete Zenith line of more than 200 tubes built for greater reliability, longer life.

Zenith B&W replacement picture tubes are made only from new parts and materials except for the glass envelope in some tubes which, prior to reuse, is inspected and tested to the same high standard as a new envelope. Some color picture tubes contain used material which, prior to reuse, is carefully inspected to meet Zenith's high quality standards.

**ZENITH®**  
The quality goes in before the name goes on



# BOOK REVIEWS

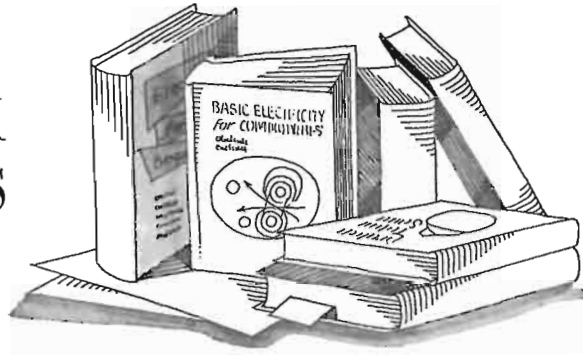

**"MOSFET IN CIRCUIT DESIGN"** by Robert H. Crawford. Published by *McGraw-Hill Book Company*, New York. 132 pages. Price \$10.00.

This is another volume in the *Texas Instruments' Electronic Series* covering the latest advances in electronic design and application. Written by a Senior Engineer at *TI*, the book represents a compilation of practical and useful information of interest to circuit designers.

The author has provided all the requisite background material for a complete understanding of MOSFET circuit design. Included are a detailed description of an actual MOSFET complex integrated circuit; threshold variation with back gate bias; gate voltage dependency of channel mobility, including equations for mobility; and transient response of MOSFET load resistors. Since the author has been directly involved in the design, analysis, and fabrication of MOSFET devices and circuits, the book speaks with authority. Since the volume is addressed to design engineers, there is has been no attempt to simplify or eliminate mathematical treatment. Those working in the field and those with the necessary background in transistor technology will find this volume invaluable.

\* \* \*

**"THE SLIDE RULE"** by Alfred L. Slater. Published by *Holt, Rinehart and Winston, Inc.*, New York. 288 pages. Price \$5.50. Soft cover.

This is designed as a classroom workbook for students enrolled in any of the engineering disciplines. The text abounds in illustrative examples together with a number of practice problems. Since answers are provided for all of the exercises, persons studying on their own could use the manual as well as matriculated students.

The first twelve chapters cover the C, D, CI, CF, DF, CIF, A,B, and K scales while the balance (8 chapters) deals with trigonometric scales (S, ST, T), the log scale (L), and the log-log scales (LL). There is a chapter covering review exercises at the end of each of the two main sections. There are six appendices covering specialized applications of the slide rule and a section providing answers to the various exercises.

The spiral binding permits the book to lie flat on the lab bench or desk and the large clear print with the answers printed in boldface type make the book a pleasure to use.

\* \* \*

**"TRANSISTOR BASICS: A SHORT COURSE"** By George C. Stanley, Jr. Published by *Hayden Book Company, Inc.*, New York. 96 pages. Price \$2.75. Soft cover.

Although the author is an engineer at *Hewlett-Packard Company*, he has a soft spot in his heart for the hundreds of bewildered souls who are finding it harder and harder to acquire an understanding of transistor *basics* from the flood of engineering texts pouring off the printing presses.

Written for technicians, students, and others interested in working with transistorized equipment, the style is informal and non-intimidating. In the introductory chapter the author carefully explains transistor terminology before going on to discussions of transistors and diodes; leakage current, stabilization, and biasing; amplifier action; the *h*-parameter equivalent circuit; simplified circuit analysis; feedback; other semiconductor diodes; special devices; handling transistors; and troubleshooting techniques. Schematics, line drawings, and graphs are used extensively in order to keep mathematics to a minimum.

\* \* \*

**"THE ELECTRONIC INVASION"** by Robert M. Brown. Published by *John F. Rider Publisher, Inc.*, New York. 175 pages. Price \$3.95. Soft cover.

This is a "how to" book with names named and circuits diagrammed (complete with parts lists). If anyone has been worrying about "Big Brother" up to this time, he can really stay awake nights now, since virtually anybody can "get into the act". Sources of supply for "electronic eavesdroppers" of varying degrees of sophistication are listed with addresses, catalogue numbers, and prices. The book is basically an amplification of the author's article "Electronic Eavesdropping", which appeared in the April 1967 issue of *ELECTRONICS WORLD* magazine.

Included in Mr. Brown's thorough investigation of his subject are telephone bugging devices, eavesdropping micro-

phones and their amplifiers, FM wireless mikes and room bugs, bumper beepers, recording spies, and the spy receiver. The author plays fair with his reader by discussing the art of bug detection, speech scramblers to foil bug-gers, and bugging and debugging equipment of various types.

If this book starts you scanning the real estate ads for properties in the Canadian wilds, nobody will blame you. One thing any reader "agin" this invasion of his privacy can do is needle his Senator and Representative to insure passage of the pending legislation barring eavesdropping.

\* \* \*

**"TRANSISTORS: PRINCIPLES AND APPLICATIONS"** by R.G. Hibberd. Published by *Hart Publishing Company, Inc.*, 510 Sixth Ave., New York, N.Y. 10011. 297 pages. Price \$6.95.

The author, who is manager of the Research and Development Department of *Texas Instruments Limited* (England), was asked to prepare a basic text for students and technicians which would not rely too heavily on mathematics or prior experience with semiconductors. He has done an excellent job.

After a brief introductory chapter tracing the history of transistors, the author covers basic principles, transistor characteristics, transistor technology, associated semiconductor devices, transistor equivalent circuits and parameters, d.c. operating conditions, low-level low-frequency amplifiers, high-power audio amplifiers, high-frequency amplifiers, transistor oscillators, transistor radio receivers, the transistor as a switch, d.c. amplifiers, power supplies, the use and handling of transistors, solid circuit techniques (integrated circuits), and recent developments.

Some of the terminology is British as is the spelling. Many of the circuits used by the author to illustrate various transistor applications are of British derivation and, as such, use "non-standard" components which the American builder might have trouble finding (80 and 30 ohm speakers, for example). If the book is to be used to learn the important applications and performance parameters of transistors and not as a "build-it-yourself" handbook, it fills the bill admirably.

\* \* \*

**"SERVICING TV RECEIVER CIRCUITS"** by the editors of "Electronic Technician." Published by *TAB Books*, Thurmont, Md. 219 pages. Price \$6.95.

This is a compilation of selected articles from "Electronic Technician" covering troubleshooting of color and black-and-white receivers. Special emphasis is placed on sets in the "tough-dog" category and the book contains a number of useful hints for locating and correcting such receiver faults.



# SOLID-STATE FLASHERS FOR LIGHT DISPLAYS

By A. A. ADEM / Semiconductor Products Dept., General Electric Co.\*

*Basic semiconductor circuits for incandescent light displays, warning and traffic lights, and illuminated advertising signs.*

**T**HIS article describes some basic semiconductor circuits for incandescent light displays, warning and traffic lights, and illuminated advertising signs. The SCR and the Triac are ideal for this type of application to switch heavy loads on and off. These solid-state switches have no contacts to bounce, stick, or wear out; they are economical, explosion-proof, and reliable.

Flashers are widely used in traffic control, mostly as hazard warning signals where one or two lights alternately flash on and off at a predetermined rate.

## A.C. Flasher

Most flashers available today have a motor-driven cam, actuating heavy silver contacts. The arc generated the instant the contacts open and close, the high in-rush current obtained by switching a tungsten lamp, and the mechanical wear of the contacts limit the operating life of this system.

The circuit of Fig. 1 illustrates a basic a.c. flasher with no moving parts. It is basically a free-running unijunction oscillator triggering a transistor flip-flop which, in turn, alternately fires two Triacs capable of handling 1-kW load each. If a single lamp output with only "on-off" performance rather than two alternately flashing lamps is desired, Triac 2 can be omitted, but the connection noted in Fig. 1 should be made.

The operation of the circuit is as follows: transformer T1, diodes D1 through D4, resistor R1, and capacitor C1 provide the d.c. supply to the free-running unijunction oscillator Q1 and to the transistor flip-flop Q2, Q3. Because of the ripple on base 2 of unijunction Q1, C2 can reach the peak-point voltage of Q1 only at the beginning of the half cycles, thus firing Q1 early in the half cycle. The synchronization of the unijunction transistor minimizes the effect of radio-frequency interference. The frequency of oscillation of Q1 is

determined by the actual setting of control R2.

Collector-gate resistors R5 and R6 form a divider network with R1, supplying about 6 volts d.c. to the flip-flop. Suppose initially Q2 is "on" and Q3 is "off." In this case, the collector of Q2 will be at a negative potential with respect to the gate and lower terminal (1) of Triac 1 while the collector of Q3 will be at the same potential as the gate and terminal 1 of Triac 2. The negative potential at the gate will cause electron current to flow out of the negative side of the d.c. supply, through transistor Q2 (from emitter to collector), R5, through the gate and terminal 1 of Triac 1 to the positive side of the d.c. supply. Current flow into the gate of Triac 1 will cause it to conduct, energizing load #1. Since the gate and terminal 1 of Triac 2 do not see a different potential, there will be no current flow to or from the gate and therefore Triac 2 will remain off.

The timing capacitor, C2, charges through R2 and R3 and when the voltage across it reaches the peak-point voltage of the unijunction transistor, Q1, it discharges, producing a negative-going pulse across resistor R4. A negative-going pulse at the junction of C3 and C4 will change the state of the flip-flop, turning Q2 "off" and Q3 "on," causing Triac 1 to stop conducting and Triac 2 to conduct. In this manner, the Triacs will turn on and off alternately every time the unijunction fires.

It should be noted that the on-time is equal to the off-time with the connection of the unijunction as shown in Fig. 1. This does not permit the variation of one of the timings without changing the other one as well. To obtain independent timing for the "on" and "off" functions, diode gating similar to the arrangement in Fig. 2 is necessary.

Fig. 1. An a.c. flasher circuit using unijunction oscillator triggering a flip-flop which, in turn, fires two Triacs.

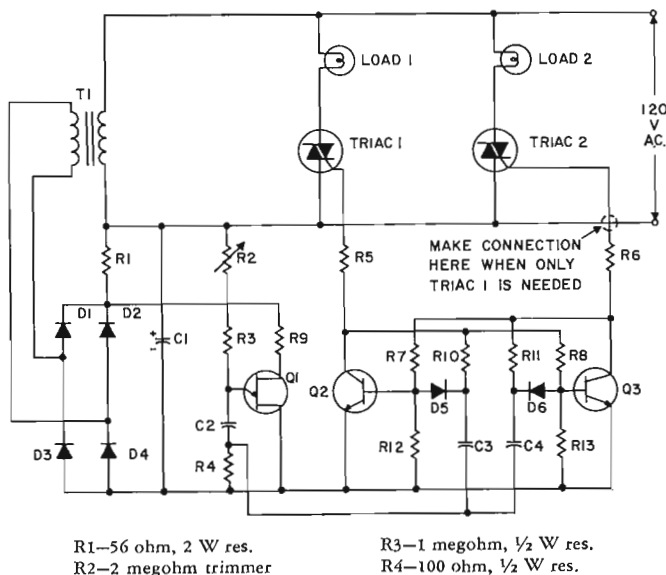

- R5, R6—33 ohm, 1/2 W res.
- R7, R8, R9—680 ohm, 1/2 W res.
- R10, R11, R12, R13—10,000 ohm, 1/2 W res.
- C1—500 μF, 25 V elec. capacitor
- C2—2 μF, 200 V capacitor
- C3, C4—0.05 μF, 200 V capacitor
- D1, D2, D3, D4—A13F diode (G-E)
- D5, D6—1N4009 diode (G-E)
- T1—120:12.6 V stepdown trans.
- Triac 1, Triac 2—G-E SC45B for 1 kW load; G-E SC40B for 600 W load
- Q1—2N2646 unijunction transistor (G-E)
- Q2, Q3—2N3416 transistor (G-E)

R1—56 ohm, 2 W res.  
R2—2 megohm trimmer

R3—1 megohm, 1/2 W res.  
R4—100 ohm, 1/2 W res.

\*Now employed by Fairchild Semiconductor in Mountain View, Calif.



A SELECTION OF  
**ANNUALS**  
STILL AVAILABLE  
FROM THE WORLD'S LARGEST PUBLISHER  
OF SPECIAL INTEREST MAGAZINES



**SKIING INTERNATIONAL YEARBOOK**  
A luxuriously illustrated compendium of 1966's important events... A timely forecast of the excitement-packed 1967 season—by the editors of Skiing Magazine.  
1967 — \$1.25... #48  
1966 — \$1.25... #26



**FLYING ANNUAL**  
The most valuable aviation yearbook ever compiled... Pilot reports... Aircraft directory... How to buy a used airplane... Navcom directory... Learn to fly section.  
1967 — \$1.50... #44  
1966 — \$1.25... #27  
1965 — \$1.25... #28



**ELECTRONICS INSTALLATION AND SERVICING HANDBOOK**  
The only complete guide for servicemen and hobbyists to every major phase of consumer electronics servicing.  
1967 — \$1.25... #43  
1966 — \$1.25... #32



**ELECTRONIC EXPERIMENTER'S HANDBOOK**  
Many challenging projects for the electronics hobbyist.  
1966—Fall Edition—\$1.25... #39  
1966—Spring Ed.—\$1.25... #36  
1965—Fall Edition—\$1.25... #9  
1965—Spring Ed.—\$1.25... #14



**COMMUNICATIONS HANDBOOK**  
The most complete and up-to-date guide to the exciting world of specialized radio communications.  
1967 — \$1.25... #47  
1966 — \$1.25... #18  
1965 — \$1.00... #19  
1964 — \$1.00... #20



**FLYING TRAVELGUIDE**  
Here's the first really useful guide to flying vacations. Everything you need to know about: lodgings, restaurants, resorts, sightseeing, recreation, sports activities, airport facilities, children's fun, price information, special information for the gals—and much more.  
1967 — \$1.25... #46  
1966 — \$1.25... #34

Ziff-Davis Service Division, Dept. W  
595 Broadway, N.Y., N.Y. 10012.

I am enclosing \$\_\_\_\_\_ for the annuals circled below. My remittance includes an additional 15¢ per copy for shipping and handling (50¢ for orders outside U.S.A.). I understand quantities are limited and orders will be filled on a first come—first served basis.

- 9 14 18 19 20 26 27 28 32  
34 36 39 43 44 46 47 48

name \_\_\_\_\_ please print  
address \_\_\_\_\_  
city \_\_\_\_\_  
state \_\_\_\_\_ zip code \_\_\_\_\_

■ PAYMENT MUST BE ENCLOSED WITH ORDER ■

Such a.c. flashers are quite popular when it comes to handling hundreds of watts of power. At lower power levels, or in some applications where there is no a.c. power available, such as automotive or portable flashers, d.c. flashers come in handy.

**D.C. Flashers**

These d.c. flashers are nothing more than SCR flip-flops. Fig. 2 shows such a circuit with variable "on-off" adjustments. The arrangement of diodes D1 through D4 makes it possible to adjust both "on" and "off" times of the load independently. The circuit is a capacitor-commutated SCR flip-flop. The SCR's conduct alternately and are triggered by the pulses out of base 1 of unijunction Q1.

In this type of circuit it is important that at the start, when power is first applied to the circuit, some means be provided to ensure the triggering of only one SCR. The network of R9, C3, and D5 takes care of this situation. When power is applied, both SCR's are off. Because of the positive potential on the anode of SCR1, R9 will apply the same potential to the cathode of D5, thus reverse-biasing it. When a pulse appears at base 1 of Q1, only the gate of SCR1 will receive this pulse and only SCR1 will be turned on. Capacitor C4 will now charge through the load with positive on the side connected to the anode of SCR2 and nearly ground potential at the anode of SCR1. With SCR1 on, the bias on D5 is removed, and the junctions of D1 and D2 are clamped to nearly 1 volt because D2 is now forward-biased. Capacitor C1 now starts charging through R1, R3, and D3. At the end of the time-delay, which is adjusted by setting R1, the unijunction will produce another pulse, turning SCR2 on. This corresponds to connecting

C4 across SCR1 so that it is momentarily reverse-biased. The momentary reversal of anode potential turns SCR1 off. With SCR2 on, diode D4 is forward-biased and therefore C1 starts charging through R2, R4, and D1. With this arrangement, the off time (SCR2 "off") is determined by the setting of R1 and the on time is determined by the setting of R2.

SCR2 should be selected so that the maximum load current is within its rating. Since SCR1 is used for commutating SCR2, it can have a lower rating than SCR2. It will be noted that the more current through the load, the larger the value of C4 would have to be. The minimum value of C4 can be determined from the formula  $C4 \cong (1.5 t_{off} I) / E$  where C4 is in  $\mu F$ ,  $t_{off}$  is the turn-off time of the SCR (in  $\mu sec$ ), I is the maximum load current (including possible overloads) in amperes at time of commutation, and E is the minimum d.c. supply voltage.

If the anode of SCR1 had a lamp in its circuit as a load, rather than R10, the circuit as shown would not function properly because when SCR1 is on, the trigger pulse is coupled to both gates and SCR1 would not have sufficient time to turn off due to the short time-constant involved. With the component values shown in Fig. 2, however, triggering SCR1 and SCR2 at the same time is not objectionable because the time-constant R10-C4 is much longer than the trigger pulse width, so that SCR1 remains reverse-biased long enough after the end of the trigger pulse to assure commutation of SCR1. To be able to drive equal loads in the anodes of the SCR's, the SCR1 gate in Fig. 2 would need a bias similar to SCR2 gate bias. If this is the case, some additional starting means would have to be incorporated in the circuit. ▲

Fig. 2. The d.c. flasher using SCR flip-flops along with variable time adjustments.

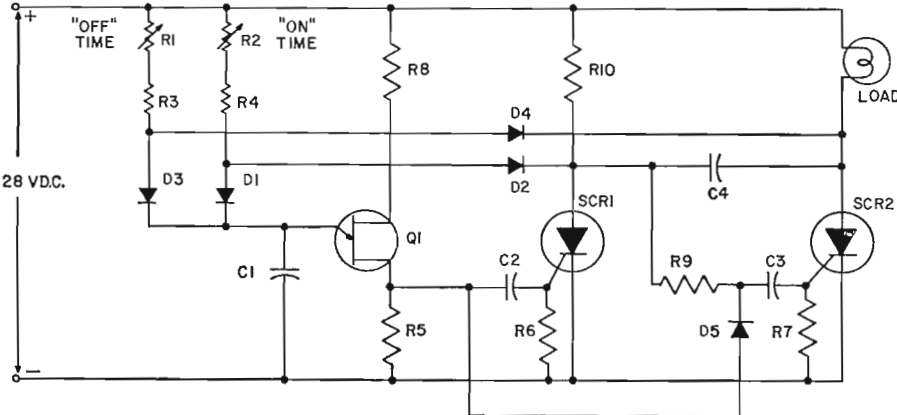

- R1, R2—500,000 ohm linear pot
- R3, R4—750,000 ohm, 1/2 W res.
- R5—100 ohm, 1/2 W res.
- R6, R7—1000 ohm, 1/2 W res.
- R8—270 ohm, 1/2 W res.
- R9—4700 ohm, 1/2 W res.
- R10—250 ohm, 5 W res.
- C1—0.47  $\mu F$ , 50 V capacitor

- C2, C3—0.22  $\mu F$ , 50 V capacitor
- C4—4  $\mu F$ , 50 V non-polarized capacitor
- SCR1, SCR2—Silicon controlled rectifier (G-E C106F)
- D1, D2, D3, D4, D5—A13F diode (G-E)
- Load—1.4 A lamp (G-E 50C)
- Q1—2N2646 unijunction transistor (G-E)

*Bring your slides and movies to Life...*

**( and your audience, too! )**

WITH VOLUME II

# SOUND FOR A PICTURE EVENING

This superb 12-inch, 33 1/3 rpm record brings you 30 selections of sparkling, mood-setting off-beat music and hard-to-find, sound effects. For use "as is" by playing the appropriate tracks as your slide or movie show proceeds or for editing your selections and recording them on tape, "Sound For A Picture Evening" adds another dimension to your photography—high fidelity sound.

PHOTOGRAPHY.

VOLUME II

## SOUND FOR A PICTURE EVENING



30 bands of unusual background music & sound effects specially chosen for slide shows & movies

*19 Bands of mood and special-situation music...  
11 Bands of unusual, hard-to-find sound effects...*

### MADE WITH PHOTOGRAPHERS IN MIND

Photographers are travelers . . . are parents . . . are sportsmen . . . are restless experimenters with the unusual. And so the editors of POPULAR PHOTOGRAPHY have produced this second volume of unusual music and sound effects expressly to match the activities and moods in the most popular types of pictures shown in slide and home movie shows. These are melodies and sounds selected from the vast resources of the Capitol Record Hollywood Library to fit the special needs of photographers. The 30 bands of "Sound For A Picture Evening, Vol. II" supplement but do not duplicate any of those in the first edition of this popular record.

### A POPULAR PHOTOGRAPHY EXCLUSIVE

The "Sound For A Picture Evening, Vol. II" album has been produced by the editors of POPULAR PHOTOGRAPHY exclusively for our readers and is prepared by the Custom Services Division of Capitol Records. This outstanding album, which cannot be purchased in any store, is available by mail only to the readers of Popular Photography and other Ziff-Davis magazines.

### YOU GET 30 SPECIAL MUSIC AND SOUND TRACKS

There are 19 bands of mood and special-situation music . . . 11 bands of unusual, hard-to-find sound effects.

MOODS: Majestic, Backyard Nature, Experimental, Mysterious, Music of the Spheres • NATIONAL PORTRAITS: Vive la France, German Village Band, Soul of Spain, American West, English Countryside, Buon Giorno, Italia •

SOUND EFFECTS: Bass Drum, Bassoonery, Cathedral Bells, Galloping Horses, Zoo Noises, Children at Play, Cocktail Party, Birds on a Spring Morning, Outboard Motor, Oars in Water, Skis on Snow, Trumpet Fanfare, Solo Violin • SPECIAL PURPOSE MUSIC: Music From Silent Movies, Music for Slow-Motion Movies, Music for Speeded-Up Motion, Music for Stop-Motion Movies, Underwater Music, Music for Old-Time Footage.

For photographers with wanderlust, you'll find the "National Portraits" to be authentic melodies to go with your vacation pictures of England, France, Germany, Italy, Spain and the American West.

There are also those special bands to accompany the kind of pictures sportsmen take: The sound of galloping horses, of boat motors, of skis on snow, of oars in the water. You'll even find other-worldly mood-music chosen especially to go with underwater pictures.

Experimental photographers will find the electronic music ideal accompaniment for abstract pictures. The music for stop-motion, slow-motion and speeded-up-motion pictures is fanciful and imaginative in helping to present the unusual scenes being portrayed on your screen. And there is even mood music to convey the visual grandeur of ancient museum relics and photographs of the stars and planets.

To these add many other tracks of carefully selected music and sounds—and you have "Sound For A Picture Evening, Volume II."

COMPLETE WITH INSTRUCTIONS AND BAND POINTER

# FREE!

A comprehensive instruction booklet comes with your record, showing you how to make a successful sound-and-music tape track for your slide or movie show, or to use the record alone as background, even if you're a rank beginner. An ingenious band pointer which fits on top of your record instantly locates any band you want. No guessing, no wasted motion, no false starts.

This 12" long playing vinyl album consisting of selections from the music masters of the Capitol Record Hollywood Library is available to you for

only \$ **3.98** POSTPAID!

It's a must for every slide and film show impresario and an album you will enjoy for many years to come.

### PLACE YOUR ORDER NOW

"Sound For A Picture Evening, Volume II"  
P. O. Box 3118  
Church Street Station, New York, N.Y. 10008

Please send \_\_\_\_\_ "Sound For A Picture Evening, Volume II" albums at \$3.98 each, postpaid.

My check (or money order) for \$\_\_\_\_\_ is enclosed.

(Outside U.S.A. please send \$6.00 per record ordered.)  
N. Y. State residents please add local sales tax.

Name \_\_\_\_\_

Address \_\_\_\_\_ EW-87

City \_\_\_\_\_

State \_\_\_\_\_ Zip Code \_\_\_\_\_

**PAYMENT MUST BE ENCLOSED WITH ORDER**

"SOUND FOR A PICTURE EVENING, VOLUME I" still available  
I missed this first release containing 17 specific mood music backgrounds and 8 tracks for special sound effects. Please send \_\_\_\_\_ "Sound For A Picture Evening, Volume I" albums at \$3.98 each, postpaid. (Outside U.S.A. send \$6.00 per record ordered.)



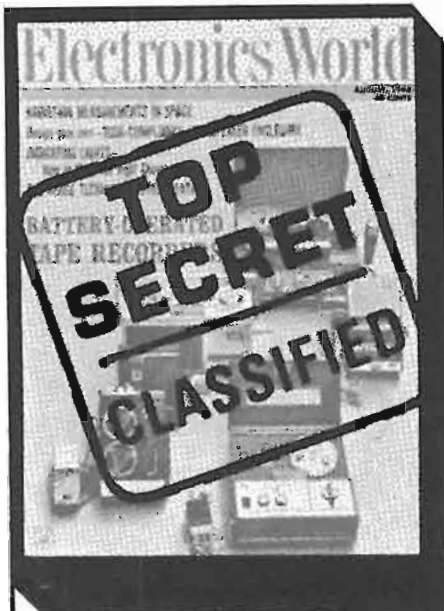

**...not by  
a long shot  
it isn't !!**

There's certainly nothing top secret about the classified pages in Electronics World Magazine. They're wide open to the searching eyes of every buyer who's in the market for the product or service that he knows can be found in Electronics World's Electronics Market Place.

The more than 191,000 buyers of Electronics World, largest readership of any magazine for electronics professionals in the world, are your guarantee of knowing that your ad is being read by people who are constantly looking for and buying electronics products. It is these people to whom you **MUST** direct YOUR advertising as do the many key advertisers appearing in this issue and in each issue throughout the year.

No doubt about it—there's a vast market of buyers searching the classified advertising pages of Electronics World and it's important that your ad be exposed to this prime buying audience. Prove to yourself that the leading magazine for electronics professionals **MUST ALSO** be the leader in sales responses to the many classified ads presently enhancing its pages—it makes a great deal of sense—give it a try.

There's complete rate information for your convenience in the classified section of this issue. Or, if you'd like a little personal service, it's right up our alley. Just write to

HAL CYMES  
Classified Advertising Manager  
ZIFF-DAVIS PUBLISHING COMPANY  
One Park Avenue  
New York, New York 10016

**EW Lab Tested**  
(Continued from page 16)

amplifier to have a high input impedance of 250,000 ohms, and the low-impedance emitter-follower is ideal for supplying signals to a tape recorder without loss of high frequencies due to cable capacitance. RIAA phono and NAB tape equalizations are provided by negative-feedback networks around the preamplifier section.

The driver amplifier section contains the tone control, loudness compensation, volume and balance controls, filters, as well as an amplifier, pre-driver, and driver stage. The latter is transformer-coupled to the output stage, which uses four power transistors. The output is direct-coupled to the loudspeakers, with no blocking capacitors. A 2-ampere thermal circuit breaker is in series with each speaker line, protecting the output transistors against damage from overdriving or output shorts.

With the tone controls mechanically centered, we measured the frequency response as  $\pm 2.75$  dB from 20 to 20,000 Hz. There was a gentle downward slope below 100 Hz, which amounted to 2 dB at 100 Hz and 4.5 dB at 20 Hz. The tone controls had excellent characteristics, with moderate amounts of correction affecting only the lowest and highest frequencies. The filters had 6 dB/octave slopes.

RIAA phono equalization was quite good. Above 10,000 Hz it rose slightly, but there are few phono systems which would suffer from a slight boost in the uppermost octave. The NAB tape playback response had the same high-frequency boost as the RIAA response.

In checking the performance characteristics of a KG-895 which had been constructed from a kit, it soon became apparent that all the quoted specifications listed by the manufacturer were obtained with a line voltage of 125 volts and with only one channel working at a time. This practice is still being followed by some manufacturers, but it is hoped that eventually all companies will quote specifications at the standard line voltage of 120 volts with both channels operating simultaneously. There is still some disagreement as to

whether or not both channels should be driven by in-phase signals. This is the most stringent way of making a power measurement and is the method followed in our lab.

The amplifier, measured at the clipping level of the output waveform with only one channel driven, delivered 48 watts into 8 ohms, 49 watts into 4 ohms, and 27.5 watts into 16 ohms.

With both channels operating simultaneously and driven in-phase at the same frequency, the KG-895 delivered 40 watts per channel into 8 ohms at a distortion of somewhat under 2% from 250 to 5000 Hz. From 100 to 20,000 Hz, the distortion was slightly under 3%. At lower frequencies it rose sharply. At reduced power levels, distortion dropped to negligible levels, being less than 0.5% from 20 to 20,000 Hz at 20 watts (-3 dB) and about 0.4% or less over this range at 4 watts (-10 dB).

At 1000 Hz, the distortion measured 0.25% or less from 0.1 to 22 watts, rising to 1% at 35 watts. The IM distortion was about 0.5% at 0.1 watt, 1% at 8 watts, and near 2% at 20 watts.

The hum was unmeasurably low and was completely inaudible on all inputs at full volume. There was some hiss on the low-level inputs at full volume, and a very slight amount on the high-level inputs. However, the gain of the amplifier is very high (only 1 millivolt on low-level, or 120 millivolts on high-level inputs for 10 watts output), and when the level controls are set for normal operating conditions, the hum and hiss are 66 dB below 10 watts on phono and 73 dB below 10 watts on high-level inputs—a completely inaudible level.

Even though the amplifier did not quite measure up to quoted specifications when tested in accordance with our stringent methods, we found it to be very easy to live with both from the standpoint of operating ease and sound. Considering its cost, the overall performance is outstanding and there is little doubt that this unit compares favorably with many others which sell at a higher price.

The "Knight-Kit" KG-895 amplifier sells in kit form for \$149.95. A handsome oiled-walnut wooden cabinet is available for \$19.95. ▲

**Empire 888 Phono Cartridge**

For copy of manufacturer's brochure, circle No. 30 on Reader Service Card.

**T**he Empire 888 is more than just a stereo phono cartridge—it is a complete family of cartridges with perhaps the widest choice of operating parameters available in a single basic phono product. The 888 Series shares a common body which contains the coils, pole pieces, and magnets, enclosed in a magnetic shield which virtually elimi-

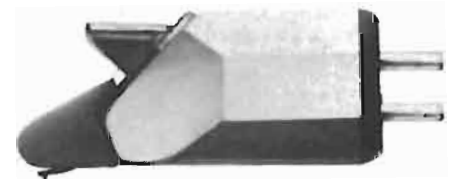

nates the possibility of induced magnetic hum in any normal installation.

The plug-in stylus assembly contains a small cylindrical tube which encloses a conical piece of magnetic material mounted on the free end of the stylus cantilever. As the stylus follows the groove modulation, the magnetic cone at the other end of the lever arm is moved relative to the four pole pieces within the cartridge body. It acts as a gate for the fixed magnetic field within the cartridge, channeling the flux to the four coils in which are induced a voltage proportional to the stylus velocity in left and right channels.

A total of five styli are available for the cartridge, differing in mass, compliance, stylus dimensions, frequency response, and tracking force requirements. For use in older record changers requiring relatively high tracking forces there is the basic Model 888, with a 0.7-mil stylus capable of operating at forces up to 6 grams. The advantages of an elliptical stylus are offered with relatively high tracking force in the 888E, which has a  $0.4 \times 0.9$  mil stylus capable of playing at up to 5 grams.

For better grade players and tonearms, there is the 888P with a 0.6-mil stylus rated for a maximum tracking force of 4 grams. Still higher compliance and a maximum force of 3 grams are offered in the 888PE with a  $0.2 \times 0.9$  mil elliptical stylus. The newest of the series, tested for this report, is the 888SE which has a  $0.3 \times 0.7$  mil elliptical stylus operating at less than 3 grams. All of these cartridges are capable of operating below their maximum rated tracking force where the tonearm design permits.

Using the "HiFi Stereo Review" 211 test record, we found that the *Empire 888SE* tracked the low and high frequency tracking test bands at 1.5 grams. The frequency response and channel separation were measured with the *CBS STR100* sweep-frequency record and a *General Radio* graphic level recorder from 40 to 20,000 Hz. The frequency response was very smooth and free from irregularities with a slight downward slope amounting to a  $\pm 1.5$  dB variation from 40 to about 13,000 Hz. The stylus resonance occurred at about 15,000 Hz, producing a

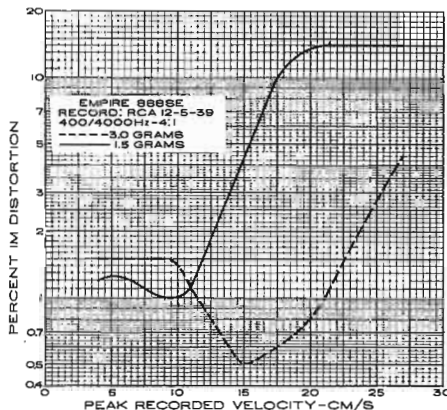

peak of about 5 dB and returning to the below-10,000-Hz level at 20,000 Hz. Channel separation was about 27 dB at middle frequencies, 20 dB at 10,000 Hz, and 10 dB or better above 15,000 Hz.

The intermodulation distortion measured with the *RCA 12-5-39* test record was about 1% at normal recorded velocities, reaching 2% at 13 cm/s. Increasing the tracking force to the rated maximum of 3 grams allowed the tracking of 24 cm/s recorded velocities with 2% distortion. For playing most heavily recorded stereo discs, we would recommend a force of 2 to 2½ grams.

The square-wave response, with the 1000-Hz bands of the *CBS STR110* record, showed a single cycle of ringing at the stylus resonance frequency with a slight convexity indicating the relative increase of output below 1000 Hz, compared to the higher frequency output. The output of the 888SE was about 3.1 millivolts at 3.54 cm/s velocity.

The sound of the *Empire 888SE* was full and solid with no audible emphasis of any part of the spectrum. The peak which we measured at 15,000 Hz was evidently too high in frequency to be audible since the output of the cartridge was noteworthy for its silent background and freedom from hiss. The hiss level, in fact, was considerably less than that from several other cartridges which did not exhibit the peaked response in the measurements.

The *Empire 888SE* cartridge sells for \$44.95. ▲

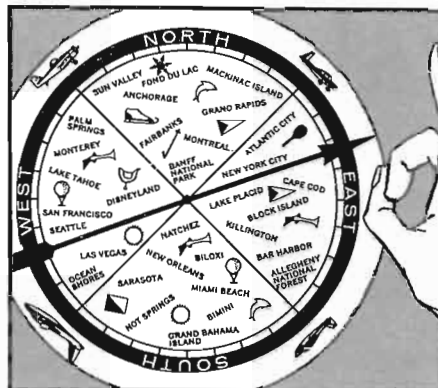
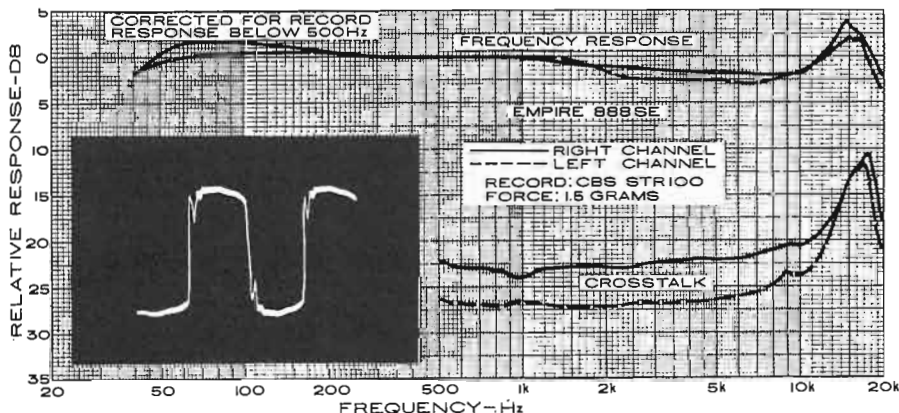

## Pick a trip, any trip.

North, East, South or West.  
Any place at all.

... Whether you're planning a flying vacation right here in the States, Canada, Mexico, Alaska, the Bahamas

... Or plotting a business trip in your company plane, with an eye out for that special resort where you can unwind after hours—

Wherever your flying travels take you this year, the all-new 1967 FLYING TRAVELGUIDE will show you the way.

It's the only complete, useful fly-in directory assembled exclusively for pilots. Designed specifically to lead you to the facilities you need... the accommodations you want... and the activities you enjoy most. Forget about poring through land-oriented travel brochures, and gambling on what you'll find when you get there. The FLYING TRAVELGUIDE is guaranteed to get you off the ground and headed toward the greatest flying pleasure ever.

Every region is geographically indexed and cross-referenced so you can easily pick out—and chart your course to—the places you'll like best. You'll find 164 pages of detailed, illustrated, pilot-to-pilot information for each area... covering:

- airport facilities
- resort and area listings
- lodgings and prices
- sightseeing
- regional flying tips
- surface transportation
- state-by-state calendar of important events
- children's attractions
- restaurant recommendations
- tips for the gals
- convention sites
- including special attention to skiing, hunting, golf, fishing, tennis, riding, scuba, boating and skating facilities!
- Plus a complete run-down on Montreal's fabulous Expo 67!

So whether you own a plane, rent one, or pilot your company's craft, you owe it to yourself and your passengers to land a copy of the 1967 FLYING TRAVELGUIDE.

only **\$1.25**

The 1967 FLYING TRAVELGUIDE is also available in a handsome deluxe edition. Rugged Leatherflex cover provides permanent protection yet is softly textured and gold-embossed for the look of elegance. A collector's item—a superb addition to your aviation bookshelf. And it's yours, for just \$3 postpaid, when you check the appropriate box on the order form.

### FILL IN AND MAIL THIS COUPON TODAY!

Ziff-Davis Service Division/Dept. FT  
595 Broadway/New York, N.Y. 10012

Roger! Send my copy of FLYING's 1967 TRAVELGUIDE right away!

- \$1.25 (plus 15¢ for shipping and handling, 25¢ outside U.S.A.) is enclosed. Send me the regular edition.
- \$3.00 enclosed. Send me the Deluxe Leatherflex-Bound edition, postpaid. (\$3.75 for orders outside the U.S.A.) Allow two extra weeks for delivery.

NAME \_\_\_\_\_  
ADDRESS \_\_\_\_\_  
CITY \_\_\_\_\_  
STATE \_\_\_\_\_ ZIP CODE \_\_\_\_\_  
PAYMENT MUST BE ENCLOSED WITH ORDER.



# NEW PRODUCTS & LITERATURE

Additional information on the items covered in this section is available from the manufacturers. Each item is identified by a code number. To obtain further details, fill in coupon on the Reader Service Card.

COMPONENTS • TOOLS • TEST EQUIPMENT • HI-FI • AUDIO • CB • HAM • COMMUNICATIONS

## FLUIDIC COMPONENTS

Simplicity and speed of setup are features claimed for the new "Flowboard" just being introduced. The Flowboard is one item in a new line of fluidic components. The standard unit has



22 fluidic amplifiers which can be easily and quickly programmed to meet most control needs. Integrated Flowboards, without external intra-connections, can be provided on a custom basis.

The companion items in the new line are connectors, a filter, an air pulse generator without moving parts, and a self-contained control unit, the F-132, which contains 132 fluidic amplifiers, filter, regulator, and a pressure indicator. In the near future the company expects to offer input sensors and output transducers (converters) in order to provide complete systems compatibility. Pitney-Bowes

Circle No. 126 on Reader Service Card

## NEW ANTENNA LINE

New electronic and construction design are features of the new "Super Colortron" antenna line which has been recently introduced.

Among the electronic features are instant-loading solid-state cartridge preamps and terminal cartridges that slip into a totally enclosed weatherproof cartridge housing at the point of signal interception. Both 300- and 75-ohm v.h.f., u.h.f., and 82-channel cartridge preamps are available. Three other cartridges are also available. A color spectrum filter cartridge allows only pure TV signals to come through, shutting out all other electromagnetic frequencies. Either 300-ohm or 75-ohm terminal cartridges give complete weather protection where a preamp or color spectrum filter is not used.

The new "Super-Colortron" line consists of five 82-channel antennas, four v.h.f. models, and three u.h.f. models. Complete details on the entire line will be forwarded on request. Winegard

Circle No. 1 on Reader Service Card

## INDICATOR LIGHTS

A new series of indicator lights designed for mounting in an  $\frac{1}{16}$ " clearance hole is now available. These assemblies accommodate T-2 bulbs with telephone slide bases (PSB type) and have a minimum lamp life of 5000 hours.

There is a choice of five lens styles, seven lens colors, and hot stamped legend markings which permit unusual flexibility in color/legend identification. Dialight

Circle No. 127 on Reader Service Card

## RADIO INTERFERENCE FILTERS

The Series 104 radio interference filters are now available for both single-phase and three-phase power systems, in a broad choice of voltage, current, and insertion loss values.

Designed and manufactured to specifications which meet or exceed requirements of MIL-F-

15733E, the filters are designed for use with single-, dual-, and three-wire power systems. For three- and four-wire systems, the Series 104 also includes three- and four-circuit models.

Standard voltage values include 28 and 100 volts d.c. as well as 400 volts d.c., 125 volts a.c. and 600 volts d.c./250 volts a.c., both in 0-60 Hz or 0-400 Hz frequency ranges. Standard current ratings range from 1 through 10 amps. Elpac

Circle No. 128 on Reader Service Card

## SEMI-AUTOMATIC ROTATOR

The new semi-automatic "Colorotor", Model 9513, incorporates a motor instead of a meter in the control console. This motor, driving the position indicator dial, is synchronized with the exterior drive unit motor to provide more precise aiming and relocation of stations than is possible with manual meter indicators.

Hookup of the new model is simplified through the use of three-conductor wire. Channel Master

Circle No. 2 on Reader Service Card

## CAPACITORS FOR PC BOARDS

A complete product line of miniaturized instrument-grade metallized polycarbonate capacitors encased in durable, moisture-resistant, rectangular black molded cases with radial leads for PC board mounting has just been introduced.

The 3908 series is available in a capacitance

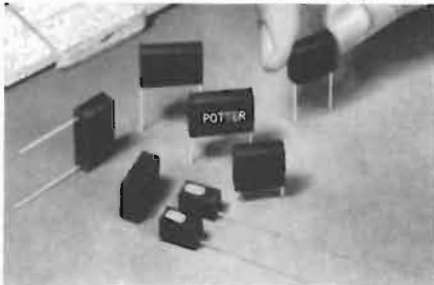

range from 0.001 to 2  $\mu$ F. They are designed for use in ground and airborne computer circuitry, electronic data processing equipment, communications equipment, instrumentation and process control, and other applications where these characteristics are required. Potter

Circle No. 129 on Reader Service Card

## LOW-COST SPARK GAP

A new series of spark gaps that provide protection from transient voltages up to 2500 volts has just been announced.

The new units permit designers to specify other less expensive, lower voltage components in grid and deflection circuitry because they assure the harmless bypass of stray transients in color-TV applications. By using the cross-section of a wire lead as the electrode, and by precisely controlling the gap width, repeated arcing is assured with no appreciable increase in start voltage.

The new Type SG line is available with arc voltages of 1500 to 2500 volts, two standard EIA color-coding bands indicate the first two figures of breakdown voltage. IRC

Circle No. 130 on Reader Service Card

## COMPACT TUBE TESTER

A faster, more versatile tube tester, the TV142 "Mighty Mite V" has just been announced. With an added new magnoval (large 9-pin) and 12-

pin tube sockets, the instrument checks all the latest types—over 3000 foreign and domestic tubes in all.

The tester makes full emission, grid leakage, and shorts tests. Each tube is tested under full rated load to find borderline and "tough dog" types quickly and easily. A high sensitivity of 100 megohms or  $\frac{1}{2}$   $\mu$ A of grid current tracks down the intermittent, leaky, or otherwise hard-to-find tube.

Compact and completely portable, the tester is housed in a rugged vinyl-clad steel case with detachable hinged cover for full protection when not in use. An up-to-date setup booklet is included. Sencore

Circle No. 3 on Reader Service Card

## NUTDRIVER/SCREWDRIVER KIT

A new 14-piece multi-purpose tool kit that takes up little space in a tube caddy and is even light and compact enough to be carried easily in the hip pocket has just been introduced as the Model No. 99PR.

The roll kit contains a master handle, nine interchangeable nutdriver blades with hex openings from  $\frac{3}{16}$ " through  $\frac{1}{2}$ ", #1 and #2 Phillips single-end screwdriver blades, and two single-end blades for slotted screws with tip widths of  $\frac{3}{16}$ " to  $\frac{1}{4}$ ".

The plastic handle is shockproof and break-proof. A patented spring device holds the blades firmly, yet permits easy insertion and removal. Bulletin N367 contains complete specifications on this and other tool kits. Xcelite

Circle No. 4 on Reader Service Card

## ELECTRIC SCRIBER

An inexpensive electric tool which permanently marks metal, glass, stone, ceramic, plastics, hard rubber, wood, etc. is now available. The new unit can be used to mark stock numbers, part numbers, sizes, or names right on the components, tools, and equipment.

The new internal construction reduces "bouncing", giving better control for smoother operation. A new coil provides a stronger stroke and won't stall under normal heavy operation. The tool vibrates at 7200 strokes per minute. An adjusting wheel permits the impact force and length of the stroke to be varied for different materials.

The 13-ounce tool measures  $6\frac{3}{4}$ " x  $1\frac{3}{4}$ " x  $1\frac{3}{8}$ " and is available with either a carbide-tipped point or diamond point. Ideal

Circle No. 5 on Reader Service Card

## VACUUM-TUBE READOUT

A vacuum-tube readout which uses a 10-gun CRT offers an electron projection system that displays characters with clarity and brightness



onto a fluorescent screen. Easily viewed under direct sunlight, the vacuum-tube readout can be used under any ambient light conditions.

Features of the new unit include: powerless control grid switching, extremely low power consumption (approx. 300 mW), small grid-control swing, wide viewing angle, continuous brightness control with simple external circuitry, and no external focusing means required. IEE

Circle No. 131 on Reader Service Card

#### SOLID-STATE MICROWAVE SWITCH

The Model M400 coaxial unit was designed to meet the need for a low-cost broadband switch covering 1 to 18 GHz instantaneously with high isolation of over 40 dB above 8 GHz, low insertion loss of 0.5 to 2.0 dB, and moderately high power handling capability of 2 watts c.w. and 100 watts peak power.

The switch can be used in microwave circuits including pulse modulator and shaper, ampli-



tude modulator, T-R switch, limiter, attenuator, automatic gain control, power leveler, frequency synthesizer, suppressed carrier modulator, and redundant microwave system.

The extra wide range is achieved by functionally integrating oxide passivated silicon p-i-n diodes into a 50-ohm miniature coaxial line and by creating a novel bias circuit that overcomes the frequency limitations of conventional blocking capacitors. Hermetic sealing assures reliable operation under severe environmental conditions. Somerset Radiation Lab

Circle No. 132 on Reader Service Card

#### TEST ADAPTERS FOR COLOR-TV

Two new current test adapters are now available to permit current measurements on any pin position of novar and compactron tubes from the tube side of the chassis without cutting any leads.

The adapters have two spring test tab elements for each pin which break the circuit when a dual-sided probe is inserted in test position. Probes are gripped by the test tabs and need not be held in position. Current is read at the meter connected to the two test leads. The same test adapters and probe also permit voltage and waveform readings on any pin position, merely by connecting the leads jointly to the meter. Vector

Circle No. 6 on Reader Service Card

#### 4-P.D.T. PUSH-BUTTON SWITCH

A new miniature 4-p.d.t. push-button switch which features a one-piece body construction for ultra-miniature space requirements is now available.

It features high current rating and is capable of handling multiple circuits simultaneously. In addition, it features high voltage barriers between terminals and contacts, low loss and high impact case material, and new turret-type terminals to simplify wiring. The switch has waterproof "O" rings and sealed terminals and is designed for use in commercial and military applications.

Rated 6 amps at 117 volts a.c., the new switch is available in two types—either as a momentary push-button or push-to-make and push-to-break. Alcoswitch

Circle No. 133 on Reader Service Card

#### MINIATURE RELAYS

A new relay which is mercury wetted, position insensitive and features low noise, high speed, long life, and a choice of latching or non-latching operation is now being marketed as the Series D "Logcell".

Hermetically sealed in a glass capsule, the new

relay will switch 2 amps up to 6 volts and 50 mA up to 100 volts at speeds under a millisecond. The unit is designed to operate uniformly from  $-38^{\circ}\text{C}$  to  $+100^{\circ}\text{C}$  at rates exceeding 250 cycles per second.

The capsule is potted together with independent drive coils and a shielded magnetic latching circuit to withstand severe environmental conditions. Technical Bulletin #1001, available on request, contains complete details on these relays. Fifth Dimension

Circle No. 134 on Reader Service Card

#### ULTRA-HIGH-"Q" VARACTORS

Development of the ultra-high-"Q" (greater than 1000) large-area Schottky barrier junction has resulted in a new line of square-law voltage-variable capacitors.

Because these devices have the ability to exhibit log slopes which are within measurement error of 0.50 exponent, circuit designers can now expect highly accurate tuning ranges with a minimum of required voltage swing. All varactors in the new line show resistive cut-off frequencies in excess of 250 GHz. Zero-voltage capacitance values can be from 1 pF to 500 pF, breakdown voltage is up to 20 V, and "Q" is from 500 to 2000. Specs sheets are available. Solitron

Circle No. 135 on Reader Service Card

#### SOLID-STATE A.C. RELAY

A solid-state a.c. relay with no contacts to wear out has just been introduced as the Model 1500. The relay switches up to a 10-amp, 200-volt a.c. load with a turn-on time of 0.002 second and a turn-off time of less than 0.003 second. A 10-amp, 400-volt model is also available.

The new relay is especially suited to use in transistor output circuits as it is protected against inductive loads and line transients and operates from a 12-volt d.c., 0.025-amp input. Other features include a toggle switch which provides a choice of normally closed or normally open operation.

Complete specifications on the Model 1500 are included in Bulletin #105 which will be forwarded on request. Electro-Sonic

Circle No. 136 on Reader Service Card

#### VARACTOR & DIODE PACKAGES

An "off-the-shelf" line of standard-size varactor and diode packages is now being offered in various flanges and pedestals, ranging in standard ceramic sizes from 0.080" to 0.210" o.d. The flange design employs two metals, "Kovar" for rigidity and copper for low yield point.

The copper, brazed adjacent to the ceramic component, yields and absorbs the stress due to



the difference in thermal expansion between the ceramic and the rigid Kovar. This new flange makes it impossible for stresses to be transmitted to the ceramic-to-metal joint and the assembly is stronger.

Complete information on these new "super-strength" varactor and diode packages will be forwarded on request. Ceramics International

Circle No. 137 on Reader Service Card

#### VIDEORECORDER COLOR ADAPTER

An adapter that can record and play back video tape in color has recently been introduced for use with the EV-200 Videorecorder or virtually any other helical scan machine.

Among the advantages of the adapter are: excellent separation between luminance and chrominance signals, and the fact that purity and clarity of the color picture is unaffected by instabilities inherent in helical-scan video tape recorders.

All necessary circuitry is contained in a small unit and only minor, in-the-field modifications are needed to add the adapter to existing EV-200 units. Complete specifications are available. Sony Industrial

Circle No. 7 on Reader Service Card

#### MARKING STYLUS

The new Model MW210 marking stylus has been designed with the electronics industry in mind for the hand marking of small parts in production or engineering departments where it



is not practical to set up automatic marking machines.

The tool is only  $\frac{3}{4}$ " in diameter, about 7" long, and has no overhanging bulge. It will operate from standard 117-volt, 60-Hz power lines. It comes equipped with standard steel points but diamond and tantalum carbide points are available as accessories. Electro-Stylus

Circle No. 138 on Reader Service Card

#### PORTABLE TUBE TESTER

A compact, portable tube tester with a number of new features is being marketed as the Model 107-C. The tester incorporates a 6AF6G "eye" tube in a patented "Magic-Eye" circuit which effectively spots momentary shorts missed by normal meter lag. This same indicator is used on grid-emission checks and to indicate filament or heater continuity.

Another feature is the unit's constant voltage transformer which is said to provide superior stability and accuracy by delivering proper filament and test voltages. The meter has been designed with a simple, easy-to-read "good/bad" scale and expanded scale for power tube readings. A replaceable 10-socket plug-in panel prevents obsolescence and permits complete testing of all modern TV, radio, hi-fi, industrial, and foreign tubes.

The tester is housed in a vinyl-covered carrying case measuring 13" x 9" x 7". Operation is from 117 volt a.c. Seco

Circle No. 8 on Reader Service Card

#### SLIDE-RULE FOR ELECTRONICS

An electronics slide-rule, designed specifically for speeding all types of circuit calculations, is now being offered complete with a four-lesson instruction course and leather carrying case.

The slide-rule has a special "H" scale for solving resonant frequency problems and a  $2\pi$  scale for inductive or capacitive reactance problems, or any problem involving the  $2\pi$  factor. These scales supplement nine conventional scales—A, B, S, T, CI, C, D, L, and Ln.

The "flip" side of this all-metal, 10-inch rule features a unique reactance and resonance decimal-point locator, and contains useful formulas for frequency and wavelength, Ohm's Law, and a.c. and d.c. circuits, as well as 18 frequently used conversion factors.

A free illustrated booklet giving complete details on this unit will be forwarded on request. Cleveland Institute

Circle No. 9 on Reader Service Card



## HI-FI — AUDIO PRODUCTS

### ALL-PURPOSE AMPLIFIER LINE

A new series of all-purpose amplifiers which is being offered in 10, 20, 35, and 70 watt versions has just been announced. The models in the 3000 Series are designed to meet virtually any sound requirement.

The Model 3075, for example, is rated at 70 watts r.m.s. (140 watts peak), has a frequency



response of 30 to 20,000 Hz  $\pm$  2 dB, noise level 65 dB below rated output (auxiliary), and 45 dB below output (microphone).

Designed for heavy-duty sound amplification in bowling alleys, stadiums, ballrooms, gyms, and warehouses, the unit measures 5 $\frac{1}{4}$ " high x 5 $\frac{1}{16}$ " long x 10 $\frac{13}{32}$ " deep. It is housed in a silver gray cabinet.

Complete specifications on this and the other three models in the line will be forwarded on request. Rauland-Borg

Circle No. 10 on Reader Service Card

### SOUND-LEVEL CALIBRATOR

The Type 1562-A sound-level calibrator is a compact, self-contained unit for making accurate field calibrations on microphones and other sound-measuring instruments. It generates five USASI-preferred frequencies (125, 250, 500, 1000, and 2000 Hz,  $\pm$  3%) at an accurately known sound-pressure level of 114 dB (re 20  $\mu$ N/m<sup>2</sup>). Level accuracy with the Western Electric 640AA or equivalent microphone is  $\pm$  0.3 dB at 500 Hz and  $\pm$  0.5 dB at other frequencies.

Directly or with the adapters supplied, the 1562-A will calibrate many common types of microphones and associated sound equipment. An electrical output of 1 V is provided for tests on instruments without microphones. General Radio

Circle No. 139 on Reader Service Card

### PORTABLE RADIO-CASSETTE PLAYER

A new AM-FM portable radio with a built-in tape cassette player has just been introduced as the Model L573.

The new unit has a removable front panel for insertion of snap-in cassettes, each of which can provide up to 90 minutes of playing time. Mono and stereo cassettes are completely interchangeable and compatible on the player. There is an automatic push-button cassette ejector.

The portable is powered by five "D" cells and weighs six pounds. It is adaptable to a.c. It has a.f.c. for locked-in tuning on FM, a four-inch speaker, a ferrite antenna for AM, and a telescopic antenna for FM. It also has

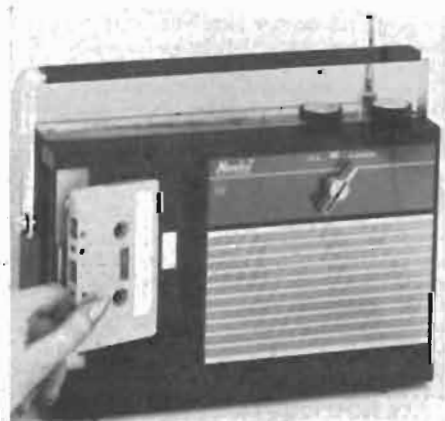

outlets for private earphone listening and for use with a car antenna.

The radio has a vernier slide-rule dial and a convenient carrying handle. It measures 6 $\frac{3}{8}$ " x 10 $\frac{1}{2}$ " x 3" and is housed in a contemporary styled case in black with chrome trim. Norelco

Circle No. 11 on Reader Service Card

### WIRELESS PAGING SYSTEM

A low-cost instant wireless paging system which handles up to ten stations is now available. Each lightweight, 4-ounce pocket signal receiver has its own calling number. At the touch of the corresponding button on the control station, the selected receiver emits a discreet beep signal which only the person being paged can hear.

A unique feature of the system is a storage and charging container for the signal receivers which automatically recharges the units. In addition, the operator can tell at a glance who is in and who is out as each signal receiver has its own numbered slot in the storage rack. TeleTracer

Circle No. 12 on Reader Service Card

### LIGHT ANNUNCIATOR INTERCOMS

A new series of light annunciator intercoms is now being marketed under the Ektacom brand name.

Each selector key has a lamp associated with it and when a staff station places a call, a lamp

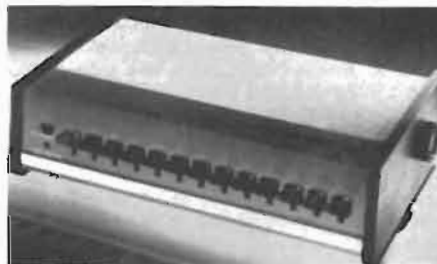

is illuminated behind the name of the calling station. A chime sounds at the same time. The new series also feature lockout circuits which prevent a third party from breaking into existing conversations.

The new system is solid-state and uses solid-state logic and amplifier circuits. A four-inch, 45-ohm loudspeaker, with 1-ounce Alnico V magnet, is used. The circuits are balanced line throughout for minimum noise. Shielded cable is not required in this system. It is a full intermix system.

The entire system is powered by a UL-approved class II solid-state power supply which means that 117-volt a.c. power is required at only one point in the system. Fisher Berkeley

Circle No. 13 on Reader Service Card

### CABINET-MODEL RECORDER

The ReVox G-36W Mark III is housed in a hand-polished satin walnut cabinet designed to fit in with any decor. The recorder will handle up to 10 $\frac{1}{2}$ -inch reels, features three Pabst motors and direct drive, offers a photosensitive cut-off switch, and operates at 3 $\frac{3}{4}$  and 7 $\frac{1}{2}$  ips, two- or four-track option. Elpa Marketing

Circle No. 14 on Reader Service Card

## CB-HAM-COMMUNICATIONS

### CB PORTABLE

A new 14-transistor, two-watt portable transceiver with dual-conversion receiver section has been introduced for licensed CB use.

Designated Model CB-181, the new unit offers communications on two channels over a unit-to-unit range of approximately 5 miles. Military-grade construction and high-level cascade-modulated r.f. output make the CB-181 rugged and reliable, according to the company.

Sensitivity is nominally 1  $\mu$ V for a 10 dB signal-to-noise ratio. Adjacent-channel rejection is greater than 25 dB and, because of the dual-conversion design with i.f. frequencies of 4.225 MHz and 455 kHz, images and spurious signals

are suppressed by more than 20 dB. Ceramic filters are used as emitter bypasses in the second i.f. stage to assist in reducing unwanted signals before detection.

The transceiver measures only 8 $\frac{3}{16}$ " high x 3 $\frac{3}{8}$ " wide x 1 $\frac{13}{16}$ " deep and weighs 1.5 pounds. It has provisions for external antenna, microphone, and either an earphone or separate loudspeaker. Hallicrafters

Circle No. 15 on Reader Service Card

### TWO-WAY CB RADIO FOR BOATMEN

A two-way radio for boatmen and sportsmen provides short-range communications on any two channels in the 27-MHz Citizens Band. The new



TWR-8 uses rechargeable nickel-cadmium batteries which deliver two watts of power for two-way conversations over several miles. Raytheon

Circle No. 16 on Reader Service Card

### 23-CHANNEL CB TRANSCEIVER

A 23-channel, solid-state CB transceiver which comes complete with crystals for all 23 channels is now available as the "Classic".

Features include an illuminated "S" meter and channel selector, p.a. system, auxiliary speaker jack, single-knob tuning, modulation indicator, d.c. cord, and a special "safety circuit" to protect against mismatched antenna, incorrect polarity, and overload.

The transceiver measures 6 $\frac{1}{2}$ " wide x 8 $\frac{1}{2}$ " deep x 2 $\frac{1}{2}$ " high. Courier

Circle No. 17 on Reader Service Card

### 10-CHANNEL CB RADIO

The "Companion IV" is a 10-channel, plus p.a., CB two-way radio which is available with optional handset at no extra cost. The unit has front and bottom speakers which permit effective mounting in any position while providing increased volume level without distortion. The unit measures only 2 $\frac{1}{4}$ " high x 8 $\frac{1}{2}$ " wide x 6 $\frac{3}{8}$ " deep and weighs 3 $\frac{3}{4}$  pounds. It fits easily into tight spaces. It is especially adaptable to various dash installations and has a heavy chrome-plated die-cast front panel which blends with modern dashboard designs.

The radio comes complete with channel-9 crystals installed. Pearce-Simpson

Circle No. 18 on Reader Service Card

### COLORFUL CB TRANSCEIVERS

The new "Poly-Comm 23C" 23-channel, all-solid-state transceiver is now being offered in a choice of green, red, blue, or beige trim colors at no additional cost.

The new unit is a sensitive, compact transceiver which produces as much as 3 watts of audio at the speaker with as little as 0.15- $\mu$ V signal strength while its Collins mechanical filter provides a minimum of 30 dB adjacent-channel rejection according to the company.

The 23C can be used as a base station on its



PPI power supply; in car, truck, or boat with the 12-volt "Polyverter"; or as a portable unit. It also has provisions for attaching the company's all-solid-state tone alerter. Polytronics

Circle No. 19 on Reader Service Card

#### SOLID-STATE CB RADIO

A new solid-state CB radio, designed to provide motorists with low cost two-way communications, is now being marketed as the "Auto-Mate".

The set is a 12-channel (5-watt) transmitter/converter which receives in conjunction with a



conventional AM car radio and antenna. Emergency calls can be transmitted up to 10 miles. Calls are received over the car radio tuned to 1505 kHz.

The new unit is no larger than the tuning head of the average push-button car radio and draws no more current on standby than an electric auto clock. Installation takes only a few minutes. The "Auto-Mate" operates on any 12-volt negative-ground electrical system or any 6-volt negative-

ground system with a converter. The set also features built-in antenna matching to provide maximum transmit efficiency from the car radio antenna.

The radio comes with channel-9 crystal installed. Eleven additional channels are available for business or personal use. Pace

Circle No. 20 on Reader Service Card

#### 5-CHANNEL CB RADIO

The "Sentry II" is an all-solid-state, 5-channel CB radio which is being offered with either a conventional palm microphone or a telephone-type handset. The press-to-talk handset provides clearer transmission and reception and is as easy to use as a home phone.

The compact, 3-pound unit measures 7 $\frac{3}{4}$ " wide x 2 $\frac{1}{4}$ " high x 6" deep. It features a class-B push-pull audio amplifier; low power drain; a super-sensitive receiver, and a full-powered transmitter which provides 4 watts of output power.

The radio is supplied with channel-9 crystals for use in the HELP service. Pearce-Simpson

Circle No. 21 on Reader Service Card

#### TRANSISTORIZED DEPTH SOUNDER

A transistorized depth sounder that provides the dual functions of a 600-foot flashing-light-type sounder and a 75-fathom moving-chart



depth recorder has been introduced as the Model MR-203.

The recorder portion has a 3 $\frac{1}{2}$ -inch wide chart paper which is white for improved readability. The recorder's depth range of 75 fathoms is divided into three switchable phases: 0-25, 25-50, and 50-75 fathoms.

The MR-203 may be powered from 12, 24, or 32 volts d.c. Current drain is very low, according to the company. The instrument has been fully treated for resistance to the marine environment. Apelco

Circle No. 22 on Reader Service Card

## MANUFACTURERS' LITERATURE

### SWEEP-FREQUENCY MEASUREMENT

A new 6-page illustrated application note (No. 84) describing a new technique for making quick and accurate swept-frequency measurements of s.w.r. in coaxial systems at frequencies up to 18 GHz has been published.

Entitled "Swept SWR Measurement in Coax," the booklet details the instrumentation setup for making precision swept-frequency measurements. Basic theory is discussed along with the results of typical measurements. In addition, the publication covers sources of errors and describes how to eliminate load-reflection errors. Hewlett-Packard

Circle No. 140 on Reader Service Card

### TEST EQUIPMENT

A complete line of professional test instruments is described and illustrated in a new 12-page catalogue (No. 360). Included are tube and CRT checkers, color generators, analyzers, FM multiplex equipment, transistor-testing devices, a 5-inch oscilloscope, and several special-purpose instruments. Sencore

Circle No. 23 on Reader Service Card

### TANTALUM CAPACITORS

A new 4-page bulletin (No. GEA-8369) de-

For all your field servicing requirements . . .

# New *Weller*® battery operated soldering iron with tip temperature control



Here's a new Weller light-weight soldering iron that operates from any 12-volt battery or 12-14 volt AC/DC power supply. Meets all your needs in mobile communications soldering—in automotive, marine, aircraft and many other applications. Features Weller's patented "Temperature Sensing" system. Tip temperature is controlled at 700° F. Iron offers minimal power drain, long life, rapid recovery. 12-ft. power cord includes battery clips. Model TCP-12. **\$14<sup>60</sup>** list

Also available for 24-48 volt operation. Model TCP-24.

AT YOUR ELECTRONICS PARTS DISTRIBUTOR  
WELLER ELECTRIC CORP., Easton, Pa. WORLD LEADER IN SOLDERING TECHNOLOGY

CIRCLE NO. 96 ON READER SERVICE CARD



# 35 fascinating ways to spend your next 250 spare hours

Announcing the Spring 1967 edition of the "what-to-do-with-your-spare-time" problem-solver: the ELECTRONIC EXPERIMENTER'S HANDBOOK!

Roll up your sleeves, heat up the iron and get set to meet 35 of the most challenging, fun-to-build electronics projects you've ever seen . . . or assembled with your own two hands!

Included are: a transistorized auto-light minder • a \$2 intrusion alarm • a tape recorder echo chamber (for under \$10!) • a powerhouse 2-tube SW receiver • a solid-state scope calibrator • and even a supercharged salt shaker!

You get complete schematics, illustrations, parts lists and easy-to-follow instructions . . .



PLUS expert tips 'n techniques designed to build your electronics skill. You'll keep up with the latest advances in the field, learn many valuable professional methods and short-cuts . . . and develop that extra technical know-how that comes only from practical, firsthand experience.

Don't chance missing your copy of the Spring 1967 ELECTRONIC EXPERIMENTER'S HANDBOOK. Use the coupon below to order yours today! **only \$1.25**

Get the handsome LEATHERFLEX-BOUND edition for just \$3 postpaid! The Spring 1967 ELECTRONIC EXPERIMENTER'S HANDBOOK is also available in a splendid deluxe edition. Rugged Leatherflex cover provides lasting protection yet is softly textured and gold-embossed for the look of elegance. A collector's item—a superb addition to your electronics bookshelf. And it's yours, for just \$3 postpaid, when you check the appropriate box on the order form.



ZIFF-DAVIS SERVICE DIVISION • DEPT. EEH-S  
595 Broadway • New York, N. Y. 10012

OK! Send me the all-new SPRING 1967 ELECTRONIC EXPERIMENTER'S HANDBOOK.

\$1.25 enclosed, plus 15¢ for shipping and handling. Send me the regular edition. (\$1.75 for orders outside the U.S.A.)

\$3.00 enclosed. Send me the Deluxe Leatherflex-bound edition, postpaid. (\$3.75 for orders outside the U.S.A.) Allow three additional weeks for delivery.

name \_\_\_\_\_ please print EW-87

address \_\_\_\_\_

city \_\_\_\_\_ state \_\_\_\_\_ zip \_\_\_\_\_

**PAYMENT MUST BE ENCLOSED WITH ORDER**

Boy, do I have spare time! Send me the big Fall 1966 edition, too! I want the  regular edition  Deluxe Leatherflex-bound edition. (Prices same as above.)

scribing a line of wet-slug tantalum capacitors is now available. Included are subminiature devices for industrial and military applications and miniature tubular types for military use.

Information on outline dimensions, volumetric efficiency of wet slug vs solid tantalum capacitors, and microfarad capability is provided. General Electric

Circle No. 141 on Reader Service Card

## TINY INDICATOR LIGHTS

A complete line of ultra-miniature "Datalite" indicator lights suitable for computer, data-processing, and automation applications is presented in a new 12-page, fully illustrated catalogue (No. L-160F).

Features include a choice of plug-in incandescent or neon lamp cartridges, a wide range of lens colors, and custom legend marking (hot-stamped or engraved). Dialight

Circle No. 142 on Reader Service Card

## ELECTRICAL WIRE

A new 44-page catalogue covering an extensive line of electrical wire, cable, and cord has just been released.

The publication includes technical data on military electronic wire as well as popular commercial types of wire and cable. Characteristics are listed in easy-to-read tabular form. There is a military spec index and an alphabetical listing to facilitate locating the various items. Standard Wire

Circle No. 143 on Reader Service Card

## DATA ON LECTERN

An engineer's and architect's specification sheet (LASS-500) has been published on the "Ampli-Vox" sound column lectern, Model S-500.

The brochure contains complete information on the battery-operated p.a. system including technical specs on the amplifier, microphone, and loudspeaker as well as the unit as a whole. Perma-Power

Circle No. 24 on Reader Service Card

## H.V. TEST EQUIPMENT

A new catalogue listing a completely redesigned line of high-voltage test equipment has just been issued.

Catalogue #167 contains complete technical data, photos, prices, and delivery information. Included are 1 to 300 kV a.c. and d.c. power packs, power supplies, and test sets for dielectric strength, breakdown, leakage, corona, and continuity tests. Peschel

Circle No. 144 on Reader Service Card

## CCTV SYSTEM BULLETIN

A four-color, eight-page bulletin (GEA-8059) describing a new economy closed-circuit TV system has just been issued. It includes technical specifications on both the TE-23 solid-state camera and TH-31 monitor making up the system.

Included in the bulletin are descriptions of the CCTV package as a security surveillance system and as a communication system including applications such as monitoring apartment entrances, banks, hospital rooms, parking lots, and warehouses. General Electric

Circle No. 25 on Reader Service Card

## MAGNETIC SHIELDING ALLOYS

Technical information on a new line of magnetic shielding alloys is provided in a brochure addressed to engineers and designers. In addition to listing a wide range of coercive forces, the brochure includes magnetization as well as attenuation curves for foils and sheet materials. Primec

Circle No. 145 on Reader Service Card

## PHASE-SHIFT MEASUREMENTS

A new 11-page application note describing techniques for making phase-shift measurements at low frequencies is available on request.

Application Note No. 81 covers frequencies ranging from 60 kHz to lower than 0.01 Hz. The booklet discusses how the phase delay encountered by a signal in passing through the

device under test, such as a servo system, is measured by oscilloscope comparison with the variable phase output of the company's Model 203A variable phase function generator. A method of overcoming flicker in the scope display at very low frequencies is also described. Hewlett-Packard

Circle No. 146 on Reader Service Card

## CONVERTER DESIGN

The principal design considerations for high-speed, wide-band a.c.-to-d.c. converters are discussed in Technical Paper 724. The text is oriented to the requirements of a.c.-to-d.c. converters at the input of high-accuracy digital voltmeters.

Particular attention is paid to questions of frequency response, settling time, stability, accuracy, and convenience. The discussion deals primarily with the average-responding converters used to extend the measuring power of d.v.m.'s from d.c. volts to a.c. volts. Dana

Circle No. 147 on Reader Service Card

## SOLDERLESS TERMINALS

A 28-page, four-color catalogue, T-90, covering a complete line of solderless terminals and connectors for all types of industry applications is now available.

The catalogue includes detailed instructions for the selection and use of the correct terminals and crimps to assure a perfect termination or splice for every wiring need. Vaco

Circle No. 26 on Reader Service Card

## COMMUNICATIONS TEST EQUIPMENT

A 12-page brochure entitled "Radio Communications Test Equipment" has been issued to assist all those who work with two-way radio systems. Pictured and described are various frequency meters, station monitors, signal generators, scopes, portable test sets, a.c. voltmeters, battery testers, d.c. multimeters, tone oscillators, pulse generators, alignment meters, plus accessories for use with the instruments and in hooking up the systems. Motorola

Circle No. 27 on Reader Service Card

## PHOTOELECTRIC SYSTEMS

Complete specifications on a new line of low-cost integral two-part and remote three-part miniature and subminiature photoelectric systems for material handling, packaging, production, and processing control are included in a new 8-page bulletin.

The bulletin includes a guide for selecting among the many system combinations offered for operating speeds of 1200, 600, or 120 times a minute at 12 inches or less up to 25 feet. Sigma Instruments

Circle No. 28 on Reader Service Card

## REED RELAY CATALOGUE

A short-form, four-page data sheet covering a comprehensive line of standard reed relays has just been issued. Featured is the SMR series of magnetically shielded, encapsulated miniature reed relays for high density, PC-board applications. Integrated Electronics

Circle No. 148 on Reader Service Card

## PHOTO CREDITS

Page	Credit
32 (top)	Western Electric Co.
32 (center)	Westinghouse Electric Co.
32 (bottom)	Rodio Corporation of America
33 (top)	Bulova Watch Company
33 (center)	IBM
33 (bottom left)	General Motors Corp.
33 (bottom right)	Philco Div.
42 (bottom right)	Lockheed Electronics Co.
43, 44	Airborne Instruments Laboratory
45	Sonotone Corp.
49	Nexus Research Lab

# ELECTRONICS MARKET PLACE

**COMMERCIAL RATE:** For firms or individuals offering commercial products or services. 70¢ per word (including name and address). Minimum order \$7.00. Payment must accompany copy except when ads are placed by accredited advertising agencies. Frequency discount: 5% for 6 months; 10% for 12 months paid in advance.

**READER RATE:** For individuals with a personal item to buy or sell. 40¢ per word (including name and address). No Minimum! Payment must accompany copy.

**GENERAL INFORMATION:** First word in all ads set in bold caps at no extra charge. Additional words may be set in bold caps at 10¢ extra per word. All copy subject to publisher's approval. **Closing Date:** 1st of the 2nd preceding month (for example, March issue closes January 1st). Send order and remittance to: Hal Cymes, **ELECTRONICS WORLD**, One Park Avenue, New York, New York 10016

## FOR SALE

**JUST starting in TV service?** Write for free 32 page catalog of service order books, invoices, job tickets, phone message books, statements and file systems. Oelrich Publication, 6556 W. Higgins Rd., Chicago, Ill. 60656.

**GOVERNMENT Surplus Receivers, Transmitters, Snooperscopes, Radios, Parts, Picture Catalog 25¢.** Meshna, Nahant, Mass. 01908.

**METERS—Surplus, new, used, panel and portable.** Send for list. Hanchett, Box 5577, Riverside, Calif. 92507.

**INVESTIGATORS, FREE BROCHURE, LATEST SUBMINIATURE ELECTRONIC SURVEILLANCE EQUIPMENT.** ACE ELECTRONICS, 11500-J NW 7TH AVE., MIAMI, FLA. 33168.

**R.F. CONVERTERS** World's largest selection. Also CCTV cameras, etc. Lowest factory prices. Catalog 10¢. Vanguard, 196-23 Jamaica Ave., Hollis, N.Y. 11423.

**CONVERT** any television to sensitive big-screen oscilloscope. Only minor changes required. No electronic experience necessary. Illustrated plans, \$2.00. Relco-A22, Box 10563, Houston, Texas 77018.

**SUDYMONT** acoustic baffles. Plans \$5.95; Baffle \$26.95; with cabinet from \$39.95. Send speaker size. **SUDYMONT**, 120 Liberty Str., NYC 10006.

**JAPAN & Hong Kong Electronics Directory.** Products, components, supplies. 50 firms—just \$1.00. Ippano Kaisha Ltd., Box 6266, Spokane, Washington 99207.

**FREE ELECTRONICS** (new and surplus) parts catalog. We repair multimeters. Bigelow Electronics, Bluffton, Ohio 45817.

**DETECTIVES!** Free brochures! Electronic Surveillance devices. **SILMAR ELECTRONICS**, 3476 N.W. 7th Street, Miami, Florida 33125.

**MUSIC LOVERS, CONTINUOUS, UNINTERRUPTED BACKGROUND MUSIC FROM YOUR FM RADIO, USING NEW INEXPENSIVE ADAPTOR.** FREE LITERATURE. **ELECTRONICS**, 11500-Z NW 7TH AVE., MIAMI, FLORIDA 33168.

**SURVEILLANCE EQUIPMENT—NEW HIGH PERFORMANCE SUBMINIATURE MODELS. ELECTRONIC COUNTERMEASURE DEVICES TO PROTECT PRIVACY.** FREE DATA: **SECURITY ELECTRONICS-EW**, 15 EAST 43RD STREET, NEW YORK, N.Y. 10017.

**CRYSTALS . . . largest selection in United States at lowest prices.** 48 Hr. delivery. Thousands of frequencies in stock. Types include HC6/U, HC18/U, FT-241, FT-243, FT-171, etc. Send 10¢ for catalog with oscillator circuits. Refunded on first order. Jan Crystals, 2400E Crystal Dr., Fort Myers, Fla. 33901.

**JAPANESE PRODUCTS CATALOG** by air mail \$5, sea \$3. Intercontinental, CPO 1717, Tokyo, Japan.

**POLICE RADIO.** Hear all police calls, fire departments, Sheriffs, taxis, ambulances, Highway Patrol. New 5 band portable radio and direction finder. Free Booklet. NovaTech, Dept. 234, Redondo Beach, Calif. 90278.

**TREASURE HUNTERS!** Prospectors! Relco's new instruments detect buried gold, silver, coins. Kits, assembled models. Transistorized. Weighs 3 pounds. \$19.95 up. Free catalog. Relco-A22, Box 10839, Houston, Texas 77018.

**ELECTRONIC PARTS!** Components, transistors, diodes, kits, relays, and many special items. Guaranteed. Send 25¢ for 100 page catalog. General Sales Co., P.O. Box 2031, Freeport, Texas 77541.

**MESHNA'S TRANSISTORIZED CONVERTER KIT.** Converts car radio to receive police and fire. 30-50MHz and 100-200MHz. (one MHz Tuning) \$5.00 with easy to follow step instruction. Meshna, No. Reading, Mass. 01864.

**INVESTIGATORS:** Free brochures, latest professional electronic surveillance equipment. **DD LABS**, P. O. Box 2311, Sunnyvale, California 94087.

**INTEGRATED CIRCUIT KITS; COMPUTER LOGIC;** Parts; Others. Catalogue free. **KAYE ENGINEERING**, Box 3932, Long Beach, California 90803.

**INTRODUCING** new line of **MORRISON** speaker systems. Introductory prices, free brochure, write: Morrison Speaker Systems, Box 6203, Coralville, Iowa 52240.

## FREE ARCTURUS CATALOG

A trusted name in electronics since 1925  
Electronic parts, tubes. Wholesale.  
Thousands of items. Unbeatable prices.  
**ARCTURUS ELECTRONICS CO.**  
502-22nd St., Dept. EW, Union City, N.J. 07087

**REFURBISHED LAB EQUIPMENT—Hewlett Packard 400D 1mv-300v f.s. VTM \$140; 410A AC/DC, Ohms, RF to 700 MHz \$140; 410B AC/DC, Ohms, RF to 700 MHz \$75; 150A Scope with dual trace, 10MHz \$495; 204A Oscillator 20-20-KHz, battery op. \$95; 212A Pulser, .07-10 usec. \$175; 475B Tunable Bolometer Mount \$75; Textronix 511, 512, 513, 514 Scopes From \$260; L & N Galvos From \$45; Hughes Memoscope, 104D \$350; Key Electric Rada Pulser, IF 30 & 60 MHz \$275; Lambda 1532M & 1512M, 100-300Vdc @ 1.5a \$95; Sensitive Research Model L AC Standard \$395; Sensitive Research, Weston, Greibach Meters, Manuals furnished on most equipment, write for complete listing. **HARLAN LABS**, 7917 Balboa Ave., San Diego, Calif. 92111 714-278-1700.**

**NEW!** Subminiature wireless listening device. Operates without any antenna. Range is several hundred feet. Easily concealed module measures 1"x2"x1" and uses standard FM receiver. Wired unit—\$25.00, Kit form—\$15.00 (hearing aid mike incl). Complete instructions, guaranteed. **Norrisonic Co.**, 9803-23rd NW Seattle, Washington 98107.

**ELECTRONIC Ignition.** Kits, components, systems. Diagrams. Anderson Engineering, Epsom, N.H. 03239.

## Electronics World SUBSCRIBER SERVICE

Please include an address label when writing about your subscription to help us serve you promptly. Write to: Portland Place, Boulder, Colo. 80302

### CHANGE OF ADDRESS:

Please let us know you are moving at least four to six weeks in advance. Affix magazine address label in space to the right and print new address below. If you have a question about your subscription, attach address label to your letter.

### TO SUBSCRIBE:

- Check boxes below.
- New  Renewal
- 5 years \$21
- 3 years \$15
- 1 year \$6

### SPECIFY:

- Payment enclosed—  
You get 1 extra issue per year as a **BONUS!**
- Bill me later.

AFFIX LABEL

If you have no label handy, print OLD address here.

name \_\_\_\_\_

city \_\_\_\_\_

address \_\_\_\_\_

state \_\_\_\_\_

zip-code \_\_\_\_\_

please print

Add'l postage: \$1 per year outside U.S., its possessions & Canada.

name \_\_\_\_\_ please print \_\_\_\_\_ 0170

address \_\_\_\_\_

city \_\_\_\_\_

state \_\_\_\_\_ zip-code \_\_\_\_\_

## GET IT from GOODHEART!

### EVERYTHING UNCONDITIONALLY GUARANTEED!

#### REGULATE LINE VOLTS AT SURPLUS PRICES:

All 1 ph. All 95-130 v in unless stated otherwise. CV xfms, isolated secondaries, regulation 1%  
 500 va \$37.50. With max. 3% harmonics \$49.50.  
 1 kva \$89.50. Following are Electronics types, regulation 0.1% max. harmonics 3%  
 500 va \$89.50 1 kva \$99.50 2 kva \$179.50  
 2.5 kva \$199.50 3 kva \$279.50 5 kva \$249.50  
 5 kva 190-260 v in, 220-240 v out 1 ph. . . . \$349.50.  
 Electromechanical types follow: regulation 1% to 1%. Have no harmonics. Life tests more than 100 years. Line frequency has very little effect on them.  
 2.7.5 kva 190-260 v to 220-240 v 1 ph. . . \$395.00.  
 27.5 kva 190-260 v to 220-240 v 1 ph. . . \$495.00.

#### MAKE 400 CYCLES FROM 60 CYCLE INPUT:

100 va 1 ph electronic TIC 400AR: 380-420 cy, 90-130 v out, w/callb. cert. & book . . . . . \$125.00  
 500 va 3 ph electronic 1 ph in, Behlman . . . . . 595.00  
 6.25 kva (5 kw at 0.8 pf) rotary, synchronous, Inet Lech RX409 w/ 3 ph 48 v 4-wire 60 v motor. 120/240 v out, 1 ph. Excit. exts, 1% mag-amp volt. regul., Pot. stat. Vc control, and control panel, all in one neat cabinet. With book. Regular \$500.00. From us, 2000 lbs job Bremerton, Wa., only . . . . . 595.00

#### UNUSUAL POWER SUPPLIES: DIGIT DIALING!

**Fluke 301C:** Dial volts you want by digits with resolution 500 uv and accuracy 0.1% to 1012 v, 0-400 ma dc. Line, load, & per-hour stabil. .05%. Max ripple 2 mv. In catalog today \$985.00. W/book & NBS-traceable calib. certificate . . . . . \$595.00  
**Fluke 407C:** Metered 0.655 v, 0-500 ma dc, plus bias supply 0-250 v. Knob-digit setting resolution 2 mv. Line, load & per-hour stability 0.1%. Max. ripple 1 mv. rms. Regular \$ 5.00. With book and callb. certifi. . . . . 175.00  
**Kintel digit-dial volts w/callb.** .02%, regul. .01% line. .00% load, less than 0.5 mv ripple.  
 W/book and callb. certificates  
 =30B25 is 1.02 to 302 v at 0-250 ma dc . . . . . 350.00  
 =50B25 is 1.02 to 602 v at 0-250 ma dc . . . . . 450.00  
**Dial Current:** North Hills CS-120. Dial 0-10 ma dc in steps of 0.1 microamp; up to 2250 v, 0.1% regul. Esc. for ETV tests . . . . . 295.00  
**Dial 0-20,000 volts w/2 detent and 1 cont. resol. dial.** Up to 6 ma dc. Metered and filtered. Smith-Florence . . . . . 170.00  
**Dial Bias 0-100 v dc in steps of 0.1 v, 0.1% accurate.** Test-instrument #14044 Decade Bias Supply, useful for low-current meter calibration . . . . . 49.50

**ALL-BAND SSB RCVR BARGAIN:** Hallicrafters R-43/ARR-7, 550 kc to 43 mc continuous. Voice, CW, MCW, aligned, grid, w/book, 2-RF, 2-IF's, sensitivity choices. Less pwr sply. . . . . 149.50  
 80 cy pwr sply: \$30. SSB product detector: \$20

**TIME PAY PLAN:** Any purchase totaling \$160.00 or more, down payment only . . . . . 10%

**ATTENTION Buyers of LAB Test Equipment:** The above is a small sampling of our terrific inventory. We ALSO BUY! We want Tektronix scopes, Hewlett-Packard equip., Aeronaut, radio-shop equip., etc. . . . . AND Military Communications of all kinds

## R. E. GOODHEART CO. INC.

Box 1220-A, Beverly Hills, Calif. 90213

Phones: Area 213, office 272-5707, messages 275-5342

CIRCLE NO. 114 ON READER SERVICE CARD



# G&G CATALOG!

**NEW**

24 Pages - the BEST in Military Electronic Gear. SEND NOW FOR YOUR COPY! Please include 25¢ Refunded with first order.

## AN/APR-4Y FM & AM RECEIVER "FB" FOR SATELLITE TRACKING!

High precision lab instrument, for monitoring and measuring frequency and relative signal strength, 38 to 4000 Mc. In 5 tuning ranges. For 110 V 60 cycle AC. Built-in power supply. Original circuit diagram included. Checked out, perfect, LIKE NEW ..... \$88.50  
All Tuning Units Available for Above



BC-929 3-Inch Scope, with all tubes, LIKE NEW ..... \$16.95

Conversion instructions, with diagram, for 110 V AC operation ..... \$ .65

BC-733 (SATELLITE) RECEIVER, 108 Mc, AM, Crystal-controlled on 6 preset frequencies. Complete with 10 tubes, crystals and schematic. Exc. Used ..... \$8.95

T-23/ARC-5 TRANSMITTER, 100 to 156 Mc. Less tubes and crystals, Used ..... \$5.95

BC-603 FM RECEIVER, 35-50 Mc. 10 preset push-button channels or manual tuning. Complete with 10 tubes, NEW ..... \$52.50  
Technical Manual for above ..... \$2.50  
DM-34 12V Power supply for above. New..... 4.45

BC-604 FM TRANSMITTER, 20-27.9 Mc., 30-watts output. 10 crystal-controlled channels. Complete with 8 tubes, NEW ..... \$12.50  
DM-37 28VDC Dynamotor, NEW..... 4.75

R-4/ARR-2 RECEIVER, 234-258 Mc, Tunable. Complete with 11 tubes, NEW ..... \$11.95

BC-645 TRANSCEIVER 435 to 500 Mc, convertible for Ham or Citizens' bands, Voice or Code. Brand new, with 15 tubes ..... \$16.95  
Dynamotor, Antenna, Plugs, All accessories available.

### SCR-274-N, ARC-5 COMMAND SET HQ!



Freq. Range	Type	Exc. Used	BRAND NEW
<b>RECEIVERS, Complete with Tubes</b>			
190-550 Kc.	BC-453	\$18.95	\$23.50
3-6 Mc.	BC-454	\$16.50	\$21.50
6-9.1 Mc.	BC-455	\$14.95	\$19.95
1.5-3 Mc.	T-18	\$16.95	\$21.50
<b>TRANSMITTERS, Complete with Tubes</b>			
4-5.3 Mc.	BC-457	\$ 6.95	\$11.95
5-3.7 Mc.	BC-458	\$ 6.95	\$12.95
7-9.3 Mc.	BC-459	\$17.95	\$22.50
1.5-3 Mc.	T-19	\$10.50	\$14.95
<b>MODULATOR, Complete with 3 Tubes</b>			
Voice	BC-456	\$ 2.75	\$ 4.95
All Command Set Accessories in Stock			

SCR-625 MINE DETECTOR ..... \$32.50  
EE-8 FIELD PHONES, Exc. Used, Each ..... \$16.95  
BC-221 Freq. Meter, Modulated, Exc. Used, \$129.50  
BC-221 Freq. Meter, Unmodulated, Exc. Used \$79.50  
LM Freq. Meter, Exc. Used ..... \$79.50  
EC-1206-C Beacon Rcvr, 200-400 Kc. NEW. \$12.95  
SCR-522 Transmitter-Receiver, Like New..... \$39.50

TG-34A CODE KEYS ..... \$24.50  
Brand New in original carton ..... \$18.95  
Exc. Used ..... P.U.R.  
Franchise Tapes available, with Keyer ..... P.U.R.

Please include 25¢ Deposit with order—Balance C.O.D., or Remittance in Full. 50¢ Handling Charges on all orders under \$5.00. All shipments F.O.B. Our Warehouse, N.Y.C. All Merchandise subject to Prior Sale and Price Change.

## G & G RADIO SUPPLY COMPANY

Telephone: (212) CO 7-4605  
75-77 Leonard St., New York, N.Y. 10013

VHF FM Converter 156-163 MHz, output in Broadcast Band, Name Brand, Special \$35. Postpaid, satisfaction guaranteed. Research, Box 334A, Cape Canaveral, Fla. 32920.

SAVE ON DIODES. If you use germanium or silicon diodes in quantities of 5000 to a million, get our low, low prices. Send specs or request samples. Ruland Manufacturing Co., Watertown, Mass. 617-924-8000.

## ELECTRONICS ENGINEERING AND INSTRUCTION

REI First Class Radio Telephone License in (5) weeks Guaranteed. Tuition \$295.00. Job placement free. (KANSAS CITY) R.E.I., 3123 Gillham Road, Kansas City, Missouri, Telephone WE1-5444. (SARASOTA) R.E.I., 1336 Main Street, Sarasota, Florida 33577, Telephone 955-6922.

HIGHLY—effective home study review for FCC commercial phone exams. Free literature! COOK'S SCHOOL OF ELECTRONICS, P.O. Box 36185, Houston, Texas 77036.

## CLASSIFIED ADVERTISING ORDER FORM

Please refer to heading on first page of this section for complete data concerning terms, frequency discounts, closing dates, etc.

1	2	3	4	5
6	7	8	9	10
11	12	13	14	15
16	17	18	19	20
21	22	23	24	25
26	27	28	29	30
31	32	33	34	35

\_\_\_\_\_ Words { @ .40 Reader Rate } = \$ \_\_\_\_\_  
{ @ .70 Commercial Rate }  
Insert \_\_\_\_\_ time(s) Total Enclosed \$ \_\_\_\_\_

NAME \_\_\_\_\_

ADDRESS \_\_\_\_\_

CITY \_\_\_\_\_ STATE \_\_\_\_\_ ZIP \_\_\_\_\_

### SIGNATURE

WORD COUNT: Include name and address. Name of city (Des Moines) or of state (New York) counts as one word each. Zip Code numbers not counted. (Publisher reserves right to omit Zip Code if space does not permit.) Count each abbreviation, initial, single figure or group of figures or letters as a word. Symbols such as 35mm, COD, PO, AC, etc., count as one word. Hyphenated words count as two words. EW-867

WANTED! TV—Radiomen to learn aircraft electronics servicing. Numerous job openings everywhere. Write: ACADEMY AVIONICS, Reno/Stead Airport, Reno, Nevada 89500.

ASSOCIATE Degree in Electronics Engineering earned through combination correspondence-classroom educational program. Free brochure. Grantham Technical Institute, 1505 N. Western Ave., Hollywood, Calif. 90027.

ELECTRONICS! Associate degree—29 months. Technicians, field engineers, specialists in communications, missiles, computers, radar, automation. Start September, February. Valparaiso Technical Institute, Dept. N, Valparaiso, Indiana 46383.

LEARN ELECTRONIC ORGAN SERVICING at home. All Makes including transistors. Experimental kit—troubleshooting. Accredited NHSC. Free Booklet. MILES BRYANT SCHOOL, 3631 Stockton, Dept. A, Sacramento, Calif. 95820.

HIGHLY effective home study course in Electronics Engineering Mathematics with circuit applications. Earn your Associate in Science Degree. Free literature. COOK'S INSTITUTE OF ELECTRONICS ENGINEERING, P.O. Box 36185, Houston, Texas 77036.

FCC LICENSE training by correspondence. Low cost, pay-as-you-go plan. Free particulars. The Willard Foundation, Department EW, P.O. Box 1049, Washington, N.C. 27889.

FCC First Class License in six weeks—nation's highest success rate—approved for Veterans Training. Write Elkins Institute, 2603C Inwood Road, Dallas, Texas 75235.

## EDUCATIONAL OPPORTUNITIES

LEARN While Asleep, hypnotize with your recorder, phonograph. Astonishing details, sensational catalog free! Sleep-Learning Association, Box 24-ZD, Olympia, Washington 98501.

USED Correspondence Courses and Books sold and rented. Money back guarantee. Catalog free (Courses Bought). Lee Mountain, Pisgah, Alabama 35765.

LEARN WHILE ASLEEP. Miraculously build Mind Power, achieve Self Confidence, improve Health, gain Success. Method 92% effective. Details free. ASR Foundation, Box 7021EG Henry Clay Station, Lexington, Kentucky 40502.

## U.S. GOV'T ELECTRONIC SURPLUS

• Nationally Known-World Famous SURPLUS CENTER offers finest, most expensive, Government Surplus electronic units and components at a fraction of their original acquisition cost.

ORDER DIRECT FROM AD or WRITE FOR CATALOGS

### STANDARD DIAL TELEPHONE

• (ITEM #715) -- Standard, commercial telephone same as used throughout U.S.A. Attractive polished black, like new condition. Use as extension phone to private systems or connect several phones together for local intercom system. Full instructions are furnished. Wt. 9 lbs. Original Cost \$24.50. F.O.B. \$5.95



### STEP-BY-STEP AUTOMATIC SWITCH

• (ITEM #738) -- Amazing "up-and-around", electro-magnetic telephone switch. Dial any bank pair from 1 to 100. Make your own telephone system. Can also be used to remotely control up to 100 circuits over a single pair of wires.  
• One of our FOUR STAFF bargains. Comes complete with data, one dial and one line bank. Size, 5" x 7" x 15". Wt. 16 lbs. Cost Gov't Over \$75.00. Complete; Switch, cover, dial, line bank, instructions..... F.O.B. \$9.95

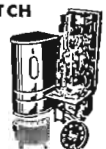

### TYPICAL BUYS FROM OUR 1967 CATALOGS

- \$ 350.00 - Geared 2-hp Battery Golf Car Motor ..... \$24.95
- \$ 15.00 - Westinghouse DC Ammeter, 0 to 300 ..... \$ 7.11
- \$ 40.00 - Vacuum/Pressure Pump, 12-VDC ..... \$11.95
- - - 80-MW Walkie-Talkies, Per Pair ..... \$19.60
- - - Deluxe, Multi-Range, AC/DC Tester ..... \$ 8.98
- \$4000.00 - Carrier Telephone Amplifier System ..... \$13.91

## SPECIAL SALE Correspondence Course in ELECTRICAL ENGINEERING



Sells For \$10.79 in U.S.A. \$8.79 Postpaid Outside U.S.A.  
• (ITEM #A1B1) -- Wonderful chance to obtain technical training at Amazing Low Cost! Lincoln Engineering School has suspended its Correspondence Courses because of increased operating costs. We offer a limited number of the school's complete Electrical Engineering Course but without the examination paper grading service. The course consists of 14 lesson unit books. Each book has the regular exams, and in a separate section, "Standard Answers" to each exam question.  
• Course is well written, easy to understand, profusely illustrated. Reader's Digest size, easy to carry and study in spare time. Many Lincoln Engineering School students holding excellent jobs as a result of L.E.S. training. Course contains latest information on transistors, silicon diodes, etc. Additional book on how to build and operate a "Home Laboratory and Experimental Bench" furnished with each course.

SEND 25¢ COIN OR STAMPS FOR 3 MAIN CATALOGS  
All Items FOB Lincoln Money Back Guarantee

## SURPLUS CENTER

DEPT. EW-087 LINCOLN, NEBR. 68501

## TUBES

FREE Catalog. Electronic parts, tubes. Wholesale. Thousands of items. Unbeatable prices. Arcturus Electronics ZD, 502-22 St., Union City, N.J. 07087.

**RECEIVING & INDUSTRIAL TUBES, TRANSISTORS, All Brands—Biggest Discounts.** Technicians, Hobbyists, Experimenters—Request FREE Giant Catalog and SAVE! ZALYTRON 469 Jericho Turnpike, Mineola, N.Y. 11501.

**TUBES, SEMICONDUCTORS, ELECTRONIC EQUIPMENT & COMPONENTS.** Quality merchandise only! Serving engineers, Purchasing Agents, TV/HiFi Servicemen and Hams for 20 years. Write for Catalog or call 212-WA 5-7000. BARRY ELECTRONICS, 512 Broadway, New York, N.Y. 10012.

**TUBES—33¢ each.** Year guarantee. Tuner Cleaner \$1.09. Free catalog. Cornell, 4213-W University, San Diego, Calif. 92105.

**DON'T BUY TUBES** — Radio, TV-Xmitting, special-purpose types until you get our price list! Lowest prices in U.S.A. 5,000 types—Guaranteed Brand New. Send postcard for TV—Special Purpose Price List. UNITED RADIO COMPANY, P.O. BOX 1000, NEWARK, N.J. 07101.

## WANTED

**QUICKSILVER,** Platinum, Silver, Gold. Ores Analyzed. Free Circular. Mercury Terminal, Norwood, Mass. 02062.

**QUICK CASH . . .** for Electronic Tubes, Semiconductors, Equipment (Receivers, Transmitters, Scopes, Vacuum Variables, etc.) Send lists now! Write: BARRY ELECTRONICS, 512 Broadway, New York, N.Y. 10012 (212-WA 5-7000).

**WANTED TO BUY—TV tuners.** Any make, any quantity. Write, J. W. Electronics, Box 51B, Bloomington, Indiana 47401.

## INVENTIONS WANTED

**INVENTORS.** We will develop, help sell your idea or invention, patented or unpatented. Our national manufacturer clients are urgently seeking new items for outright cash sale or royalties. Financial assistance available. 10 years proven performance. For free information, write Dept. 42, Wall Street Invention Brokerage, 79 Wall Street, New York, N.Y. 10005.

**PATENT SEARCHES, \$6.00! FREE "Invention Record"/Information.** Miss Hayward. 1029HE Vermont, District of Columbia 20005.

**INVENTIONS — IDEAS** developed Cash/Royalty Sales. Member: United States Chamber Commerce. Raymond Lee, 130-GE West 42nd, New York City 10036.

**INVENTIONS wanted!** Highest cash or royalties. Financial assistance. Free analysis. International Invention Institute, Dept. 31, 160 Broadway, New York, New York 10038.

**INVENTORS!** Get your "Little Piggy" to market. Highest cash or royalties. New York Invention Service, Dept. 13, 160 Broadway, New York, N.Y. 10038.

## DO-IT-YOURSELF

**PROFESSIONAL ELECTRONICS PROJECTS** — \$1.00 up. Catalog 25¢. PARKS, Box 25565B, Seattle, Wash. 98125.

## TAPE RECORDERS

**BEFORE** renting Stereo Tapes, try us. Postpaid both ways — no deposit — immediate delivery. Quality—Dependability—Service—Satisfaction—prevail here. If you've been dissatisfied in the past, your initial order will prove this is no idle boast. Free Catalog. Gold Coast Tape Library, Box 2262, Palm Village Station, Hialeah, Fla. 33012.

**STEREO TAPES.** Save up to 60% (no membership fees, postpaid anywhere USA). Free 60-page catalog. We discount batteries, recorders, tape accessories. Beware of slogans "not undersold," as the discount information you supply our competitor is usually reported to the factory. SAXITONE, 1776 Columbia Rd., Washington, D.C. 20009.

**RENT Stereo Tapes—Over 2,500 Different—**all major labels—free brochure. Stereo-Parti, 1616 —E. W. Terrace Way, Santa Rosa, California 95404.

**TAPE RECORDER SALE.** Brand new, nationally advertised brands, \$10.00 above cost. Arkay Sales, 1028-B Commonwealth Avenue, Boston, Mass. 02215.

**Hi-Fi Components, Tape Recorders** at guaranteed "We Will Not Be Undersold" prices. 15-day money-back guarantee. Two-year warranty. No Catalog. Quotations Free. Hi-Fidelity Center, 239 (LT) East 149th Street, New York 10451.

**RENT STEREO TAPES—75¢ week.** Catalog. Art's, 1442 Blaze, Simi, Calif. 93065.

## PRINTING

**FREE Booklet** — "Secrets of Cutting Printing Cost", Dept. 1, 305 S. 4th, Springfield, Illinois 62701.

## HIGH FIDELITY

**FREE!** Send for money saving stereo catalog #E8W and lowest quotations on your individual component, tape recorder or system requirements. Electronic Values Inc., 200 West 20th Street, N.Y., N.Y. 10011.

**Hi-Fi Components, Tape Recorders** at guaranteed "We Will Not Be Undersold" prices. 15-day money-back guarantee. Two-year warranty. No Catalog. Quotations Free. Hi-Fidelity Center, 239 (L) East 149th Street, New York 10451.

**HIFI EQUIPMENT—Get Our "ROCK BOTTOM" prices on NAME BRAND amplifiers—tuners—tape-recorders — speakers FRANCHISED — 59 YEARS IN BUSINESS.** Write for this month's specials—NOW! Rabson's 57th St., Inc., Dept. 569, 119 W. 57th St., New York, New York 10019.

**LOW, LOW quotes:** all components and recorders. Hi-Fi, Roslyn, Penn. 19001.

**Hi-Fi components, tape recorders, sleep learn equipment, tapes.** Unusual Values. Free catalog. Dressner, 1523 R Jericho Turnpike, New Hyde Park, N.Y. 11040.

**EVERYONE** can afford **HIGH-FIDELITY** components—because of our **DISCOUNT** policy. Insured guaranteed shipments — Factory sealed cartons—**FRANCHISED.** Send for our **LOW-LOW** quote today. Sound and Sight Audio, Inc., 106 West 32 Street, New York, N.Y. 10001.

## GOVERNMENT SURPLUS

**JEEPS** Typically From \$53.90. . . Trucks From \$78.40. . . Boats, Typewriters, Airplanes, Electronics Equipment, Photographic Equipment, used. 100,000 Bargains Direct From Government. Complete Sales Directory and Surplus Catalog \$1.00 (Deductible First \$10.00 Order). Surplus Service, Box 820-K, Holland, Michigan 49423.

## RUBBER STAMPS

**RUBBER ADDRESS STAMP \$1.50. SIGNATURE \$2.88. FREE CATALOG.** JACKSON PRODUCTS, 1433 WINNEMAC, CHICAGO, ILL. 60640.

## GREGORY ELECTRONICS Reconditioned & Used FM 2-WAY RADIO SAVINGS

Partial list—Send for New '67 Catalog

### Voice Commander



132 to 172 MC, 1W 9.5" x 5.3" x 1.7" Lowest price ever, including brand New Rechargeable Nickel Cadmium Battery Pack

**\$148**

If crystal & tuning is desired add \$45.00

Battery charger for these units \$16.00

Write for Quantity Prices

**VOICE COMMANDER**

Monitor Receiver only—**\$78**  
Tuned & Crystalled with dry Batteries

**RCA CMV1D—150-170 mc.** Wide Band, makes excellent monitor receiver, complete accessories . . . . . **\$28**

**MOTOROLA P33 Series Pack Set 5 Watt 150-170 MC with Nicad Supply and Nicad Batteries . . . . . \$95.00**

**MOTOROLA T41GGV 30-50mc 6/12 V,** 30 watt vibrator power supply fully narrow banded complete with accessories less crystals and antenna . . . . . **\$148**  
Add \$45.00 for tuning to desired frequency and new antenna

**MOTOROLA 30-50mc 6/12 V,** T51GGV vibrator power supply. Fully narrow banded (TX & RX) . . . . . **\$198**  
Above price include accessories less crystals and antenna (less accessories, deduct \$30.00)  
To tune unit to desired frequency including new antenna add \$45.00

**GE 2-Piece unit—6 volt or 12 volt 4ER6—4ET5, 30w 30-40, mc.—40-50 mc. Wide Band . . . . . \$48**  
Fully narrow band (TX+RX) . . . . . **\$68**  
Complete Accessories  
**4ER6—4ET6, 60w 30-40 mc.—40-50 mc. Wide Band . . . . . \$68**  
Fully Narrow Band . . . . . **\$88**  
Complete Accessories  
Add \$45.00 for tuning and crystals to desired frequency, including new antenna.

**RCA—CMCT 30 148-172 mc.** transistorized power supply fully narrow banded complete with accessories . . . . . **\$198**  
Add \$40.00 for crystals and tuning and new antenna.

**G.E. PACERS—EG43SA6 150-170 mc** Transistorized Power Supply 13-15 watts, 12 v Front Mount (Complete accessories, less crystals and antenna) . . . . . **\$108.00**

We Buy Late Model Equipment for Cash  
—Write: Wire or Phone!



**GREGORY ELECTRONICS CORPORATION**

249 RT. 46, Saddle Brook, N.J., 07662  
Phone: (201) 489-9000

CIRCLE NO. 112 ON READER SERVICE CARD

Silicon Control Rectifiers			
PRV	3A	7A	20A
50	.35	.50	.80
100	.50	.70	1.35
200	.75	1.05	1.90
300	1.25	1.60	2.45
400	1.50	2.10	2.85
500	1.75	2.80	3.50
600	2.00	3.00	
700	2.25	3.50	
1000		5.00	

**1.25 AMP (GLASS AMPS)**  
A controlled avalanche rectifier in which the rated PRV may be exceeded without the rectifier breaking down.

PRV	
100	.12
200	.15
400	.20
600	.25
800	.35
1000	.50

Top Hat & Epoxy 750 MA	
PRV	
100	.07
200	.09
400	.12
600	.20
800	.25
1000	.50
1200	.65
1400	.85
1600	1.00
1800	1.20

Terms: FOB Cambridge, Mass. Send check or Money Order. Include Postage, Average Wt. per package 1/2 lb. Allow for C.O.D. Minimum Order \$3.00



**POST OFFICE BOX 74B  
SOMERVILLE, MASS. 02143**

featuring transistors, rectifiers and components

SEND FOR OUR LATEST CATALOG

CIRCLE NO. 101 ON READER SERVICE CARD

## INTEGRATED CIRCUITS



SR Clocked Flip Flops . . . . . \$1.15  
SRT Flip Flops . . . . . \$1.15  
Expandable OR Gates . . . . . \$1.00  
JK Flip Flops . . . . . \$1.15  
Dual NAND Nor Gates . . . . . \$1.00  
TO-85 flat pack. Guaranteed to work. They come complete with schematic, elect. characteristic sheet & some typical applications.

Silicon Power Rectifiers				
PRV	3A	20A	40A	240A
100	.10	.40	1.00	5.00
200	.20	.60	1.50	7.50
400	.25	.80	2.00	15.00
600	.35	1.20	2.50	20.00
800	.45	1.50	3.00	
1000	.65		4.00	35.00



# BIG CATALOG

World's "BEST BUYS" in GOV'T. SURPLUS Electronic Equipment

## NAVY MARINE BAND WALKIE TALKIE

NAVY Marine Band WALKIE-TALKIE TRANSMITTER & RECEIVER—This equipment is crystal controlled and can be operated on any one channel in the frequency range of 2.3 to 4.5 MC. Voice (A3) communication only, output of trans. is 0.2 watts and satisfactory communication between units over average terrain should be able to be maintained up to approx. one (1) mile. With tubes: 1/1S5, 1/1R5, 2/1T4, 3/3S4. Voltages required 67.5 VDC 3 MA; 135 VDC 4 MA; 1.5 VDC 225 MA for Rec.—67.5 VDC 1.5 MA; 135 VDC 19 MA; 1.5 VDC 225 MA; & —6 VDC 30 MA for Trans. Unit comes in a waterproof plastic case with space for batt. or power supply. Telescoping antenna 8 ft. has special loading coil. Complete with tubes, antenna, 2 crystals FT-243 (no choice of freq.), headphones, carbon microphone, canvas cover, & manual. Size: 8 x 8 x 2½"; Wt.: 8 lbs. **\$9.95**



NAVY WALKIE-TALKIE DIRECTION FINDER MODEL "DAV"—Same as "MAB" except has a direction finding loop circuit for homing, and comes in a waterproof plywood case with web straps for carrying on back or chest. Also complete with tubes, 2 crystals (no choice of freq.) headphones, lip microphone, 8 ft. telescoping antenna, & manual. Size: 14 x 10 x 3"; Wt.: 11 lbs. **\$12.95**

VIBRATOR POWER SUPPLY—Designed for use with "MAB" & "DAV" described above. Operates from 6 VDC storage battery N-T-6, that fits on bottom of P. S. pack, 6 V 4 A (Can be operated from any 6 VDC 4 A source) supplies 1.5 VDC 3 A; —6 VDC .02 A; 67.5 VDC .005 A; 135 VDC .02 A. Size: 6½ x 3¾ x 1¾"; Wt.: 2 lbs. NEW **\$6.95**

N-T-6 PLASTIC STORAGE BATTERY for above Power Supply CRF-20221 A—Supplies 6 volts DC 4 Amp. Size: 3½ x 2½ x 2"; Wt.: 2 lbs. Dry charge battery.....**\$3.95**

## NEW CATALOG—

JUST OFF PRESS—SEND 25¢ (stamps or coin) and receive 50¢ CREDIT on your order! Address Dept. EW • Prices F.O.B. Lima, O. • 25% Deposit on C.O.D.'s

## FAIR RADIO SALES

1016 E. EUREKA • Box 1105 • LIMA, OHIO • 45802

## UNUSUAL BARGAINS

... MANY U.S. GOV'T SURPLUS

### GIANT WEATHER BALLOONS



"Balls of fun" for kids, traffic stoppers for stores, terrific for amateur meteorologists. Create a neighborhood sensation. Great backyard fun. Exciting beach attraction. Made of heavy duty neoprene. Inflate with vacuum cleaner or auto air hose; or locally available helium for high rise.

# 60, 568AK (8' diam) \$2 Ppd.  
# 60, 632AK (16' diam) \$7 Ppd.

### NEW, LOW-COST GEM TUMBLER



Become a rockhound! Fascinating hobby... loads of fun... inexpensive, easy. Make jewelry of all kinds—decorative bookends, table tops, etc. Simply tumble-finish readily available gemstones... then polish to high luster... brings out beautiful colors. Its 7-lb. capacity tumbler w/continuous duty motor compares to units selling for many times its price. Full instructions.

Stock No. 70,874AK.....\$10.75 Ppd.  
6-LB. ROCK ASSORTMENT (10 types).....\$9.00 Ppd.  
Stock No. 70,868AK.....\$9.00 Ppd.

### NEW SURPLUS NI-CD BATTERIES



Save more than 50%! Long life—accept 100 charge and discharge cycles. 1.25 Volts per cell—750 milliamper hours capacity. Excellent charge retention. Hermetically sealed. Indefinite storage life. Multiple cells welded in series—easily cut. Combine to form batts. 7/8" dia. x 1 1/2" high. Spec. price for 100 up. Low-cost charger separate.

Order #	Cells	DC Volt.	Price Ppd.
40,986AK	1	1.25	\$ 1.50
40,987AK	2	2.50	2.75
60,633AK	3	3.75	3.60
60,634AK	4	4.99	4.80
70,812AK	Trickle Charger (1-10 cells)		10.95

Edmund Scientific Co., Barrington, N.J. 08007

## MAIL COUPON for FREE CATALOG

SEND FOR FREE CATALOG "AK"

Completely new 1967 edition. New items, categories, illustrations. 148 ea.—to-read pages packed with nearly 4000 unusual items. Dozens of electrical and electronic parts, accessories. Enormous selection of Astronomical Telescopes, Microscopes, Binoculars, Magnifiers, Mirrors, Lenses, Prisms. Many var surplus items for hobbyist, etc. Perimeters, workshop, factory. Write for catalog "AK." Please include your Zip Code.



NAME \_\_\_\_\_  
ADDRESS \_\_\_\_\_  
CITY \_\_\_\_\_ STATE \_\_\_\_\_ ZIP \_\_\_\_\_

CIRCLE NO. 119 ON READER SERVICE CARD

## AUTHORS' SERVICES

**AUTHORS!** Learn how to have your book published, promoted, distributed. FREE booklet "ZD," Vantage, 120 West 31 St., New York 10001.

**POEMS WANTED** for new song hits and recordings by America's most popular studio. Tin Pan Alley, 1650-ZD Broadway, New York 10019.

## HYPNOTISM

**FREE Hypnotism, Self-Hypnosis, Sleep Learning.** Catalog! Drawer H400, Ruidoso, N.M. 88345.

**FREE TRIAL!!** Sensational self-hypnosis record kit improves memory, concentration, personality. Results guaranteed! Forum, 333-AA8, Michigan, Chicago 60601.

**HYPNOTIZE FEMALES!**—Unnoticed! Instantly! Nerves! Exciting! Send \$2.25. Research Enterprises, 29-SN21 Samoset, Woburn, Mass. 01801.

**FEMALE HYPNOTISM!** Easily! Instantly! Secret Nerve Centers! \$2.20. Brugenheimer Publishers. Box 158-E30, Lexington, Mass.

## PHOTOGRAPHY—FILM, EQUIPMENT, SERVICES

**MEDICAL FILM**—Adults only—"Childbirth" one reel, 8mm \$7.50; 16mm \$14.95. International W. Greenvale, Long Island, New York 11548.

**SCIENCE Bargains**—Request Free Giant Catalog "CJ"—148 pages—Astronomical Telescopes, Microscope, Lenses, Binoculars, Kits, Parts, War Surplus bargains. Edmund Scientific Co., Barrington, New Jersey 08007.

## PLANS AND KITS

**TEACHERS**—Students build visual aid. Four tube regen. RCVR.; four individual etched printed circuits, 3"x5" ea., connectors, plans \$3.00. Plans 50¢. Teacher, 1751 Greek Dr., San Jose, Calif. 95125.



which one should you buy ?

This year, play it smart. Before you make your next photographic equipment purchase, make sure you're getting the most for your money. Shop before you buy, confidently, with the up-to-the-minute 1967 PHOTOGRAPHY DIRECTORY & BUYING GUIDE.

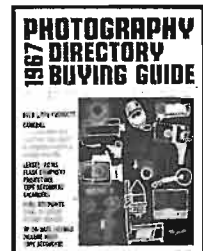

All the guesswork is out! From still cameras to slide projectors, super-8 to video tape recorders... this encyclopedic volume puts every essential buying fact and figure right at your fingertips. With complete point-by-point information on manufacturer, model number, special characteristics and price. Hundreds of photos. Every vital statistic you need to compare all the latest equipment—in virtually every category—and select the best in your price range!

Over 5,000 photographic items in all! Plus a Special Feature! "BUYPOINTS"—an exclusive "what-to-look-for, how-to-buy" guide to movie and still cameras, slide projectors, tape recorders.

This 160-page "shop-at-home" directory has been carefully compiled by the editors of Popular Photography. And that means authoritative, precise information you can bank on. All year long!

GET THE HANDSOME LEATHERFLEX-BOUND EDITION for just \$3 POSTPAID! The 1967 PHOTOGRAPHY DIRECTORY & BUYING GUIDE is also available in a splendid deluxe edition. Rugged leatherflex cover provides lasting protection yet is softly textured and gold embossed for the look of elegance. A collector's item—a superb addition to your permanent reference library. And it's yours, for just \$3 postpaid, when you check the appropriate box on the order form.

Use the coupon below to order your copy of the 1967 PHOTOGRAPHY DIRECTORY & BUYING GUIDE today! Only \$1.25

ZIFF-DAVIS SERVICE DIVISION • DEPT. PD 595 Broadway • New York, N.Y. 10012

Please send me a copy of the 1967 PHOTOGRAPHY DIRECTORY & BUYING GUIDE as checked below:

\$1.25 enclosed, plus 15¢ for shipping and handling. Send me the regular edition. (\$1.75 for orders outside the U.S.A.)

\$3.00 enclosed. Send me the Deluxe Leatherflex-bound edition, postpaid. (\$3.75 for orders outside the U.S.A.) Allow three additional weeks for delivery.

name \_\_\_\_\_ please print \_\_\_\_\_ EW-87  
address \_\_\_\_\_  
city \_\_\_\_\_  
state \_\_\_\_\_ zip \_\_\_\_\_  
**PAYMENT MUST BE ENCLOSED WITH ORDER**

## RECTIFIERS, TRANSISTORS & COMPONENTS

6 tube Amplifier, New 4 lbs. ....2/\$1.98  
 1/4 Watt Resistors, asstd. ....50/1.00  
 1/2 Watt Resistors, asstd. ....60/1.00  
 2N4138 Sil. Chopper To-46 NPN .....1.50  
 Precision Resistors, asstd. ....50/1.00  
 Pots, 2-4 Watt, asstd. ....15/1.00  
 2N1724 Sil. Pow. 50 W. 80 V. Stud. ....1.50  
 2N1047B Sil. Pow. 80V. To-57 .....60  
 Tantalum Capacitors, asstd. ....10/1.00  
 2N1722 Sil. Pow. 50W. 80V. To-53 .....1.45  
 2N2944 Sil. Chopper To-46 .....1.00  
 50W. Zeners 10 to 19 Volts .....1.00  
 Thermistor bead, or 1200 ohm. ....2/1.00  
 2N1021, Ger. Power, 7amp, 100V., To -3 .....60  
 2N456A, 7A. 40V. Ger. Power To -3 .....45  
 2N1718, Sil. Power, 10W, 60V., Heatsink .....3/1.00  
 70 amp Stud. 50PIV—\$2.50; 100PV .....\$3.50

**SILICON CONTROLLED RECTIFIERS**  
 AMPS. 300PRV. 400PRV. 500PRV.  
 7A. 1.50 2.05 2.75  
 16A. 2.15 2.65 3.25  
 Pots, 1W, 100K, or 1/2 W. 500K. ....5/1.00  
 Surprise Kit, 10 lbs. components .....2.50  
 Epoxy Hi-Vol diode, 200ma, 3000PIV .....98  
 Computer Board, TO-3 Power, Heat Sink .....1.00  
 I.C., TO-5, untested .....5/100  
 I.C., Dual-in-line, untested .....10/1.00  
 2N389, 85W 60 V. TO53 .....79  
 2N3707-11 Asstd. Plastic Silicon Xistors .....20/1.00  
 2N3704-3706, Asstd. Plastic Sil. Xistors .....10/1.00  
 2N2151, Sil. Power Xistar .....65  
 2N1009 Ger. Min. Xistar untested .....30/1.00  
 3N35 Tetrode, NPN, untested .....5/1.00  
 Ger. Diodes, Asstd. ....15/100  
 2N458A, 7A. 80V. Ger. Power, TO -3 .....55  
 Sil. Diodes, Switching, Signal, Asst. ....15/1.00  
 2N118, Silicon, NPN, untested .....10/1.00  
 2N1149, Silicon, NPN, untested .....20/1.00  
 2N1300, Unst. PNP & NPN, 1/4" leads .....25/1.00  
 2N1714, Silicon Power 10W, 60V. ....4/1.00  
 Computer Boards, Parts Free, per transistor .....05  
 Germanium Power, 2N457A, 7A; 60V .....50  
 Silicon Power 40 W, 2N1047, TO-57 .....2/1.00  
 Tophats 750 ma., 200PIV-8¢, 400, 12¢ 600 PIV .....18  
 IN34A .....100/2.98  
 Varicaps, 27, 47, or 100 pf. ....1.25  
 2N1038, Germanium 20 W. 40 V .....4/1.00  
 With any \$10.00 Order any \$1.00 item Free. On \$25.00 order any (3) \$1.00 items Free. Catalog.

Minimum order \$3.00 plus postage, C.O.D.'s 25%

## ELECTRONIC COMPONENTS

Post Office Box 2902 Baton Rouge, Louisiana 70821

CIRCLE NO. 116 ON READER SERVICE CARD

A SELECTION OF

## ANNUALS STILL AVAILABLE

FROM THE WORLD'S LARGEST PUBLISHER OF SPECIAL INTEREST MAGAZINES



### PHOTOGRAPHY ANNUAL

A selection of the World's finest photographs compiled by the editors of Popular Photography. 212 pages—24 in full color.

1967 — \$1.50 .....#38  
 1966 — \$1.25 .....#1  
 1964 — \$1.25 .....#3



### POLAROID LAND PHOTOGRAPHY

Complete guide and only comprehensive and up-to-date handbook on Polaroid Land Photography.

1966 — \$1.25 .....#24  
 1963 — \$1.00 .....#25

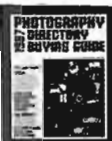

### PHOTOGRAPHY DIRECTORY

World's most complete photographic buying guide.

1967 — \$1.25 .....#41  
 1966 — \$1.25 .....#22



### STEREO/Hi Fi DIRECTORY

Complete buyers guide for virtually every Hi Fi component manufactured.

1967 — \$1.25 .....#45  
 1966 — \$1.25 .....#29

Order by number from Ziff-Davis Service Division, 595 Broadway • New York, N.Y. 10012 Enclose an additional 15¢ per copy for shipping and handling (50¢ for orders outside U.S.A.)

## BOOKS

UNUSUAL Books — catalogue free — Starlight Press, 170-05, Baisley Boulevard, Jamaica, New York 11434.

## EMPLOYMENT INFORMATION

FOREIGN and USA job opportunities available now. Construction, all trades. Earnings to \$2,000.00 monthly. Paid overtime, travel, bonuses. Write: Universal Employment, Woodbridge, Connecticut 06525.

FOREIGN EMPLOYMENT. Construction, other work projects. Good paying overseas jobs with extras, travel expenses. Write only: Foreign Service Bureau, Dept. D, Bradenton Beach, Florida 33510.

## BUSINESS OPPORTUNITIES

INVESTIGATE ACCIDENTS: Earn up to \$1,000 and more a month in your own business. Work spare time with average earnings of \$5 to \$8 per hour. No selling. Send for FREE booklet. No obligation. No salesman will call. Write: Universal Schools, CZ-8, 6801 Hillcrest, Dallas, Texas 75205.

FREE BOOK "990 Successful, Little-Known Businesses." Work home! Plymouth-145H, Brooklyn, New York 11218.

I MADE \$40,000.00 YEAR by mailorder! Helped others make money! Start with \$10.00—Free proof. Torrey, Box 318-N, Ypsilanti, Michigan 48197.

FREE CATALOGS. Repair air conditioning, refrigeration. Tools, supplies, full instructions. Doolin, 2016 Canton, Dallas, Texas 75201.

HOW and Where to get Capital. Start or expand any electronics or photography business. Write: Counselor—48, Harlingen, Texas 78550.

## STAMPS

FREE Wonderful New United States Catalog! Postage and Airmails Complete. 786 Illustrations. Special offers, Bargains Galore—Everything! Send Today. H. E. Harris, Dept. FC-1, Boston, Mass. 02117.

## MISCELLANEOUS

WINEMAKERS: Free illustrated catalog of yeasts, equipment. Semplex, Box 7208, Minneapolis, Minn. 55412.

EMPLOYMENT Resumes. Get a better job & earn more! Send only \$2.00 for expert, complete Resume Writing Instructions. J. Ross, 80-34 Kent St., Jamaica, N.Y. 11432 Dept. EW.

SPARE TIME OPPORTUNITY—MONEY. WE PAY \$10 hr. for NOTHING but your opinions, written from home about our clients' products and publications, sent you free. Nothing to buy, sell, canvass, or learn. NO SKILL, NO GIMMICKS. Just honesty. Details from RESEARCH, ZD-3, Box 669, Mineola, N.Y. 11501.

TEN Winemaking Recipes and Winemaking Supplies catalog. 10¢. Country Winemaker, Box 243EGA, Lexington, Massachusetts 02173.

**MICRO** SINCE 1957  
 Not connected with any other Mail Order Tube Co.  
**LARGE SELECT STOCK**  
**DEPENDABLE FAST SERVICE**  
**35¢** ea. in lots of 100  
**37¢** per tube  
 WE HAVE PICTURE TUBES  
 Send For FREE Tube List & Special Purpose Tubes  
**MICRO Electron Tube Co.**  
 110 MARTIN ST., PATERSON, N. J.  
 ALL tubes sent postage pd. Send 35¢ handling chg. on orders under \$5. Send 25% on C.O.D.'s. Send approx. postage on Canadian & foreign orders.

August, 1967

# MOVIN'SALE

3 BULGING WAREHOUSES

We will have 2 Places to serve you soon

**DOUBLE BONUS**

**\$25**

PLUS CHOOSE ANY \$1.00 ITEM FREE  
 WORTH OF TRANSISTORS RECTIFIERS RESISTORS CONDENSERS DIODES & ETC  
 Add 25¢ for handling

**BOTH FREE WITH ANY \$10 ORDER**

1 AMP  400 mc  
 800 PIV TOP HAT  NPN SILICON  
 RECTIFIERS **5 for \$1**  
 5 for \$1  
 Watts V<sub>cb</sub> H<sub>fe</sub> | ma  
 .5 | 30 | 20 -300 | 150

## FACTORY TESTED \$1 SEMI-KON-DUCTORS

- 2-85 WATT 2N424 PLANAR, silicon, TO-53 npn .
- DUAL TRANSISTORS  PNP (2N2807)  NPN 2N2060
- 3-40W NPN SILICON MESA 2N1648 transistor . \$1
- 4 2N170 TRANSISTORS, by GE, npn for gen'l rf . \$1
- 10 3 Amp RECT's, studs, silicon, to 800 V no test \$1
- 4-2N255 POWER TRANSISTOR EQUALS. . \$1
- 10 PNP SWITCHING TRANSISTORS, 2N404, no test. \$1
- 2N3088 "N" Channel FET's Very High Input Z \$1
- 5 2N107 TRANS'RS, by GE, npn, pop. audio pak \$1
- 3-2N1613 3W NPN SIL, 120 mc. by "Rheem" \$1
- 3-45AMP POWER RECTIFIERS, stud, silicon . . \$1
- 10 PNP SWITCHING TRANSISTORS, no test, TO5 \$1
- 4 2N43 OUTPUT TRANSISTORS, by GE, npn, TO5 \$1
- 1-IGNITION SWITCHING TRANSISTORS, 10 AMP \$1
- 25 GERMANIUM & SILICON DIODES, no test . . \$1
- 25 TOP HAT RECTIFIERS, silicon, 750ma, no test \$1
- 2-1000 MC-TRANSISTOR 2N918 NPN SILICON \$1
- 4 2N333 NPN SILICON transistors, Transistron. \$1
- 4 BIDIRECTIONAL TRANSISTORS, 2N1641 . . . \$1
- 10 NPN SWITCHING TRANSISTORS, 2N338 no test \$1
- 15 PNP TRANSISTORS, CK722, 2N35, 107, no test \$1
- 15 NPN TRANSISTORS, 2N35, 170, 440, no test . \$1
- 30 TRANSISTORS, rf, lf, audio osc-ifs, TO5 no test \$1
- 10 FAMOUS CK722 TRANSISTORS, . . npn no test . \$1

**1-Amp TOP HAT AND EPOXIES**

PIV	Sale	PIV	Sale	PIV	Sale
50	5¢	600	19¢	1400	69¢
100	7¢	800	25¢	1600	89¢
200	9¢	1000	45¢	1800	99¢
400	11¢	1200	59¢	2000	1.50

## WORLD'S MOST POPULAR \$1 PARTS PAKS

- 30 "YELLOW" MYLAR CONDENSERS, asstd val \$1
- 60 CERAMIC CONDENSERS, discs, npn's, to .05 \$1
- 60 TUBULAR CONDENSERS, to .5mf, to 1Kv, asst \$1
- 40 DISC CONDENSERS, 27mmf to .05mf to 1KV \$1
- 60 TUBE SOCKETS, receptacles, plugs, audio, etc. \$1
- 30 POWER RESISTORS, 5 to 50W, to 24 Kohms. \$1
- 65 HALF WATTERS, asst incl: A.B., 5% too! . \$1
- 60 HI-Q RESISTORS, 1/2, 1, 2W, 1% & 5% values \$1
- 10 VOLUME CONTROLS, to 1 meg, switch too! \$1
- 10 ELECTROLYTICS, to 500mf, asst FP & tubulars \$1
- 50 RADIO & TV KNOBS, asstd. colors & styles \$1
- 4 TRANSISTOR TRANSFORMERS, asst, worth \$25 \$1
- 40 PRECISION RESISTORS, 1/2, 1, 2W, 1% values \$1
- 40 CORNING "LOW NOISE" resistors; asst. . \$1
- 10 PHONO PLUG & JACK SETS, tuners, amps . \$1
- 50 TERMINAL STRIPS, 1 to 8 solder lug types . \$1

**'GLASS AMP' ★** Handles 2 Amps PIV Sale  
 ONE AMP A controlled avalanche rectifier 100 7¢  
 SILICON the rated 200 9¢  
 RECTIFIERS PRV may be exceeded without the rectifier breaking down. 400 13¢  
 600 19¢  
 800 29¢  
 1000 45¢

MONEY BACK GUARANTEE

10¢ FOR OUR "FALL" BARGAIN CATALOG ON:  
 Semiconductors  Poly Paks  Parts

**POLY PAKS**  
 TERMS: send check, money order, include postage—avg. wt. per pkg 1 lb. Rated, net 30 days. CODs 25%  
 P.O. BOX 942W  
 SO. LYNNFIELD, MASS. 01940  
 "PAK-KING" of the World

CIRCLE NO. 103 ON READER SERVICE CARD





Dreaming about winning first prize in a photo contest?

Well, whether you're a perplexed beginner, a serious hobbyist—or someone who just likes to take pictures—everything you need to know about getting the best out of your camera is now clearly defined in one concise, easy-to-understand guidebook.

**The all-new 1967 INVITATION TO PHOTOGRAPHY!**

Produced by the editors of POPULAR PHOTOGRAPHY, INVITATION is a unique 124 page "course" in better picture taking.

**Including:**

- a primer of photographic terms
- color wizardry
- choosing the equipment you really need
- girls and glamor
- suiting the film to the occasion
- creative composition
- using the right light
- which lens for you
- starring the kids
- darkroom procedure simplified
- not-so-simple-pictures from simple cameras
- eliminating the hocus-focus from portrait, action and night shots.

**Plus an extra BONUS—**

Lights, camera, action! A complete 28 page section on movie making... movie cameras... creative and technical filming procedures.

Over 20 complete sections in all! Each written by an expert to help you progress quickly, easily, *confidently*. So whether you're aiming at professional blue ribbons, or professional-quality photos for your family album—take the first important step now. By ordering *your* INVITATION TO PHOTOGRAPHY! **Only \$1.25**

INVITATION TO PHOTOGRAPHY is also available in a handsome deluxe edition. Rugged Leatherflex cover provides lasting protection yet is softly textured and gold-embossed for the look of elegance. A collector's item—a superb addition to your permanent photo reference library. And it's yours, for just \$3 postpaid, when you check the appropriate box on the order form.

ZIFF-DAVIS SERVICE DIVISION • DEPT. IP  
595 BROADWAY • NEW YORK, N. Y. 10012

YES! Please send my copy of the 1967 INVITATION TO PHOTOGRAPHY as checked below:

- \$1.25 enclosed, plus 15¢ for shipping and handling. Send me the regular edition. (\$1.75 for orders outside the U.S.A.)
- \$3.00 enclosed. Send me the Deluxe Leatherflex-bound edition, postpaid. (\$3.75 for orders outside the U.S.A.) Allow three additional weeks for delivery.

Print Name \_\_\_\_\_ EW-87

Address \_\_\_\_\_

City \_\_\_\_\_

State \_\_\_\_\_ Zip Code \_\_\_\_\_

**PAYMENT MUST BE ENCLOSED WITH ORDER**

**ELECTRONICS WORLD AUGUST 1967  
ADVERTISERS INDEX**

READER SERVICE NO.	ADVERTISER	PAGE NO.	READER SERVICE NO.	ADVERTISER	PAGE NO.
	Allied Radio .....	81, 82	110	Hickok Electrical Instrument Company, The .....	67
	American Institute of Engineering & Technology .....	65	109	Lampkin Laboratories, Inc. ....	58
125	Antenna Specialists Co., The .....	4	108	Mallory & Co., Inc., P.R. ....	65
	Arcturus Electronics Co. ....	93	199	Methods Research Corp. ....	69
	Belden Manufacturing Company ....	2		Micro Electron Tube Co. ....	97
	Capitol Radio Engineering Institute, The .....	60, 61, 62, 63	106	Microflame, Inc. ....	78
123	Cleveland Institute of Electronics ....	7	105	Milwaukee School of Engineering	69
122	Cleveland Institute of Electronics	18, 19, 20, 21	104	Music Associated .....	65
121	Crown International .....	69		National Radio Institute ....	8, 9, 10, 11
120	Delta Products, Inc. ....	55	103	Poly Paks .....	97
	EICO Electronic Instrument Co., Inc. ....	3rd Cover		RCA Electronic Components and Devices .....	4th Cover
94	Editors and Engineers, Ltd. ....	66		RCA Institutes, Inc. ....	70, 71, 72, 73
119	Edmund Scientific Co. ....	96		RCA Sales Corp. ....	22
118	Electro-Voice, Inc. ....	12	102	Radar Devices Manufacturing Corp.	5
116	Electronic Components .....	97	101	Solid State Sales .....	95
	Fair Radio Sales .....	96	100	Sonotone Corporation .....	14
93	Finney Company, The .....	15	99	Sony/Superscope, Inc. ....	6
	G & G Radio Supply Company .....	94	98	Surplus Center .....	94
114	Goodheart Co., Inc., R.E. ....	93	198	Texas Crystals .....	66
	Greenlee Tool Co., Division of Greenlee Bros. & Co.	65		Valparaiso Technical Institute .....	58
112	Gregory Electronics Corporation ....	95	96	Weller Electric Corp. ....	91
111	Heath Company .....	2nd Cover, 1	197	Whale Electronics, Inc. ....	13
				Zenith .....	17
			95	Zenith .....	79

CLASSIFIED ADVERTISING 93, 94, 95, 96, 97



### Introducing EICO's New "Cortina Series"!

Today's electro-technology makes possible near-perfect stereo at moderate manufacturing cost; that's the design concept behind the new EICO "Cortina" all solid-state stereo components. All are 100% professional, conveniently compact (3 1/8"H, 12"W, 8"D), in an esthetically striking "low silhouette." Yes, you can pay more for high quality stereo. But now there's no need to. The refinements will be marginal and probably inaudible. Each is \$89.95 kit, \$129.95 wired.

**Model 3070 All-Silicon Solid-State 70-Watt Stereo**

**Amplifier:** Distortionless, natural sound with unrestricted bass and perfect transient response (no inter-stage or output transformers); complete input, filter and control facilities; failure-proof rugged all-silicon transistor circuitry.

**Model 3200 Solid-State FM/MPX Automatic Stereo Tuner:** Driftless, noiseless performance; 2.4μV for 30db quieting; RF, IF, MX are pre-wired and pre-tuned on printed circuit boards — you wire only non-critical power supply.

# 7 New Ways to make Electronics more Fun!

Save up to 50% with EICO Kits and Wired Equipment.



You hear all the action-packed capitals of the world with the NEW EICO 711 "Space Ranger" 4-Band Short Wave Communications Receiver — plus ham operators, ship-to-shore, aircraft, Coast Guard, and the full AM band. 550KC to 30MC in four bands. Selective, sensitive superhet, modern printed circuit board construction. Easy, fast pinpoint tuning; illuminated slide-rule dials, logging scale; "S" meter, electrical bandspread tuning, variable BFO for CW and SSB reception, automatic noise limiter, 4" speaker. Headphone jack. Kit \$49.95. Wired \$69.95.



More "ham" for your dollar than ever — with the one and only SSB/AM/CW 3-Band Transceiver Kit, new Model 753 — "the best ham transceiver buy for 1966" — Radio TV Experimenter Magazine. 200 watts PEP on 80, 40 and 20 meters. Receiver offset tuning, built-in VOX, high level dynamic ALC, silicon solid-state VFO. Unequaled performance, features and appearance. Sensionally priced at \$189.95 kit, \$299.95 wired.



### NEW EICO 888 Solid-State Engine Analyzer

Now you can tune-up, troubleshoot and test your own car or boat.

Keep your car or boat engine in tip-top shape with this completely portable, self-contained, self-powered universal engine analyzer. Completely tests your total ignition/electrical system. The first time you use it — just to tune for peak performance — it'll have paid for itself. (No tune-up charges, better gas consumption, longer wear) 7 instruments in one, the EICO 888 does all these for 6V and 12V systems; 4, 6 & 8 cylinder engines.

The EICO 888 comes complete with a comprehensive Tune-up and Trouble-shooting Manual including RPM and Dwell angle for over 40 models of American and Foreign cars. The Model 888 is an outstanding value at \$44.95 kit, \$59.95 wired.



New EICOCRAFT® easy-to-build solid-state electronic TruKits:® great for beginners and sophisticates alike. As professional as the standard EICO line — only the complexity is reduced to make kit-building faster, easier, lower cost. Features: pre-drilled copper-plated etched printed circuit boards; finest parts; step-by-step instructions; no technical experience needed — just soldering iron and pliers. Choose from: Fire Alarm; Intercom; Burglar Alarm; Light Flasher; "Mystifier"; Siren; Code Oscillator; Metronome; Tremolo; Audio Power Amplifier; AC Power Supply. From \$2.50 per Kit.



New EICO "Nova-23" (Model 7923) all solid-state 23-channel 5 watt CB Transceiver featuring a host of CB advances — plus exclusive engineering innovations.

**EXCLUSIVE** dual-crystal lattice filter for advanced razor-sharp selectivity of reception. **EXCLUSIVE** highly efficient up-converter frequency synthesizer provides advanced stability and freedom from trouble in all 23 crystal-controlled transmit-receive channels. All crystals supplied. **EXCLUSIVE** use of precision series-mode fundamental crystals for superior transmit and receive stability. **Wired only, \$189.95**



**Model 460 Wideband Direct-Coupled 5" Oscilloscope.** DC-4.5mc for color and B&W TV service and lab use. Push-pull DC vertical amp., bal. or unbal. input. Automatic sync limiter and amp. \$99.95 kit, \$139.50 wired.

### FREE 1967 CATALOG

EICO Electronic Instrument Co., Inc. EW-8  
131-01 39th Ave., Flushing, N. Y. 11352

Send me FREE catalog describing the full EICO line of 200 best buys, and name of nearest dealer. I'm interested in:

- test equipment                       ham radio  
 stereo/hi-fi                               Citizens Band radio  
 automotive electronics

Name \_\_\_\_\_  
Address \_\_\_\_\_  
City \_\_\_\_\_  
State \_\_\_\_\_ Zip \_\_\_\_\_



**Model 232 Peak-to-Peak VTVM.** A must for color or B&W TV and industrial use. 7 non-skip ranges on all 4 functions. With exclusive Uni-Probe.® \$29.95 kit, \$49.95 wired.



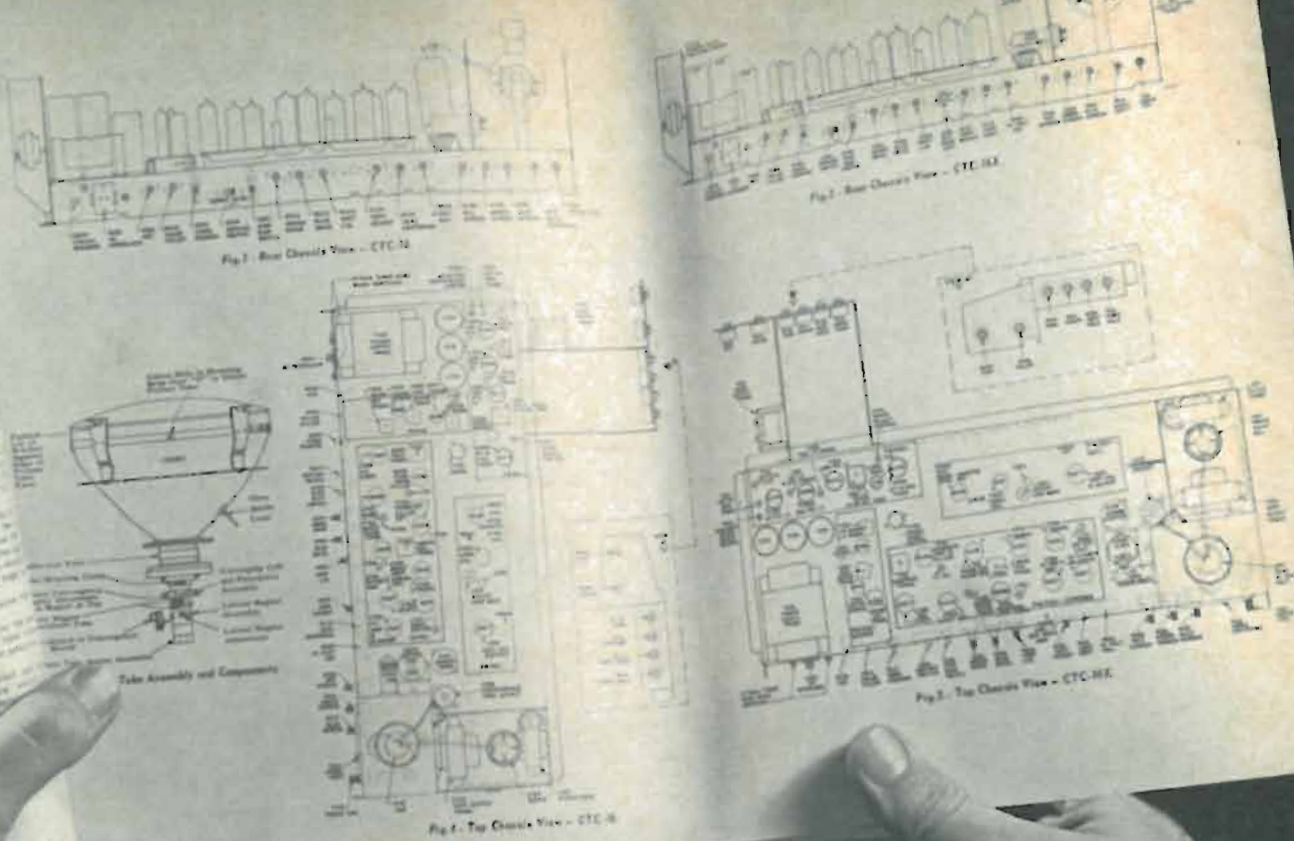

# You need this guide for RCA Color Home Service Calls!

RCA'S NEW FIELD SERVICE GUIDE, ERT-200 helps you make all adjustments on all RCA color sets from 1955 to 1966 that can be performed in the home... including step-by-step procedure for replacing a color picture tube.

Three part index lets you look up the set you are working on by model number, name or chassis number. You'll find the ERT-200 Field Service Guide indispensable. There's nothing like it on house calls for RCA color sets.

**WHAT THIS GUIDE CONTAINS:**

- Schematics on all RCA color sets from 1955 to 1966
- Field service adjustments (AGC, linearity, centering, etc.)
- Convergence, purity and black and white setup adjustments
- Parts lists
- Wave forms keyed to test points for majority of chassis
- Top and rear chassis views
- Photos of typical receivers
- Index of models from CTC2 through CTC20
- Separate section on tuner schematics
- Separate section on remote tuner schematics

## FIELD-SERVICE GUIDE

**RCA COLOR-TV RECEIVERS**

1955-1966

**FEATURES**

- Field Service Adjustments - CTC-12 through CTC-20A
- Top and Rear Chassis Views
- Schematic Diagrams
- Voltage Waveforms Keyed To Test Points
- Separate Section on Tuner Schematics
- Parts Lists
- Comprehensive Index of Model Number, Model Name, and Chassis Number

See your RCA Tube Distributor today and arrange to get your copy.

RCA Electronic Components and Devices, Harrison, N.J. 07029



The Most Trusted Name in Electronics